



---

**Programme Area:** Bioenergy

**Project:** Biomass to Power with CCS

**Title:** WP1 Detailed Final Report

---

**Abstract:**

This report, the first deliverable from the project, is a landscape overview of current biomass based power generation and CCS technologies. It also reviews current global demonstration activities. The consortium has assessed the various combinations of biomass power with CCS technologies, before recommending a shortlist of eight technologies for further detailed study in the rest of the project. The report includes an explanation of the consortium's high-level thoughts, structuring and prioritisation behind their recommendation to take 8 technologies forward.

**Context:**

The Biomass to Power with CCS Phase 1 project consisted of four work packages: WP1: Landscape review of current developments; WP2: High Level Engineering Study (down-selecting from 24 to 8 Biomass to Power with CCS technologies); WP3: Parameterised Sub-System Models development; and WP4: Technology benchmarking and recommendation report. Reports generally follow this coding. We would suggest that you do not read any of the earlier deliverables in isolation as some assumptions in the reports were shown to be invalid. We would recommend that you read the project executive summaries as they provide a good summary of the overall conclusions. This work demonstrated the potential value of Biomass to Power with CCS technologies as a family, but it was clear at the time of the project, that the individual technologies were insufficiently mature to be able to 'pick a winner', due to the uncertainties around cost and performance associated with lower Technology Readiness Levels (TRLs).

---

**Disclaimer:**

The Energy Technologies Institute is making this document available to use under the Energy Technologies Institute Open Licence for Materials. Please refer to the Energy Technologies Institute website for the terms and conditions of this licence. The Information is licensed 'as is' and the Energy Technologies Institute excludes all representations, warranties, obligations and liabilities in relation to the Information to the maximum extent permitted by law. The Energy Technologies Institute is not liable for any errors or omissions in the Information and shall not be liable for any loss, injury or damage of any kind caused by its use. This exclusion of liability includes, but is not limited to, any direct, indirect, special, incidental, consequential, punitive, or exemplary damages in each case such as loss of revenue, data, anticipated profits, and lost business. The Energy Technologies Institute does not guarantee the continued supply of the Information. Notwithstanding any statement to the contrary contained on the face of this document, the Energy Technologies Institute confirms that the authors of the document have consented to its publication by the Energy Technologies Institute.

# Biomass to Power with CCS Project

TESBiC: Techno-Economic Study of Biomass to power with CCS

PM01.D1.3

## **WP1 Detailed Final Report**

Prepared for the Energy Technologies Institute LLP

06/07/2011

V0.3



<b>Title</b>	Technologies Assessment and Recommendations
<b>Client</b>	Energy Technologies Institute LLP (ETI)
<b>Reference</b>	BwCCS PM01 D1.3
<b>Date</b>	01 July 2011
<b>Version</b>	0.2
<b>Authors</b>	The TESBIC consortium:



cmcl innovations



Doosan Babcock

Doosan Babcock



Drax



EDF



E4tech



Imperial College London



University of Cambridge



University of Leeds

## Distribution

This report has been prepared by the TESBIC consortium under contract to the ETI.

The contents of this report may not be reproduced in whole or in part, nor distributed to any third parties without the specific prior written consent of the ETI.

The members of the TESBIC consortium accept no liability for any loss or damage arising from any interpretation or use of the information contained in this report, or reliance on any views expressed therein.

## Contents

<b>0</b>	<b>Executive Summary .....</b>	<b>6</b>
<b>1</b>	<b>Introduction to biomass power with CCS.....</b>	<b>16</b>
1.1	What is biomass CCS? .....	16
1.2	Context.....	17
1.3	Objectives and structure of this report .....	18
1.4	Technology Readiness Levels.....	19
1.5	Scope for the study .....	20
<b>2</b>	<b>Review of component technologies.....</b>	<b>22</b>
2.1	Information gathered .....	22
2.2	Biomass conversion technologies.....	23
2.2.1	Pulverised coal combustion, with direct co-firing or conversion to 100% biomass .....	24
2.2.2	IGCC coal gasification, with direct co-firing or conversion to 100% biomass.....	34
2.2.3	Dedicated biomass combustion .....	41
2.2.4	Dedicated biomass gasification .....	46
2.3	Carbon capture technologies.....	64
2.3.1	Post-combustion capture: Solvent scrubbing.....	65
2.3.2	Post-combustion capture: Low temperature solid sorbents.....	77
2.3.3	Post-combustion capture: Ionic liquids .....	82
2.3.4	Post-combustion capture: Enzymes .....	86
2.3.5	Post-combustion capture: Membrane separation of CO <sub>2</sub> from flue gas .....	90
2.3.6	Post-combustion capture: High-temperature solid sorbents.....	97
2.3.7	Oxy-combustion: Oxy-fuel boiler with cryogenic O <sub>2</sub> separation from air .....	108
2.3.8	Oxy-combustion: Ion-exchange membrane separation of O <sub>2</sub> from air .....	118
2.3.9	Oxy-combustion: Chemical-looping-combustion using solid oxygen carriers.....	126
2.3.10	Pre-combustion: IGCC with solvent absorption .....	137
2.3.11	Pre-combustion: Membrane separation of H <sub>2</sub> from syngas.....	147
2.3.12	Pre-combustion: Sorbent enhanced reforming using carbonate looping .....	151
2.4	Feedstocks and pre-processing considerations .....	161
2.4.1	Feedstock availability .....	161
2.4.2	Biomass sustainability and international trade .....	162
2.4.3	Physical and fuel properties .....	163
2.4.4	Ash behaviour.....	166
2.4.5	Pre-processing technologies.....	172
2.4.6	Impact of feedstock on biomass conversion technologies.....	174

<b>3</b>	<b>Technology combinations .....</b>	<b>178</b>
3.1	Combinations and groupings of technologies .....	178
3.2	Global demonstration projects .....	180
<b>4</b>	<b>Assessment criteria.....</b>	<b>183</b>
4.1	Description of the assessment criteria chosen .....	184
<b>5</b>	<b>Assessment of technology combinations.....</b>	<b>187</b>
<b>6</b>	<b>Recommendations.....</b>	<b>202</b>
6.1	Combinations rejected.....	202
6.2	Combinations recommended for progression.....	203
6.3	Quantitative supporting data .....	205
6.4	Suitability for small-scale power applications .....	215
6.5	Summary matrix.....	215

## 0 Executive Summary

### *What is biomass CCS?*

In the context of this project, biomass power with Carbon Capture and Storage (CCS) has three main components:

- A biomass feedstock supply chain
- A power plant conversion system
- A carbon capture technology

Since each of these components has a variety of options, there are numerous potential combinations that can form a viable biomass CCS route. These generally involve the combustion or gasification of biomass (either in dedicated systems or co-fired with fossil fuels), combined with one of the three carbon capture categories (post-combustion, oxy-combustion or pre-combustion).

### *TESBIC project context*

CCS combined with fossil fuel based power generation is most commonly viewed as a bridging technology that will enable the transition to a longer-term solution, comprising only renewable energy sources. Some critics have argued that CCS might result in the perpetuation of fossil fuels as the dominant energy source, sometimes known as “reinforced fossil fuel lock-in”. Biomass CCS, on the other hand, has a negative carbon emissions potential, and can help to avoid this risk. In this way, CCS technologies developed in the near-term for fossil fuels can, when combined with biomass utilisation, form part of a renewable energy future.

ETI’s UK Energy System Model (EMSE) provides an evaluation of different options for meeting the UK’s future energy demand and emissions reduction targets at the least costs, out to 2050. ESME provides a compelling case for UK deployment of biomass CCS, due to its large, negative emissions, persistence across scenarios, and high option value. Global interest in biomass CCS is also increasing, with studies estimating a potential for -3 to -10 GtCO<sub>2</sub>/yr savings in the power sector by 2050.

However, the level of development activity on biomass CCS (especially with dedicated biomass) has been significantly lower than for fossil fuel based CCS. There are therefore significant gaps in our understanding of biomass CCS; particularly in terms of the key technical and economic barriers, as well as the potential for deployment in the UK to 2050. This TEBIC project sets out to address some of these issues.

The principal objective of the TEBIC project is to provide technical information and a set of recommendations that will contribute towards the development of a “biomass CCS roadmap”. It is envisaged that the results of this work will help ETI to guide the development and commercial deployment of biomass CCS, and to disseminate information on the benefits and risks associated with biomass CCS to potential stakeholders and the wider public.

### ***Structure of Work Package 1***

Within Work Package 1 (WP1) of the TESBIC project, Deliverable D1.1 focused on a landscape overview of current biomass based power generation and carbon capture technologies, and current global demonstration activities. Deliverable D1.2 assessed the various combinations of biomass power with CCS technologies, before recommending a shortlist of technologies for further detailed study in the rest of the TESBIC project.

This current document, Deliverable D1.3, is based on ETI's feedback from the Stage Gate Review meeting, and also includes an updated version of the D1.1 report. This report is structured as follows:

- **Section 2:** Reviews the individual biomass power and carbon capture technologies, covering their development status, key issues, scales of operation, efficiency, economics, emissions and UK activities and capabilities. Biomass feedstock properties and pre-processing requirements are also presented
- **Section 3:** Introduces the combinations and groupings of biomass power and carbon capture technologies, followed by an overview of worldwide demonstration projects
- **Section 4:** Describes the prioritised assessment criteria used in the selection of the technology combinations for further study. These criteria cover a range of different development, techno-economic, feedstock, feasibility and UK aspects
- **Section 5:** Presents the assessment for each of the biomass power and capture technology combinations, bringing together information from the individual component reviews
- **Section 6:** Recommends a shortlist of eight technology combinations to be taken forward. This shortlist includes at least one technology combination suitable for small-scale power applications. The key criteria for these combinations are compared side-by-side in a summary matrix

### ***Scope of Work Package 1***

Finalisation of the project scope with ETI led to the exclusion of waste feedstocks, technologies which would not be commercially deployed by 2050, technologies only applicable at scales below 10 MW<sub>e</sub>, the use of algae for CO<sub>2</sub> capture, biofuel refineries, downstream CO<sub>2</sub> transport and storage technologies, and natural gas combined cycle plants along with indirect and parallel co-firing options.

The following 11 co-firing and dedicated biomass conversion technologies have therefore been reviewed in Section 2.2:

- **Pulverised coal combustion**, with direct co-firing of biomass, or conversion to 100% biomass
- **IGCC coal gasification**, with direct co-firing of biomass, or conversion to 100% biomass
- **Dedicated biomass combustion:** bubbling or circulating fluidised bed or grate
- **Dedicated biomass gasification:** bubbling, circulating or dual fluidised bed, or entrained flow



14 carbon capture technologies have also been reviewed in Section 2.3:

- **Post-combustion** (Solvent scrubbing, Low-temperature solid sorbents, Ionic liquids, Enzymes, Membrane CO<sub>2</sub> separation, and High-temperature solid sorbents)
- **Oxy-combustion** (Cryogenic O<sub>2</sub> separation, Membrane O<sub>2</sub> separation, Chemical-looping-combustion using solid oxygen carriers)
- **Pre-combustion** (Integrated gasification combined cycle with physical absorption, Membrane H<sub>2</sub> separation, Membrane syngas generation, Sorbent enhanced reforming using carbonate looping, Zero-Emission Coal Alliance concept)

A range of UK and imported solid biomass feedstocks were also characterised in Section 2.4:

- **Forestry:** timber, short roundwood, forestry residues, arboricultural arisings
- **Woody energy crops:** willow, poplar, eucalyptus
- **Energy grasses:** miscanthus, switchgrass, reed canary grass
- **Agricultural residues:** wheat, barley and oil seed rape straws, imported olive, palm and sunflower residues, and bagasse
- **Waste wood:** sawdust, chip board, medium-density fibreboard

We have identified which chemical compositions, fuel and physical properties are compatible with different power conversion technologies, and if any pre-processing is required. The main issues with using biomass feedstocks are low ash fusion temperatures, along with high alkali and halide contents – due to slagging and agglomeration along with fouling and corrosion. There are few impacts on capture technologies of using biomass expected beyond those experienced using coal.

Many of the dedicated biomass technologies are able to take a wide range of biomass particle sizes and moisture contents, with little pre-processing required, although other mitigations such bed additives or temperature limits might be needed. In comparison, co-firing with coal generally requires small particle sizes – although milling energy consumption can be significantly reduced by torrefaction or pyrolysis pre-treatment.

UK forestry currently dominates power sector biomass consumption, with some UK straw and imported residues also used. The total available resource to the UK is likely to increase significantly to 2050, with imported energy crops expected to dominate. There will therefore be large supplies of feedstock available that are suitable for all combustion and gasification technologies; hence feedstock availability or suitability is not a deciding factor in the choice of which biomass CCS routes to progress.

### ***Technology combination assessments***

Using the information collected for each of the different power and capture technologies, we formed 28 feasible combinations of component technologies. The TESBIC project partners then assessed each combination against an agreed set of criteria, with the key benefits and risks highlighted in Section 5. The assessment criteria, discussed in Section 4, cover a range of different development, techno-economic, feedstock, feasibility and UK aspects. The most important criteria have been identified as the likely Technology Readiness Level (TRL) in 2020, key technical issues, plant efficiency with capture, capital costs with capture, and potential for UK deployment.

## **Recommendations**

During a full day internal workshop, based on the key advantages and disadvantages given in each combination assessment, the TESBIC consortium decided whether there were strong enough reasons to reject particular combinations, and provided evidence for these rejections. In summary, 20 of the 28 technology combinations have not been recommended for progression:

- Low-temperature solid sorbents, ionic liquids, enzymes and membrane CO<sub>2</sub> separation combinations (**3, 4, 5, 6, 5a, 6a, 7, 8**) potentially have reduced capital costs compared to amine scrubbing, but they generally only have marginal efficiency benefits, and there are uncertainties regarding operating costs, as well as several major technical issues yet to be resolved
- Membrane O<sub>2</sub> separation, membrane H<sub>2</sub> separation, membrane production of syngas, sorbent enhanced reforming and the ZECA concept combinations (**11a, 12a, 17, 18, 19, 20, 21, 22, 23, 24**) potentially have high plant energy efficiency, but there are numerous technical issues in addition to uncertain capital costs, and paucity of available data for the earliest stage concepts
- Dedicated biomass with carbonate looping (**10**) was not progressed, as it is not yet known if the calciner can be biomass-fired – i.e. co-firing percentages might be limited to <70%. Our recommendation is therefore to begin by exploring only the co-firing option (9)
- Co-firing chemical looping combustion (**13**) was not progressed, since coal gasification rates are slower than those for biomass, and unreacted char leads to carryover and loss of CO<sub>2</sub>. Also, chemical looping cannot be retrofitted to a pulverised coal plant – a CFB boiler is needed. Hence the dedicated biomass option (14) is preferred for progression instead

With feedback from the ETI Stage Gate Review meeting on 13<sup>th</sup> June 2011, this selection process left us with eight technology combinations recommended for progression:

- (1) Co-firing combustion, with post-combustion amine scrubbing
- (2) Dedicated biomass combustion with post-combustion amine scrubbing
- (9) Co-firing combustion, with post-combustion carbonate looping
- (11) Co-firing oxy-combustion, with cryogenic O<sub>2</sub> separation
- (12) Dedicated biomass oxy-combustion, with cryogenic O<sub>2</sub> separation
- (14) Dedicated biomass chemical-looping-combustion using solid oxygen carriers
- (15) Co-firing IGCC, with physical absorption
- (16) Dedicated biomass IGCC, with physical absorption

An overall view of the combinations recommended for progression or rejected is given in Table 0.1. This shows that our recommendations cover all three main capture categories, and also give an equal split between large-scale co-firing combinations and small-scale dedicated biomass combinations.

Internationally, the current set of CCS demonstration projects considering using biomass are mainly being developed in Europe, and most plan to be operational soon after 2015. As expected, these projects are only looking to co-fire biomass at modest percentages in the most mature coal CCS plant concepts – i.e. combinations (**1**), (**11**) and (**15**).

**Table 0.1: Power-capture technology combinations proposed for progression/rejection**

		Post-combustion					Oxy-combustion			Pre-combustion					
		Solvent scrubbing, e.g. MEA, chilled ammonia	Low-temp solid sorbents, e.g. supported amines	Ionic liquids	Enzymes	Membrane separation of CO <sub>2</sub> from flue gas	High-temp solid sorbents, e.g. carbonate looping	Oxy-fuel boiler with cryogenic O <sub>2</sub> separation	Oxy-fuel boiler with membrane O <sub>2</sub> separation	Chemical-looping-combustion using solid oxygen carriers	IGCC with physical absorption e.g. Rectisol, Selexol	Membrane separation of H <sub>2</sub> from synthesis gases	Membrane production of syngas	Sorbent enhanced reforming using carbonate looping	ZECA concept
<b>Coal IGCC gasification</b>	Direct cofiring	Not feasible					Not feasible			15	17	19	21	23	
	Conversion to 100% biomass	Not feasible					Not feasible			15	17	19	21	23	
<b>Pulverised coal combustion</b>	Direct cofiring	1	3	5	5a	7	9	11	11a	13	Not feasible				
	Conversion to 100% biomass	1	3	5	5a	7	9	11	11a	13					
<b>Dedicated biomass combustion</b>	Fixed grate	2	4	6	6a	8	10	12	12a	14					
	Bubbling fluidised bed	2	4	6	6a	8	10	12	12a						
	Circulating fluidised bed	2	4	6	6a	8	10	12	12a						
<b>Dedicated biomass gasification</b>	Bubbling fluidised bed	Not feasible					Not feasible			14	16	18	20	22	24
	Circulating fluidised bed	Not feasible					Not feasible				16	18	20	22	24
	Dual fluidised bed	Not feasible					Not feasible				16	18	20	22	24
	Entrained flow	Not feasible					Not feasible				16	18	20	22	24

### *Quantitative supporting data*

Further quantitative data is provided below for each technology combination, comparing factors such as the plant efficiency with capture, the CO<sub>2</sub> capture rate (Figure 0.1) and the estimated cost of avoided CO<sub>2</sub>. Full details and explanations are given in Section 6.3.

The quantitative data used has only been taken from the literature values and information already gathered and reviewed in Work Package 1. These are the best estimates available to us at this early stage of the TESBIC project – carrying out the detailed Case Studies and modelling in later Work Packages is required before more accurate figures can be given. Note that the error bounds on the estimates provided are especially large for the early stage technologies.

An illustrative measure of risks vs. rewards is given in Figure 0.2. The higher the TRL, and the fewer the number of development issues and technical showstoppers, then the lower the “risk” (x-axis). Cost of avoided CO<sub>2</sub> was felt to be an appropriate measure of the “rewards” (y-axis), since it includes a variety of economic factors such as capture rate, plant efficiency and capital costs with capture in its calculation, and is also a useful indication of the carbon prices required to enable competitive viability with unabated fossil fuel or biomass generation.

Figure 0.2 gives a clear justification for why the shortlist of 8 technologies was chosen for progression. These 8 technologies have the lowest risk, i.e. are further left on the x-axis, and hence are most likely to be developed in time for 2050 mass-deployment. Whilst attractive in terms of potential deployment, they still cover a broad range of avoided CO<sub>2</sub> costs:

- The ‘benchmark’ near-term cases of co-firing with amine scrubbing (**1**) and oxy-fuel with cryogenic O<sub>2</sub> separation (**11**) have average costs of avoided CO<sub>2</sub>
- The corresponding dedicated biomass systems (combinations **2** and **12**) are more expensive, and at a slightly earlier stage of development, but there are not expected to be major technical differences to the co-firing cases
- Both co-firing (**15**) and dedicated biomass (**16**) IGCC with physical absorption are cheaper than the options above, mainly due to their higher efficiencies. However, (**16**) has only been considered theoretically so far, and there is not a clear development pathway since the current BIGCC plants without capture are not well suited to adding capture. There are, however, no major technical showstoppers, and knowledge spill-over from (**15**) and biofuels applications could accelerate (**16**)’s development. Of the dedicated biomass gasification combinations, (**16**) is still a clear winner over (**18**), (**20**), (**22**) & (**24**), both in terms of risk and reward. There may also be interesting options for small-scale integration with future syngas infrastructure, or H<sub>2</sub> storage
- The more technically risky options of dedicated biomass Chemical Looping Combustion (**14**) and co-firing with post-combustion carbonate looping (**9**) show low costs of avoided CO<sub>2</sub>. (**9**) also has the potential benefit of cement industry decarbonisation at low cost. (**14**) could have even higher efficiencies (above 50%) via process integration options with gas turbines or H<sub>2</sub> production, and would appear to be the technology most suited to small-scale power applications

The summary matrix in Table 0.2 compares the key assessment criteria for each of the eight combinations recommended for progression.

Figure 0.1: Estimated plant LHV efficiencies with capture, and CO<sub>2</sub> capture rates, for each technology combination (error bars not shown)

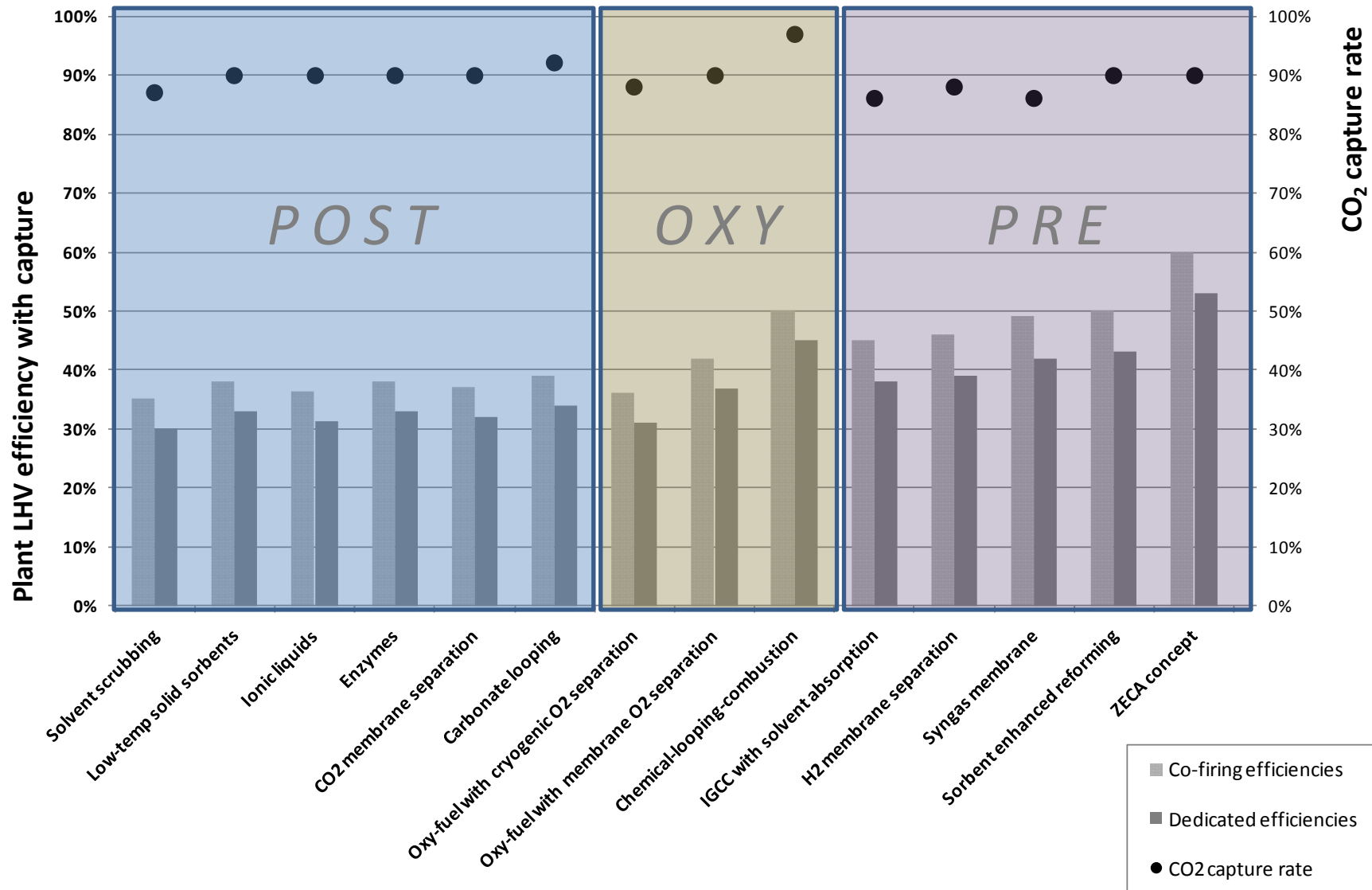
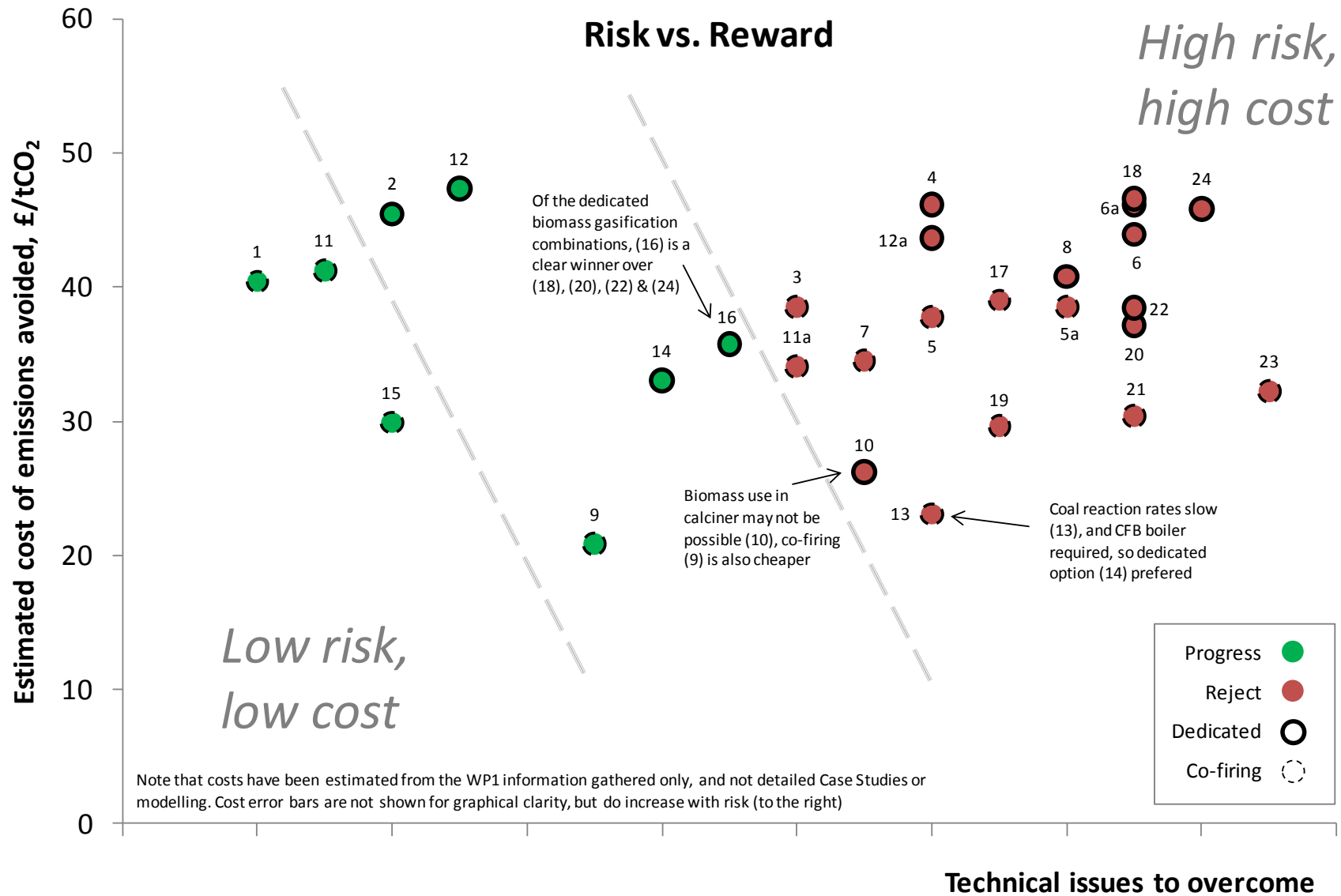

Figure 0.2: Estimated cost of avoided CO<sub>2</sub> vs. technical issues to overcome, for each technology combination (error bars not shown)



**Table 0.2: Summary matrix comparing key criteria for the recommended combinations**

Criteria	(1) Co-firing amine scrubbing	(2) Dedicated biomass with amine scrubbing	(9) Co-firing carbonate looping	(11) Co-firing oxy-fuel	(12) Dedicated biomass oxy-fuel	(14) Dedicated biomass chemical looping	(15) Co-firing IGCC	(16) Dedicated biomass BIGCC
<b>Current TRL</b>	6 to 7	4	4 to 5	6	5	4	5 to 6	4
<b>Likely TRL in 2020</b>	7 to 8	6 to 7	5 to 6	7	6	5 to 6	7	5 to 6
<b>Key technical issues</b>	Scale-up, amine degradation, potential losses to environment	Scale-up, amine degradation, potential losses to environment	Calciner firing, degradation, large purge of CaO	Corrosion, O <sub>2</sub> energy costs, slow response	Corrosion, O <sub>2</sub> energy costs, slow response	Loss in activity, reaction rates, dual bed operation	Complex operation, slow response, tar cleaning, retrofit unattractive	Complex operation, slow response, tar cleaning, retrofit unattractive
<b>Suitability for small scale</b>	Low	High	Low	Low	High	High	Low	High
<b>Plant efficiency with capture</b>	OK	Low	Good	OK Some gains with O <sub>2</sub> membrane	Low Some gains with O <sub>2</sub> membrane	Good High if at pressure, or H <sub>2</sub> for fuel cells	High, Very High with new gas turbines	Good, High with new gas turbines
<b>Capital costs with capture</b>	OK	Expensive	Low cost, although repowering requires capex	OK ASU costs could fall with O <sub>2</sub> membranes	Expensive ASU costs could fall with O <sub>2</sub> membranes	Low cost	OK, could fall with new gas turbines	Expensive, could fall with new gas turbines
<b>UK deployment potential</b>	Immediate capture retrofit opportunities, long-term doubtful	Numerous capture retrofit opportunities by ~2015, high long-term potential	Immediate capture retrofit opportunities, cement integration	Near-term retrofit opportunities, long-term doubtful	Numerous capture retrofit opportunities by ~2015, high long-term potential	Likely first demos in Europe, UK in ~2020. High long-term potential	No current UK plants, several demos by 2020, could co-fire. Long-term doubt	No current UK plants, demo unlikely by 2020. High long-term potential





## 1 Introduction to biomass power with CCS

This initial section introduces biomass-based power generation combined with carbon capture technologies; and presents the context, objectives and the scope of this report.

### 1.1 What is biomass CCS?

The international imperative to maintain average atmospheric CO<sub>2</sub> concentrations below targets of 450 ppmv<sup>1</sup> or even 350 ppmv<sup>2</sup> demands the rapid adoption of a wide range of technologies which are capable of meeting our demand for energy with minimal CO<sub>2</sub> emissions. Biomass-fuelled power generation technologies combined with carbon capture and storage (CCS), collectively referred here as “biomass CCS”, offers one approach which can contribute towards a sustainable energy future. They are regenerative in nature, and offer the potential to generate electricity with negative CO<sub>2</sub> emissions, by capturing CO<sub>2</sub> out of the atmosphere during the feedstock growing cycle, and storing the CO<sub>2</sub> from the power conversion process underground.

The term biomass refers to non-fossilised bio-derived material such as forestry products and residues, dedicated energy crops, agricultural residues, and the biogenic fraction of wastes. In the UK, the utilisation of biomass is expected to play an increasingly important role in meeting future renewable energy targets, such as the EU Renewable Energy Directive setting the UK a target of meeting 15% of final energy consumption from renewable sources by 2020.

The three key components of the full CCS chain constitute CO<sub>2</sub> capture from power plants, transportation of captured CO<sub>2</sub> to storage sites and finally its long-term underground storage. The numerous carbon capture options associated with power generation can be broadly classified within three categories: post-combustion, oxy-fuel combustion or pre-combustion.

Overall, a biomass CCS route consists of three main components:

- The biomass supply chain to the power plant site
- The power plant conversion system, based either on a dedicated biomass process or on co-firing the biomass with a fossil fuel
- The carbon capture technology, potentially integrated within the power plant conversion system

Since each of these components has a variety of options, there are numerous potential combinations that can form a viable biomass CCS route. As depicted at a high-level in Figure 1, a route usually involves the combustion or gasification of biomass (either dedicated or co-fired with fossil fuels), combined with one of the three generic carbon capture categories. Combining “carbon neutral” biomass power generation with “carbon negative” CCS technologies provides a near-market technological intervention strategy for achieving a rapid and significant reduction in the carbon intensity of the power generation sector.

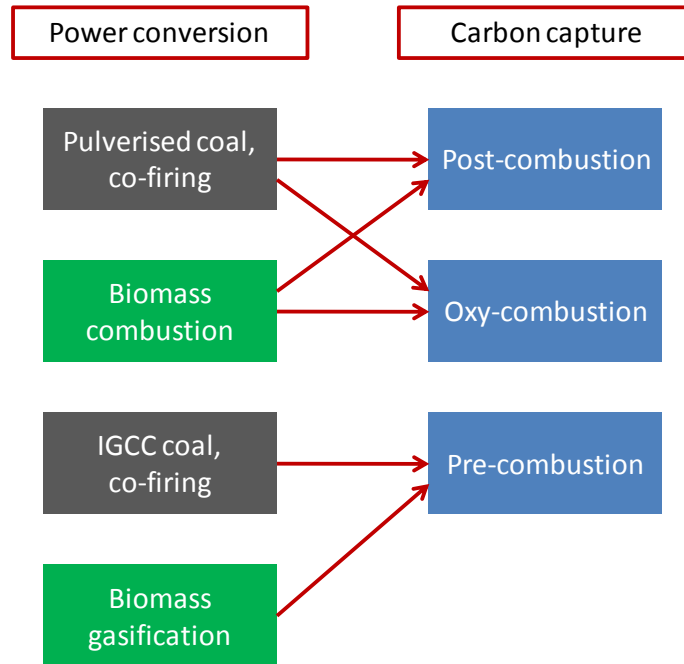

Figure 1.1: High-level combinations of power conversion and carbon capture technologies

## 1.2 Context

CCS combined with fossil fuel based power generation is most commonly viewed as a bridging technology that will enable the transition to a longer-term solution, comprising only renewable energy sources. Some critics have argued that CCS might result in the perpetuation of fossil fuels as the dominant energy source, sometimes known as “reinforced fossil fuel lock-in”. Biomass CCS, on the other hand, has a negative carbon emissions potential, and can help to avoid this risk. In this way, CCS technologies developed in the near-term for fossil fuels can, when combined with biomass utilisation, form part of a renewable energy future.

In the UK, the majority of industrial CO<sub>2</sub> emissions are attributed to the power generation sector<sup>3</sup>. ETI’s energy system model (EMSE) evaluates different least-cost options for meeting the UK’s future energy demand and emissions reduction targets, out to 2050. ESME provides a compelling case for biomass CCS, because:

- It is capable of generating large, negative, emissions of the order of -50 to -100 MtCO<sub>2</sub>/yr
- It is persistently selected for significant deployment in almost all scenarios
- It has a high option value – excluding it leads to a significant increase in overall system cost, since other options with significantly higher carbon savings costs have to be selected instead

Global interest in biomass CCS is increasing<sup>4</sup>. In their 2011 report for IEAGHG, Ecofys have estimated that the technical potential for biomass CCS in 2050 could be up to -10 GtCO<sub>2</sub>/yr in the power sector, i.e. meeting around a third of global electricity demand<sup>5</sup>. The realisable potential in 2050 is likely to be smaller, at up to -3 GtCO<sub>2</sub>/yr (around 10% of global electricity demand), with the largest opportunity being retrofitting CCS to co-firing coal combustion plants. However, under a carbon price of €50/tCO<sub>2</sub>, Ecofys expect that the global economic potential for biomass CCS will actually be dominated by gasification based routes, due to their lower production costs.

The estimates provided in other studies<sup>6</sup> have indicated that the net CO<sub>2</sub> reductions associated with biomass CCS could be in the range -140 to -1573 gCO<sub>2</sub>eq/kWh of generated power.

Despite the increasing interest globally, the level of development activity on biomass CCS (especially with dedicated biomass) has been significantly lower than for fossil fuel based CCS. There are therefore significant gaps in our understanding of biomass CCS; particularly in terms of the key technical and economic barriers, as well as the potential for deployment in the UK to 2050. This TESBIC project sets out to address some of these issues.

The principal objective of the TESBIC project is to provide technical information and a set of recommendations that will contribute towards the development of a “biomass CCS roadmap”. It is envisaged that the results of this work will help ETI to guide the development and commercial deployment of biomass CCS, and to disseminate information on the benefits and risks associated with biomass CCS to potential stakeholders and the wider public.

### 1.3 Objectives and structure of this report

Within Work Package 1 (WP1) of the TESBIC project, a draft version of the first Deliverable D1.1 was submitted in May 2011. This focused on a landscape overview of current biomass based power generation and carbon capture technologies, and current global demonstration activities.

The second part of WP1 assessed the various biomass power generation with CCS technologies, before recommending around five technologies for further detailed consideration in the rest of the TESBIC project. An Executive Summary and Presentation slide pack were provided as Deliverable D1.2, in time for the ETI’s Stage Gate Review (SGR) meeting on 13<sup>th</sup> June 2011.

This current document, “WP1 Detailed Final Report”, is based on the feedback and suggested D1.2 revisions from the SGR meeting, and also includes an updated version of the D1.1 report. This Deliverable D1.3 report is structured as follows:

- **In Section 2:** A review of the individual biomass power and carbon capture technologies, covering their development status, key issues, scales of operation, efficiency, economics, emissions and UK activities and capabilities. Biomass feedstock properties and pre-processing requirements are also presented
- **In Section 3:** Introduction to the combinations and groupings of biomass power and carbon capture technologies, followed by an overview of worldwide demonstration projects
- **In Section 4:** Description of the prioritised assessment criteria used in the selection of the technology combinations for further study. These criteria cover a range of different development, techno-economic, feedstock, feasibility and UK aspects
- **In Section 5:** Presents the assessment for each of the biomass power and capture technology combinations, bringing together information from the individual component reviews
- **In Section 6:** A set of recommendations are made, with a shortlist of eight technology combinations to be taken forward. This shortlist includes at least one technology combination suitable for small-scale power applications. The key criteria for these eight technology combinations are compared side-by-side in a summary matrix

## 1.4 Technology Readiness Levels

Technology Readiness Level (TRL) is a relative measure, first introduced by NASA, of the maturity of evolving technologies on a scale of 1 to 9. TRL 1 corresponds to basic research on a new invention or concept, whilst TRL 9 corresponds to a fully commercialised technology. The definitions of each TRL are given in Table 1.1.

Within the current project, the TRL values of the relevant technologies at their current stage of development and their likely TRL in 2020 have been assessed. In order to estimate future TRL values it is necessary to make judgements about the future pace of development of a particular technology. In this document, the estimated TRL values in 2020 are based on the expected achievable scales of lab units, demonstration or commercial plants, based on the current plant scales, and the current level of activity in the area. This is a relatively conservative view of technology development, based on past experience within the power industry.

However, it is worth noting that many organisations, including the US DOE, hold a much more optimistic view of TRLs. Any of the early stage technologies considered in this report could be accelerated to full scale demonstration scale (TRL 7 or 8) within 10 years if it were to become the specific target of a directed innovation effort, for example, through significant government R&D funding and/or incentives to build demonstration plants. A more likely situation for TRL acceleration might be if a specific technology is picked by a large industrial player, and there is heavy investment.

Therefore, it is worth noting that provided enough money is available, and there is a sufficient appetite for risk, then the TRL by 2020 of any particular technology could be significantly higher than we have estimated. However, our approach is more consistent across all the technologies considered, and is based on incremental research efforts only, rather than ‘picking winners’.

**Table 1.1: TRL definitions**<sup>7</sup>

TRL	Definition	Plant stage
1	Basic principles observed and reported	Basic research
2	Technology concept and/or application formulated	Theoretical research
3	Analytical and experimental critical function and/or characteristic proof of concept	Applied research
4	Technology component and/or basic technology sub-system validation in a laboratory environment	Bench-scale test rig
5	Technology component and/or basic sub-system validation in a relevant environment	Pilot plant
6	Technology system/subsystem model or prototype demonstration in a relevant environment	Small-scale demonstration plant
7	Technology system prototype demonstration in an operational environment	Full-scale demonstration plant
8	Actual technology system completed and qualified through test and demonstration	First commercial plants
9	Technology system “qualified” through successful mission operations	Mass deployment of fully commercial plants

## 1.5 Scope for the study

The work carried out under this project has been focussed, in the main, on the technology combinations that show strong potential for significant UK deployment within a 2050 timeframe. Biomass feedstock groups that are most likely to be available in large quantities in the UK, such as forestry, woody energy crops, energy grasses and straws, along with the more significant imported solid biomass materials, where available in large volumes, have been considered in this study.

The following technological areas and issues are deemed to be out of scope for this report, and this TESBIC project:

- Technologies that are not considered likely to be advanced enough to be able to contribute to significant UK deployment in 2050 have not been considered further in this study. For a technology to already be significantly deployed by 2050, the technology has to be commercially available by 2040 at the latest. Industry lead times from early demonstration to commercial availability are likely to be about 15 years, and so this means that if a technology cannot reach an early demonstration stage (TRL 5) by 2020, or 2025 at the latest, then it is unlikely to significantly figure in the UK energy system in 2050
- Downstream CO<sub>2</sub> transport and storage technologies are outside the scope of the project
- Biological capture using algae grown in ponds or bioreactors are not considered, since these methods do not provide permanent storage of the carbon
- Coal and gas power generation and capture technologies are only in scope when considering biomass co-firing applications
- Only biomass CCS applications for electricity generation are considered. The use of biomass primarily for the production of heat or biofuels is not within the scope of the project. Throughout this report, small-scale power applications refers to scales of operation between approximately 10 and 30 MW<sub>e</sub>, whilst large-scale power applications refers to >100 MW<sub>e</sub>
- The recovery of energy from wet biomass or limited resources such as sewage sludge, manures and macroalgae is not considered. Likewise, the utilisation of MSW or commercial & industrial wastes for power generation is not considered
- There are a number of approaches to the co-utilisation of biomass with coal in large power plants. Only the technologies which involve the direct co-firing of the biomass material into the power plant are considered, since these have dominated the biomass co-firing market to date, and are likely to continue to do so. Other plant configurations involving indirect or parallel co-firing are much more expensive, and the minimal industrial activity that has occurred in the past was mainly focused on the utilisation of wastes
- Similarly, because there is no industry experience or current interest in the indirect co-firing of biomass in a natural gas turbine, natural gas combined cycle (NGCC) combustion power plants have not been considered in the project

- 
- <sup>1</sup> IPCC (2007). Fourth Assessment Report, Working Group III: Mitigation of Climate Change, Intergovernmental Panel on Climate Change
- <sup>2</sup> Anderson, K. and A. Bows (2008) "Reframing the climate change challenge in the light of post-2000 emission trends." Philosophical Transactions of the Royal Society, 366: pp. 3863-3882
- <sup>3</sup> DTI (2006) "Industrial CO2 emissions and CO2 storage potential in the UK", Report No. COAL R308 DTI PUB/URN6/2027
- <sup>4</sup> Tim Dixon (2010) "Biomass and CCS: IEAGHG activities", Presentation at COP16/CMP6 Cancun, Available at: [http://www.ieaghg.org/docs/General\\_Docs/IEAGHG\\_Presentations/IEAGHG\\_Biomass\\_CCS\\_Cancun\\_1\\_Dec\\_v2.pdf](http://www.ieaghg.org/docs/General_Docs/IEAGHG_Presentations/IEAGHG_Biomass_CCS_Cancun_1_Dec_v2.pdf)
- <sup>5</sup> Ecofys (2011) "Potential for Biomass and Carbon Dioxide Capture and Storage", report for IEAGHG, available at: [http://bellona.org/filearchive/fil\\_Potential\\_for\\_Biomass\\_and\\_Carbon\\_Dioxide\\_Capture\\_and\\_Storage\\_IEAGHG\\_Ecofys.pdf](http://bellona.org/filearchive/fil_Potential_for_Biomass_and_Carbon_Dioxide_Capture_and_Storage_IEAGHG_Ecofys.pdf)
- <sup>6</sup> Gough, C. And P. Upham (2010) "Biomass Energy with Carbon Capture and Storage: a Review", Tyndall Centre for Climate Centre Research, Working Paper 147
- <sup>7</sup> Scottish Power Energy Networks (2007) "Innovation Funding Incentive: Annual Report", available at: <http://www.ofgem.gov.uk/Networks/Techn/NetwrkSupp/Innovat/ifi/Documents1/SP%20IFI%20Projects%200607%20-%20Issue%201.pdf>

## 2 Review of component technologies

### 2.1 Information gathered

As part of WP1.1, the TESBIC consortium gathered the information shown in Table 2.1 for each biomass power conversion technology and carbon capture technology considered in the scope of the project. The detailed assessment of combinations of these power and capture technologies, as carried out in WP1.2, is presented later in Section 4.

**Table 2.1: Information gathered on each component technology**

Category	Information gathered
<b>Introduction</b>	Description
<b>Development aspects and prospects</b>	Key drivers for development
	Key development issues/barriers, potential show-stoppers
	Main players internationally
	Pilot/demonstration/commercial plants and R&D activities
	UK activities and capabilities
	Current TRL, and likely TRL in 2020
<b>Technical and economic characteristics</b>	Equipment scales, suitability for small-scale applications (10 - 30MW <sub>e</sub> )
	Efficiency
	CO <sub>2</sub> capture rate
	Ability to load follow, flexibility
	Capex, opex
<b>Feasibility</b>	Maximum % co-firing allowable / dedicated biomass
	Ease of changing to high co-firing/complete conversion
	Implications of retrofitting capture versus new build

The review of biomass power conversion technologies is presented in Section 2.2, and the carbon capture technologies in Section 2.3. During this technology review, the TESBIC consortium separately gathered information for the solid biomass feedstocks in scope. This involved:

- Identifying the solid biomass feedstocks that are most likely to be utilised as feedstocks for biomass CCS plants, now and in the future
- Describing the physical forms, fuel properties and ash behaviour of these different feedstocks
- Introducing and describing the benefits and costs of the different pre-processing options
- Assessing the likely impact and suitability of each feedstock on the performance and integrity of each biomass conversion technology, and if any pre-processing is required

These feedstock considerations are presented in Section 2.4.

## **2.2 Biomass conversion technologies**

A number of biomass co-firing and dedicated biomass conversion technologies have been considered in this study. These vary widely in their scales of operation, development status, performance and economics. The following section provides a review, based on the assessment criteria above, for each of the following technologies:

- Pulverised coal combustion, with direct co-firing of biomass, or conversion to 100% biomass
- IGCC coal gasification, with direct co-firing of biomass, or conversion to 100% biomass
- Dedicated biomass combustion: bubbling or circulating fluidised bed or grate
- Dedicated biomass gasification: bubbling, circulating or dual fluidised bed, or entrained flow



### 2.2.1 Pulverised coal combustion, with direct co-firing or conversion to 100% biomass

Pulverised fuel combustion<sup>8</sup> was developed for the large scale utilisation of coal and other solid fuels for the generation of power and heat. A mixture of pulverised fuel and primary combustion air is injected into the combustion chamber. Combustion takes place within the furnace volume while the fuel is in suspension, and the heat is transferred to the furnace walls and then to the heat exchange tube banks as the combustion gases pass through the boiler. This has been the principal means of the generation of electricity from coal worldwide since the middle of the twentieth century.

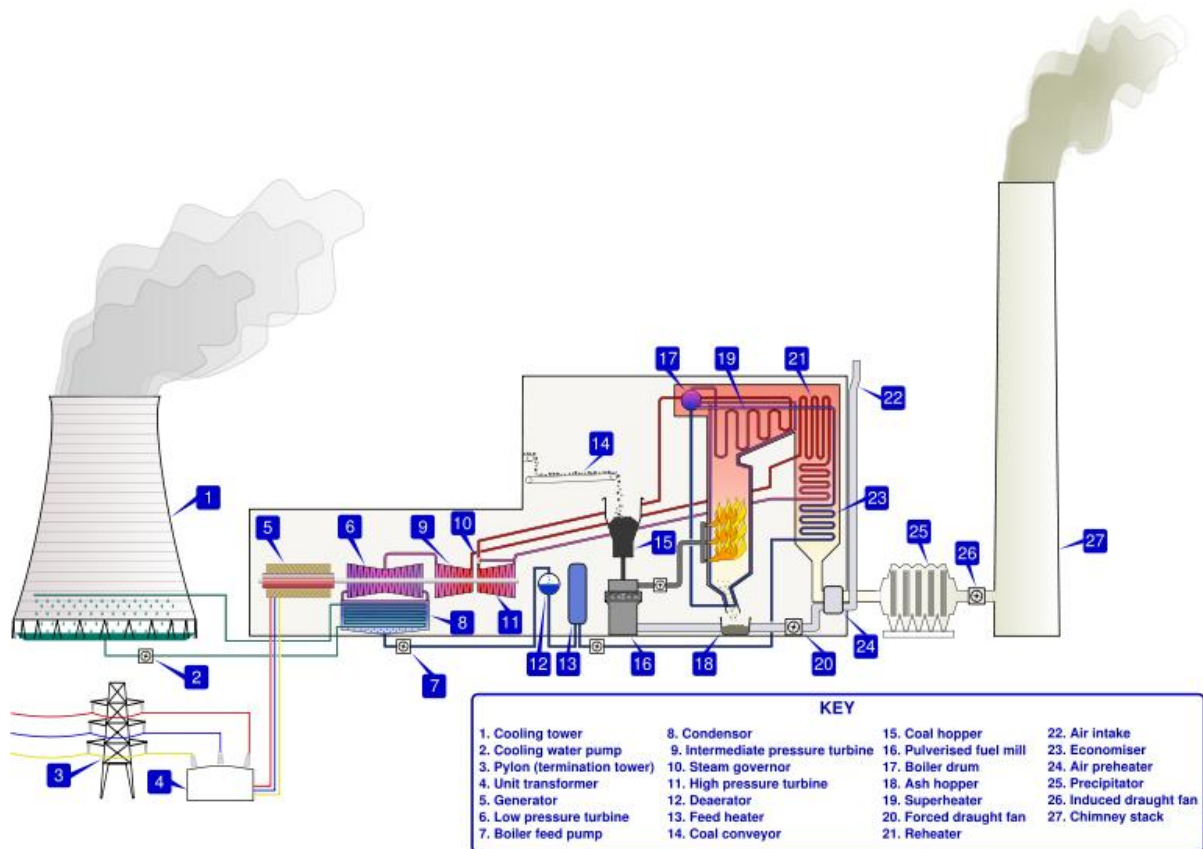

Figure 2.1: Generic schematic of a pulverised coal combustion power plant, without capture<sup>9</sup>

It has been predicted that, by 2030, steam coal utilisation worldwide will increase to around twice current levels and that up to around 50% of global power production will be from coal-fired plants. It is also projected that the market demand will increasingly be for high efficiency, clean coal power generation, with biomass co-firing capability and, in the longer term, with the capability to capture and store CO<sub>2</sub>.

It should also be noted in this context that coal is also burned in stoker-fired and fluidised bed-fired boilers; however these are relatively small in number and size compared to the large number of pulverised coal plants worldwide. There have also been significantly fewer biomass co-firing projects on stokers and fluidised beds compared to pulverised fuel boilers.

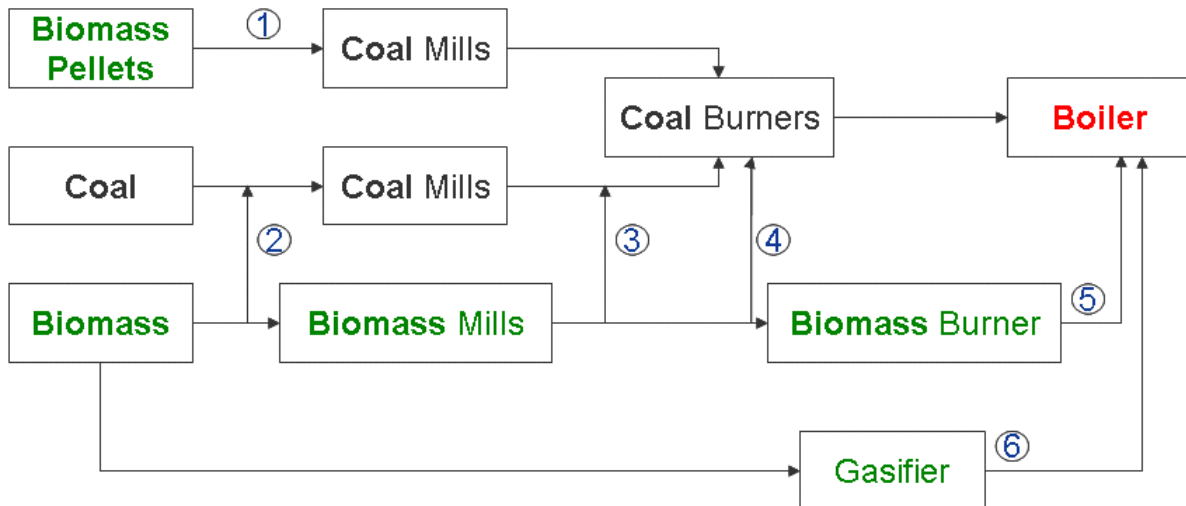

Figure 2.2: Biomass co-firing options at large pulverised coal-fired power plants

The more important technical options for the co-firing of biomass materials in large pulverised coal-fired boilers are summarised in Figure 2.2<sup>10</sup>, and include the following:

**Option 1** involves the milling of biomass materials (usually in the form of pellets) through the existing coal mills, after suitable modification, and the combustion of the milled biomass through the existing pulverised coal firing system, again with modification, if required.

**Option 2** involves the pre-mixing of the biomass with coal, in the coal handling system, at modest co-firing ratios, and the milling and firing of the mixed fuel through the existing coal firing system.

**Options 3, 4 and 5** involve the direct injection of pre-milled biomass into the pulverised coal firing system, i.e.

- into the pulverised coal pipework,
- into modified burners, or
- into new dedicated biomass burners

These options involve higher levels of capital investment, but significantly higher co-firing ratios can be achieved than are possible with Option 2.

**Option 6** involves the gasification of biomass in a dedicated unit, normally air blown and at atmospheric pressure, and the co-combustion of the product gas in the pulverised coal boiler. The product gas may or may not be cleaned prior to firing into the coal boiler. Option 6 has been adopted in only a very small number of plants in Northern Europe, and is not considered further.

All of the biomass co-firing scenarios for large coal-fired utility boilers listed below are in current commercial operation, or are being developed by power plant operators in Europe. It is fair to say, however, that Option 2 has been by far the most popular, principally because it makes use of the existing coal conveying, bunkering, milling and firing systems and hence requires the minimum capital expenditure.

All of these scenarios have involved the retrofitting of co-firing capability to existing plants, and have significantly different implications on the achievable co-firing ratio, the fuel flexibility of the co-firing system, the delivered biomass fuel costs, and the capital and operating costs of the biomass co-firing systems.

## *Development aspects and prospects*

### ***Key drivers for development***

The principal driver for the increasing demand for the capability to co-fire biomass materials in new and existing coal boiler plants is that co-firing is regarded as representing a very attractive option for biomass utilisation, and for the delivery of renewable energy, in terms of the capital investment requirement, security of supply, power generation efficiency and generation cost. This combination of high biomass power generation efficiencies and low capital cost outlay has been recognised by a number of European countries and other governments, who have introduced specific financial instruments to encourage biomass utilisation in general, and co-firing activities at existing and future coal-fired power plants.

The selection of the co-firing option would commonly be made on the basis of minimum interference with normal plant operations, and this may favour the installation of dedicated biomass handling and processing equipment if the ratio of biomass in the fuel mix to the boiler is greater than certain limits<sup>11,12,13,14</sup>. In many applications, the key driver for the current developments is the aspiration of the plant operators to increase the co-firing ratio, or increasingly to convert coal-fired boilers to 100% biomass firing.

### ***Demonstration and commercial plants***

The application of **Option 1**, as defined above, has been demonstrated in a small number of cases in Northern Europe. It has been shown that large, vertical spindle coal mills can be employed, with fairly modest modifications, to reduce dried and pelletised biomass back to something close to the primary particle size distribution, and that the mill product material can be fired successfully through the existing pulverised coal pipework systems and burners. This approach to co-firing, or to 100% conversion of coal fired boilers to biomass, is in the demonstration phase, and further demonstrations are planned in the short term future both in Europe and North America.

**Option 2** has been by some way the most popular approach to co-firing, as it can be implemented relatively quickly and with modest capital investment. The great majority of biomass co-firing in the UK and in much of Northern Europe is by pre-mixing biomass with coal, normally in the existing coal handling and conveying system. The mixed fuel is then processed through the installed coal bunkers and mills, and the installed pulverised coal firing equipment. This approach has been well demonstrated and can be regarded as being established technology.

**Options 3, 4 and 5** involve higher levels of capital investment, but significantly higher co-firing ratios can be achieved than are possible with Option 2. A number of coal-fired power plants in the UK and Northern Europe have installed direct injections systems over the past few years, and this is likely to be one of the favoured options for the provision of biomass co-firing capabilities in new build coal power plant projects.

All of the relevant technical approaches to direct injection co-firing involve the pre-milling of the biomass to a particle size distribution that will provide high combustion efficiency in a pulverised fuel flame, and all involve pneumatic conveying of the pre-milled biomass from the biomass handling/milling facilities to the boilers.

### ***Implications of changing to high % co-firing/complete conversion***

There are three basic direct co-firing options for the pre-milled biomass in retrofit applications, viz:

- The installation of new dedicated biomass burners, with the associated fuel and combustion air supply systems
- The injection of the biomass directly into the existing coal burners, after suitable modification
- The injection of biomass into the pulverized coal pipework or at the burner, and co-firing with coal through the existing burners (Option 3)

#### *Dedicated biomass burners*

The installation of dedicated burners for the co-firing of biomass materials as a retrofit in existing boiler plants may have some attractions. In most applications, it will be desirable to maintain the coal firing capability, i.e. the co-firing of the biomass will be additional to the co-firing, and new locations have to be created for the biomass burners. There will, in most cases, be a number of technical and commercial risk areas, and significant problems to be resolved.

There are a number of co-firing systems in Europe that have been based on the installation of dedicated biomass burners within coal-fired boilers, although it is fair to say that, to date, the accumulated plant experience to date is not extensive, and not all of the experience to date has been successful.

#### *Direct injection through modified coal burners*

The direct injection of the pre-milled biomass into the existing coal firing system may involve significant modification of the burners. This approach may be relatively expensive and may involve significant technical risk. This may be necessary for some biomass materials, where there is concern about the potential for blockage of the pulverised coal pipework system. These instances are likely to be relatively rare. To date this approach has only been applied in very few cases.

#### *Direct injection to the pulverised coal pipework*

The principal alternative is to introduce the biomass into the pulverised fuel pipework upstream of the coal burners. In this case, the pulverised coal/biomass mixture is carried forward along the existing coal pipework, and then enters the combustor via the pulverised coal burners, as normal. This type of approach is, in principle, applicable to all types of firing system and all burner designs, and may be the most popular of the available approaches to direct injection co-firing.

Overall, therefore, the direct injection options have been implemented in a relatively small number of power plants, principally in Northern Europe, and this technology is clearly in the demonstration phase. Direct injection of the milled biomass into the pipework is the simplest, cheapest and easiest to implement and will most likely become most popular for further replication.

#### *Direct injection biomass co-firing systems for new build applications*

For new build applications, the direct injection of the pre-milled biomass into the pulverised coal pipework has significant additional attractions in that the combustion system and boiler design risks can be reduced significantly:

- The biomass co-firing system is essentially additional to the coal milling and firing equipment, which can be designed largely as normal for a coal boiler
- This also means that the coal firing capability of the boiler plant is not compromised in any significant way by the provision of the biomass co-firing capability

- The co-firing of biomass through one or more of the coal mill burner groups, at up to 50% heat input, will only have a very modest impact on the furnace heat absorption, i.e. the current combustion system and furnace design rules can be applied with only minor modifications
- The products of combustion of the biomass are always pre-mixed with at least the same amount of those of coal combustion, with reduced risks of localised ash deposition and corrosion effects due to biomass firing

### ***Main players internationally***

The main technology developers and equipment suppliers for biomass co-firing and the conversion of coal boilers to 100% biomass firing are the major power plant boiler makers, e.g. Doosan Power Systems, Alstom, Hitachi etc. and the suppliers of the biomass processing and handling storage equipment and systems.

### ***Key development issues***

One of the key areas of concern in any biomass co-firing and biomass conversion project is the potential for significant impacts on the performance and integrity of the boiler. One of the key subject areas is concerned with the determination of the nature and scale of the changes in the converted boiler flame shapes and temperatures and the impact of the difference in the flue gas and fly ash flow rates on heat transfer surfaces and particulate collection facilities. Until detailed plant measurements are made, there remains some uncertainty about how the layout of the boiler heating surfaces and the combustion chamber will interact with the combustion process in terms of steam temperatures, corrosion and fouling, and whether this will require significant modification of the steam passes or to power plant components such as air heaters and fans.

The flue gas and fly ash from dedicated biomass firing are generally significantly more aggressive than those from coal firing with respect to its potential to cause ash deposition on boiler surfaces, and accelerated metal wastage of superheater/reheater surfaces, due to high temperature corrosion. Restrictions on the fuel composition may therefore be a feature of operation at high co-firing ratios and on boilers converted units to 100% biomass. There may also be a requirement to re-tube parts of the boiler and to make use of chemical additives to control the boiler tube corrosion processes.

The compliance with existing and future emission limits is an important issue which needs to be considered in the development of the technology for biomass co-firing, and for future CCS addition. For example, Selective Catalytic Reduction (SCR) is an established technology for the conversion of flue gas NO<sub>x</sub> into nitrogen and water, using ammonia. However, catalyst layers can suffer from 'poisoning' when combusting specific biomass fuels, particularly those with high concentrations of potassium and phosphate. This factor may effectively prevent the application of SCR on units with a high level of co-firing or on dedicated biomass conversion units.

### ***UK activities and capabilities***

In the UK, all of the large coal-fired power stations have co-fired biomass materials, at least on a trial basis, although the level of activity has varied widely from station to station. The majority of the biomass co-firing activity in the UK was by pre-mixing the biomass with the coal and co-milling, and a

number of the stations have been co-firing a wide range of biomass materials by this method since 2002.

A number of British power plants are currently involved in conversion projects aimed at providing a significant increase in the quantities of biomass fired at the stations, either by co-firing or conversion to 100% biomass firing.

Overall, in terms of the total quantities of biomass fired and co-fired, and the technical status of the biomass co-firing and conversion projects, the UK has a significant world lead.

### ***Technology Readiness Level***

As stated above, the co-firing of biomass in coal-fired power stations is either fully commercial or is in the large scale demonstration phase, depending on the specific co-firing technology being considered. An overall TRL value of 8-9 currently, and TRL 9 by 2020 would appear to be appropriate.

### ***Environmental factors***

In general terms, the biomass materials have lower levels of the prescribed pollutant species than the coals being fired. The experience in biomass co-firing in the UK and elsewhere has indicated that there has been little or no evidence of any significant negative environmental impacts associated with the large coal-fired boilers, when co-firing biomass at co-firing ratios less than 20% on a mass basis. At higher co-firing ratios, the risks of negative impacts may be increased and in some cases this may result in increased capital expenditure on pollutant abatement equipment and higher operating costs.

The principal environmental concerns on biomass co-firing projects to date have been associated with the risks of the generation of fugitive dust emissions and, in some cases, the smell from the biomass reception and handling activities. Both of these concerns have applied mainly to operation under trial conditions, rather than to full scale operational activities. For long term operation, the power plant operators have made significant investments and have controlled these emissions to the satisfaction of the environmental regulator.

### ***Technical and economic characteristics***

#### ***Equipment scales***

The majority of biomass co-firing projects to date have involved the retrofit of existing power plant boilers, with electricity generation capacity generally in the range 100-660 MW<sub>e</sub> to permit the co-firing of the biomass at relatively low co-firing ratios, up to 10% on a heat input basis. There has been much less activity at smaller industrial scales of operation.

The majority of the capital expenditure on the biomass co-firing retrofit projects to date has been associated with the installation of new biomass reception, handling, storage and pre-processing facilities. The extent of the biomass facility required depends on the co-firing technology and the biomass throughput.

#### ***Flexibility***

One of the principal attractions of a pulverised coal fired boiler is the high level of flexibility in operation, in terms of the ability to start-up and shutdown rapidly, and to follow load demand. In general terms, the biomass co-firing systems are engineered in such a way as to minimise the

impacts on the performance and integrity of the coal-fired boiler plant, and generally, the impacts of conversion to co-firing or to 100% biomass firing on plant operational flexibility are small.

### ***Efficiency without capture, economics***

The most detailed recent information on the CO<sub>2</sub> emissions and the economics of new build biomass firing and co-firing power plants are contained in the results of a 2009 study carried out by Foster Wheeler for IEAGHG<sup>15</sup>. The study work involved an evaluation of a number of cases which are directly relevant to the current project:

- Case 1: 500 MW<sub>e</sub> (net) co-firing of biomass and coal in pulverized fuel power plant
- Case 2: 500 MW<sub>e</sub> (net) co-firing of biomass and coal in circulating fluidized bed power plant
- Case 3: 250 MWe (net) circulating fluidized bed standalone biomass power plant
- Case 4: 75 MWe (net) bubbling fluidized bed standalone biomass power plant

The key features, performance and economic data of the power plant cases are given below in Table 2.2. The net efficiencies on a lower heat value (LHV) basis are around 45% for the larger boiler plants, i.e. the 500 MW<sub>e</sub> pulverised coal boiler and the 500 MW<sub>e</sub> CFB. It should be noted, however, that the CFB is fitted with a novel plastic heat exchanger for additional heat recovery from the flue gases: the best-in-class CFB plants commercially available today only have efficiencies of around 40%.

As would be expected, the net efficiencies for the smaller plants are significantly lower, i.e. around 42% for the 250MW<sub>e</sub> CFB also fitted with the novel plastic heat exchanger, and around 36% for the 75 MW<sub>e</sub> bubbling fluidised bed plant (which also has the highest specific capital costs). This highlights one of the main advantages of biomass co-firing: by using high efficiency large-scale coal boilers, biomass power generation can be achieved at much higher efficiencies than would be possible using a dedicated biomass plant of the same biomass input scale.

**Table 2.2: Summary of key features and performance of the co-fired or dedicated biomass power plants**

Case	Biomass Thermal Input (%)	Key Technology Features	DeSO <sub>x</sub>	DeNO <sub>x</sub>	Net Power Output (MW)	Net LHV efficiency (%)	Total Investment cost (£ <sub>2011</sub> m)	Capital cost (£ <sub>2011</sub> /kW <sub>e</sub> net)
<b>Supercritical PC, co-fired with biomass</b>								
1A	10	None	FGD	SCR	518.9	44.8	578	1,114
<b>Supercritical CFB, co-fired with biomass</b>								
2A	10	Plastic HEX for flue gas heat recovery	Limestone injection in furnace	None	521.4	45.1	622	1,193
<b>Subcritical CFB, dedicated biomass</b>								
3A	100	Plastic HEX for flue gas heat recovery	None	None	273	41.7	326	1,193
<b>Subcritical BFB, dedicated biomass</b>								
4A	100	None	None	None	75.8	36	163	2,152

A comparison of the CO<sub>2</sub> emissions for the four cases is presented in Table 2.3. Again, the data for the two co-firing cases are fairly similar, at around 750 gCO<sub>2</sub> per kWh power output. For the dedicated biomass plants operating at significantly lower cycle efficiencies, emission levels are higher, at values in excess of 1,000 gCO<sub>2</sub> per kWh power output.

**Table 2.3: Summary of CO<sub>2</sub> emissions of the biomass fired or co-fired power plant**

Case	Actual CO <sub>2</sub> emissions (g/kWh)	CO <sub>2</sub> from coal (g/kWh)	CO <sub>2</sub> from biomass (g/kWh)	Equivalent CO <sub>2</sub> emissions (g/kWh)
<b>Supercritical PC co-fired with biomass</b>				
1A	748.5	649.7	98.8	649.7
<b>Supercritical CFB co-fired with biomass</b>				
2A	748.2	649.4	98.8	649.4
<b>Subcritical CFB fired with biomass</b>				
3A	1081.3	0	1081.3	0
<b>Subcritical BFB fired with biomass</b>				
4A	1257.3	0	1257.3	0

Compared to the installation of dedicated biomass power plants, the co-firing of biomass makes use of the large capital investment and infrastructure associated with the existing fossil fuel-based power systems, and requires only the relatively modest capital investment associated with the reception, storage handling, processing and firing of the biomass.

The economics of biomass co-firing systems are complex and vary markedly from case to case, depending on the biomass fuel, the technical approach and the co-firing ratio. In general terms, the major element of the capital investment is associated with the fuel reception, storage and handling facilities. For recent large co-firing retrofit schemes in Europe, the capital costs of the biomass storage, handling and co-firing systems have been of the order of €200 - 400 per kW<sub>e</sub> of co-firing capacity (175 - 350 £<sub>2011</sub>/kW<sub>e</sub>).

The levels of additional operating cost associated with the biomass co-firing systems are generally fairly modest, compared to those for the coal firing system. The overall economics of biomass co-firing are largely dependent on the relative delivered fuel costs for the biomass and the coal. The values in the Foster Wheeler report above indicate that the fuel cost ratio, biomass: coal, is of the order of 3:1 on a heat input basis.

### ***Feedstock and feasibility***

Specific information about fuel characteristics of a wide range of biomass materials can be found in the databases developed by IEA Bioenergy Task 32, Institute of Chemical Engineering at the University of Technology, Vienna, the Netherlands Energy Research Foundation, and US Department of Energy<sup>16,17,18,19</sup>. The types of biomass that are currently used in dedicated or co-firing power plants can be classified as follows<sup>20</sup>:

- Granular agricultural materials, such as the solid residues from the palm oil and olive oil industries, and woody biomass, in the form of chips, chunks and sawdust.



- Herbaceous (grassy) biomass, baled materials are generally not suitable for co-firing by pre-blending.
- Pelletised biomass e.g., cereal co-product, dry sawdust, olive residue

In general terms, the majority of the biomass materials utilised for co-firing in coal-fired power plants are cleaner than the coals that are normally fired, in that they have much lower concentrations of the prescribed pollutant species. With some biomass materials, there may be concerns about high chlorine and alkali metal contents, which can lead to increased risks of excessive ash deposition on boiler surfaces, increased metal wastage rates of high temperature boiler components and of negative impacts on SCR catalyst performance. These risks are minimised by close control of the delivered fuel specification, by reducing the co-firing ratio if necessary and, in some cases, the use of fireside additives can be of value.

#### ***Pre-processing requirements***

All fuels have pre-processing requirements and in the case of biomass materials utilised for co-firing with coal, the pre-processing may involve, drying, size reduction, pelletising to increase the bulk density for transport and storage purposes, and/or milling to a topline of a few mm for direct injection to a pulverised coal firing system. This depends entirely on the nature of the biomass and the co-firing method.

#### ***Maximum co-firing ratio/conversion to 100% biomass firing***

In most of the projects to date, the biomass has been co-fired at relatively modest co-firing ratios. This permits a fairly wide range of biomass qualities and can be achieved at modest cost and with little risk of negative impacts on the plant performance and integrity. The co-firing ratio can be increased, to higher levels and even to 100% in most cases, although the fuel specification will become increasingly tighter at the elevated co-firing ratios.

#### ***Implications of retrofitting versus new build***

Over the past ten years or so, biomass co-firing, principally by pre-mixing the biomass with the coal and co-milling, has been applied in retrofit projects to a significant number of coal-fired boilers worldwide. The application to new build coal boilers is also relatively straightforward, either by pre-mixing and co-milling or by installing a direct injection system. A number of detailed designs for these systems for new-build boilers have been prepared, although there have been, as yet, no systems of this type installed.

- 
- <sup>8</sup> The Handbook of Biomass Combustion and Co-Firing, Edited by Sjaak van Loo and Jaap Koppejan, ISBN:978-1-84407-249-1, published by Earthscan, 2008.
- <sup>9</sup> Electrical and Electronics.org, "Steam Power Plant", accessed 16<sup>th</sup> June 2011, available at: <http://electricalandelectronics.org/wp-content/uploads/2008/09/steam-power-plant.png>
- <sup>10</sup> Livingston, W.R., and Morris, K.W., Experience with Co-Firing Biomass in PC Boilers to Reduce CO<sub>2</sub> Emissions, Power-Gen International, Las Vegas, 2009.
- <sup>11</sup> Livingston, W.R., and Morris, K.W. (2009) "Experience with Co-Firing Biomass in PC Boilers to Reduce CO<sub>2</sub> Emissions", Power-Gen International, Las Vegas.
- <sup>12</sup> The Handbook of Biomass Combustion and Co-Firing, Edited by Sjaak van Loo and Jaap Koppejan, ISBN:978-1-84407-249-1, published by Earthscan, 2008.
- <sup>13</sup> Colechin, M., and Malmgren, A., Best Practice Brochure: Co-Firing of Biomass (Main Report), Report No: COAL R287 DTI/Pub URN 05/1160, May 2005.
- <sup>14</sup> Sebastian, F., Royo, J., Gomez, M., Cofiring versus Biomass-Fired Power Plants: GHG Emissions Savings Comparison by Means of LCA Methodology, Energy, 1-9, 2010.
- <sup>15</sup> IEA Greenhouse Gas R&D Programme, Biomass CCS Study, Report Number:2009/9, November 2009.
- <sup>16</sup> IEA Bioenergy Task 32 on Biomass Combustion and Co-firing has prepared a database available at <http://www.ieabcc.nl>
- <sup>17</sup> The BIOBIB Database was developed by the Institute of Chemical Engineering, Fuel and Environmental Technology at the University of Technology, Vienna, Austria, available at <http://www.tuwien.ac.at>
- <sup>18</sup> The Phyllis Database is developed by the Netherlands Energy Research Foundation (ECN) available at <http://www.ecn.nl/Phyllis>
- <sup>19</sup> U.S. Department of Energy – Energy Efficiency and Renewable Energy, Biomass Program Database, available at [http://www1.eere.energy.gov/biomass/feedstock\\_databases.html](http://www1.eere.energy.gov/biomass/feedstock_databases.html)
- <sup>20</sup> Livingston, W.R., A Review of the Recent Experience in Britain with the Co-Firing of Biomass with Coal in Large Pulverized Coal-Fired Boilers, Presented at IEA EXCO Workshop on Biomass Co-Firing, Copenhagen, 2005.

## 2.2.2 IGCC coal gasification, with direct co-firing or conversion to 100% biomass

The Integrated Gasification Combined Cycle (IGCC) process has 4 main components (see Figure 2.3):

- Air separation unit (ASU)
- Solid fuel preparation and gasification
- Syngas cleaning and de-dusting
- Power generation with combined cycle (gas turbine with heat recovery and steam turbine)

Solid fuels are crushed and partially oxidised with oxygen to give the heat needed by endothermic gasification reactions of coal with steam. The produced syngas is then composed with incompletely burned gases with major components as CO and H<sub>2</sub> and with minor components such as methane, CO<sub>2</sub>, HCl, HCN, ammonia, H<sub>2</sub>S, COS and residual N<sub>2</sub> and Ar remained in the oxygen used in the gasifier. There is no significant presence of O<sub>2</sub>, NO<sub>2</sub> or SO<sub>2</sub> in the syngas.

The syngas is then cooled, dedusted and washed in order to remove alkaline gases and minor acid gases. This later operation increases also dust removal efficiency by retaining in the wash water some amount of particles. After COS conversion into H<sub>2</sub>S in hydrolysis catalyser, the H<sub>2</sub>S is removed using chemical solvents (high grade amines activated with e.g. piperazine) or physical solvents (Selexol™, using polyethylene glycol dimethyl ether, or Rectisol™ using chilled methanol). The Claus unit transforms the captured H<sub>2</sub>S into pure sulphur, which can then be sold as a co-product.

The clean syngas is then diluted with waste nitrogen provided by the ASU before input into the combustion chamber of the gas turbine. The nitrogen dilution increases syngas volume and decreases the NO<sub>x</sub> production of the gas turbine by lowering the combustion temperature. The flue gas heat from the gas turbine is recovered in order to generate steam, which is expanded in a steam turbine to generate additional power.

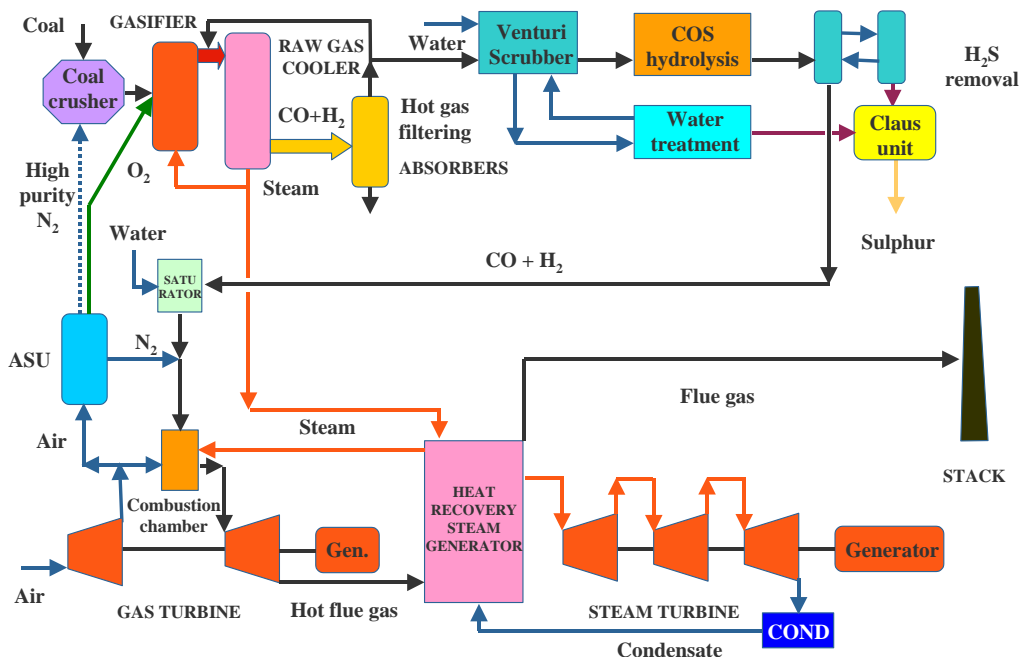

Figure 2.3: Generic schematic of an IGCC plant, without CO<sub>2</sub> capture

## **Development aspects and prospects**

### **Key drivers for development**

Coal IGCC started its development in the early 1980's after the first oil crisis. As the technology uses coal – a resource spread across the globe with expected reserves lasting centuries – the avoidance of geopolitical constraints was seen as a key advantage at the time.

However, IGCC technology has lost some interest in the last decade because of increased interest in shale gas<sup>21</sup>, which has been discovered in wide quantities in USA and also in Europe. Cheap gas supplies could lead to gas combined cycle plants continuing to be more economically competitive than coal IGCC, especially as gas combined cycle plants are flexible enough to load follow network variations, whilst coal IGCC plants do not have this flexibility. The technology also faces competition from the recent arrival of high efficiency Ultra-Supercritical coal combustion.

Several types of coal gasifier exist (see Figure 2.4), with different process configurations: air gasification, oxygen gasification, dry coal gasification, coal-water slurry gasification, entrained bed gasifier, fluidised bed gasifier, radiant gasifier, and gasifiers where the produced synthetic gas (syngas) is cooled with cooler syngas (gas-quench) or with water (water-quench). The vast majority of coal gasifiers are entrained flow, with few fluidised beds or other designs used, due to the required scales, pressurised operation and high temperatures.

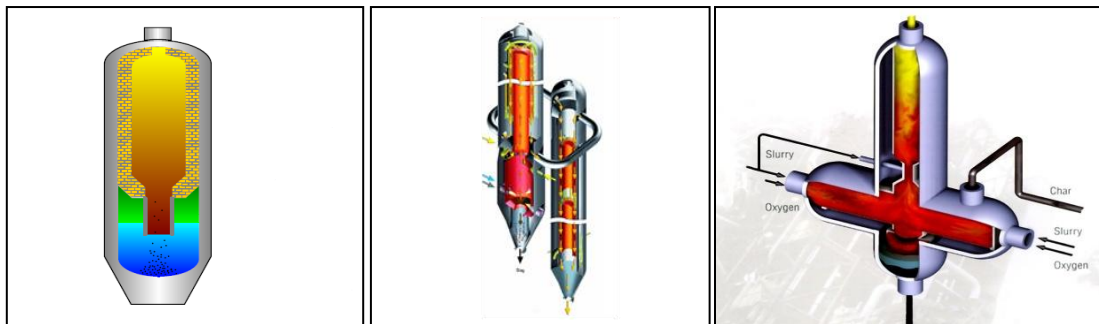

**Figure 2.4: Different coal gasifiers, from left to right, GE, Shell, ConocoPhillips**

Oxygen-blown gasification using dry coal in radiant entrained bed is the most efficient technology – this is the plant configuration shown in Figure 2.3. Slurry gasification is less efficient because the slurry cannot contain more than 64% solids<sup>22</sup> and therefore needs more oxygen to evaporate the excess water compared to dry coal gasification. Slurry gasifiers can be operated at very high pressure (over 60 bar), for the benefit of both economics (volume reduction of materials) and CCS (easier physical solvent regeneration by pressure flashing). However, compared to radiant gasifiers, these benefits are balanced by efficiency losses due to the excess slurry water and non-recovered heat.

### **Main international players**

The main gasifier manufacturers are:

- GE Energy, offers different versions of (ex-Texaco) gasifiers: their highest performance gasifiers (avoiding the water-quench impact on efficiency) are also the most expensive. GE also now offers guaranteed 600 MWe IGCC turnkey power plants

- Mitsubishi Heavy Industries (MHI) also offer turnkey IGCC power plants
- ConocoPhillips (COP) has offered E-Gas technology since 2003
- Shell offer different variant of its SGP gasifier depending on the targeted market
- Uhde's PRENFLO process is based on the Koppers-Totzek coal gasification process. Uhde also offer High-Temperature Winkler (HTW) fluidised bed gasifiers
- ECUST (East China University of Science & Technology) and TPRI (Thermal Power Research Institute), have developed gasifier technology in China. Although currently below  $\leq 250 \text{ MW}_e$ , these gasifiers are offered for export
- Siemens, bought German "GSP" technology and increased its capacity in order to offer high capacity turnkey IGCC power plants
- KBR/Southern Co offer a new gasifier technology "KBR Transport gasification technology" suitable for lignite
- Air Liquide bought Lurgi in 2007 and now offers high capacity moving bed gasifiers: Mk4 (80 sold) and Mk5E (4 projects in development).

#### ***Key development issues, flexibility***

Some availability problems remain in installed IGCCs, with the load factor of some existing IGCC plants not exceeding 80%. This low availability is specific to coal IGCC, and mainly due to difficulties in solid fuel handling. Full process integration between gas turbine, air separation unit (ASU fed with compressed air coming from gas turbine compressor) and gasification unit leads also to longer starting-up of the power plant and to a decreased availability. IGCC start up times from cold are slow in comparison to PCC, and can be as high as 24 hours, although times are considerably reduced for hot start-up. These flexibility problems and inability to load follow are increased by the addition of CO<sub>2</sub> capture. However, it is not expected that co-firing biomass or running with 100% biomass would add major problems to the plant's flexibility. In summary, IGCC technology, with or without capture, with coal or biomass, is not suitable for peaking plant operation.

IGCC plants using petroleum residues have availabilities above 90%, and have a favourable business case with the tri-generation of hydrogen, steam and electricity. Operation and maintenance methods have to be optimised by learning from experience, in order to minimise non planned overhauls. These learning curve effects will increase with the increasing total hours of operation of all IGCC plants – however, there is a distinct gap when comparing their total operating hours to those of almost a century of PC combustion. More coal IGCC demonstration projects are probably needed to compete with PCC availability (over 90%). Unless future IGCC projects demonstrate better power plant availability, this parameter may take decades to progress.

There is also a need to develop higher efficiency gas turbines, modified to use low CV syngas. In the current gas turbine technology, the low CV syngas is diluted with nitrogen before combustion in non-premix mode (diluted fuel and air meet in the combustion chamber of the gas turbine). More development is needed to burn syngas as done nowadays for natural gas i.e. in premix mode without dilution with nitrogen (fuel and excess air are mixed before combustion), which could save up to 1%-point in overall plant efficiency.

### ***Implications of changing to high % co-firing/complete conversion***

Direct co-firing of biomass in a coal IGCC plant raises a very similar set of issues as for direct co-firing in pulverised coal boilers, since the main limitations are still the coal mills and burners. Biomass co-milling then co-firing (option 2 as in Section 2.2.1) for both combustion and gasification is currently limited to ~10% of the input coal thermal energy, because of coal mill limitations, despite the literature suggesting a limit nearer 15%<sup>23,24</sup>. Real-world experience at E.ON's Ironbridge plant in the UK shows that 10% co-milling with sawdust is possible, before a significant reduction in the coal mill grinding performance is observed.

To achieve higher biomass percentages, mills suitable for both coal and biomass should be used, or alternatively, separate mills built for different coal and biomass streams (options 3 and 4 as in Section 2.2.1). There are still issues due to potassium chloride (KCl) present in the biomass that have to be solved to avoid fouling and corrosion. Depending on type of biomass, there are some positive and negative impacts of co-firing in a coal IGCC plant. Co-firing could reduce ASU energy requirements and desulphuration plant investment because of the higher amount of oxygen and lower amount of sulfur contained in biomass relative to coal. However, higher biomass moisture contents require more energy to evaporate – this may offset the co-firing advantages to give a neutral impact on plant energy balances and economics.

From a technical point of view, there are no major difficulties that cannot be overcome regarding the conversion of IGCC to 100% biomass. If, for example, the biomass feedstocks considered contain much more water than coal, the plant's heat integration could be designed to minimise heat loss by using waste heat in drying the feedstock. Ash fusion in the entrained flow gasification could be adjusted using additives (e.g. lime) in order to achieve a feedstock fusion temperature suitable for the gasifier temperature, and to also avoid early ash fusion leading to unburned carbon in the produced ash (high carbon conversion).

The fact that biomass contains typically less carbon than coal leads to a lower CO<sub>2</sub> concentrations in the syngas, and so potentially leading to an increased cost of CO<sub>2</sub> capture. Due to the saturation capacity of chemical solvents with increasing pressure, the dependence of absorption capacity on CO<sub>2</sub> partial pressure is marginal for typical high pressure syngas. For physical solvents, this dependence is linear, so there could be an increase in the CO<sub>2</sub> capture energy and cost, although this could be overcome by increasing the gasification pressure or by cooling the solvent.

### ***Commercial plants***

Some examples of existing coal IGCC plants include Puertollano, Spain (320 MW<sub>e</sub>), Buggenum, the Netherlands (250 MW<sub>e</sub>), along with Wabash River (250 MW<sub>e</sub>) and Tampa Electric (250 MW<sub>e</sub>) in USA. The 100MW<sub>e</sub> plants at Coal Water and Pinon Pine in the US are no longer running.

Several new IGCC power plants are also planned to start-up between 2012 and 2017, with power outputs ranging from 125 MW<sub>e</sub> to 900 MW<sub>e</sub>. These projects are mainly located in the USA and the Far East. One important point to note is the significant increase in maximum project scale compared to the current coal IGCC plants in existence today, the largest of which is Uhde's 320MW<sub>e</sub> "ELCOGAS" plant in Puertollano, Spain.

There are also many existing IGCCs using refinery residues, which have generally had more success than coal IGCC due to the easier handling of viscous fuels compared to solid fuels, and also due to hydrogen cogeneration with electricity. Examples include Pernis, the Netherlands (120 MW<sub>e</sub>), Sarlux

(550 MW<sub>e</sub>), ISAB (500 MW<sub>e</sub>) and API (250 MW<sub>e</sub>) in Italy, along with Reno (180 MW<sub>e</sub>), Eldorado (50 MW<sub>e</sub>), Terre Haute (250 MW<sub>e</sub>), Plaquemine (180 MW<sub>e</sub>) and Delaware (240 MW<sub>e</sub>) in the USA.

### ***Equipment scales***

Studies assess the technical and economical feasibility of IGCC with 1,000 MW<sub>e</sub> gross output using standard gas turbine technology<sup>22</sup>, and 1,200 MW<sub>e</sub> gross output using (recently developed) higher efficiency gas turbines<sup>25</sup>. These more advanced gas turbines are available commercially, but not yet deployed widely within the industry. Potentially, IGCC plants could be feasible above 1000 MW<sub>e</sub> gross output, using two gasifier trains, two ASUs, two gas turbines, two heat recovery steam generators and one single steam turbine.

The high capital cost per unit output (£/kW<sub>e</sub>) inherent to very small units will restrict these plants to specific applications, or locations where incentives are favourable. The likely scale for fully commercial coal IGCC plants is thought to be between 250 and 1200 MW<sub>e</sub>.

### ***Technology Readiness Level***

The TRL of coal IGCC could be assessed as at least 8, if not the maximum of 9, even though coal IGCC is less mature than PCC. This is because many IGCC power plants already exist at utility scale, with power outputs ranging from 50 to 550 MW<sub>e</sub> – despite some remaining availability problems.

The TRL in 2020 of the current coal IGCC designs will likely remain at 9. Some new innovative components could appear during the period, for example, oxygen-air separation with Ionic Transport Membranes (ITM) or efficient hydrogen separation membranes. These novel options are considered in more detail within Sections 2.3.8 and 2.3.11 respectively.

### ***UK activities and capabilities***

Currently, there are no IGCC plants in the UK. Therefore, biomass co-firing as for the UK's pulverised coal fleet is not currently possible, nor is the conversion of an existing plant to 100% biomass. However, there are several IGCC projects with capture planned in the UK (see Section 2.3.10); hence UK capabilities and expertise in IGCC are likely to increase significantly before 2020.

### ***Technical and economic characteristics***

#### ***Flexibility and ability to load follow***

Due to the flexibility of the gas turbine, some European power utilities argue that an IGCC plant is potentially easier to control than a pulverized coal plant. However, in most situations, the gasification unit will generally be running continuously, so the producer gas must have an alternative end-use application, or be stored, when the turbine is part-loaded or off<sup>26</sup>.

IGCC plants have the ability to change their output by about 3%/minute, which is slower than most other plants, and start-up times from cold can be up to 24 hours. It has been suggested that IGCC plants co-firing coal and biomass can currently operate down to ~30% of their nominal capacity<sup>27</sup>, which should also apply to dedicated biomass BIGCC. However, other studies suggest that The minimum acceptable part-load for IGCC plants is assumed to be 60% of the full load, due to problems with part-load operation of the steam turbine system (economiser steaming with sliding pressure operation) and increased NO<sub>x</sub> production from the gas turbine<sup>93</sup>.

PCC plants appear more flexible than IGCC plants in terms of only suffering small efficiency losses whilst reducing the plant load, whereas IGCC net efficiencies decrease much more quickly when going from full, nominal load to partial load<sup>27</sup>. At its minimum load, IGCC plant efficiencies can decrease by as much as 15-20% compared to efficiencies at nominal load, whereas as pulverised coal plants might only lose 5-8%.

### ***CO<sub>2</sub> capture rate and efficiency***

The efficiency of existing IGCC plants without capture currently varies between 38 to 44%, depending on gasifier type, on type of coal and especially, the combined cycle efficiency. Dry radiant gasifiers are more efficient than non radiant gasifiers, and lignite contains more water to evaporate than sub-bituminous or bituminous coals.

Combined cycle power generation is highly efficient, and the best-in-class equipment has recently reached electrical efficiencies over 60% from the input gas<sup>28</sup>. If optimised for syngas input, this level of efficiency would enable IGCC to have an overall plant efficiency close to 50%, as the parasitic load of IGCC auxiliaries including cryogenic air separation is around 10 % points.

Overall plant efficiency could increase in the future to exceed 55%<sup>29</sup> with potential improvements in compressors and turbines efficiencies, and the ability of turbines to accept higher inlet temperatures (between 1,430-1,600°C nowadays). Improving cryogenic Air Separation Unit (ASU) in terms of energy demand and cost will also improve efficiency, as would a potential technology break-through in favour of membrane air separation or other less energy intensive technologies.

### ***Environmental emissions performance***

The environmental performance of coal IGCC is high in comparison to standard pulverised coal combustion technologies (PCC):

- Dust emissions are below 10 mg/Nm<sup>3</sup> (50 mg/Nm<sup>3</sup> for PCC)
- Sulphur emissions are around 1 mg/Nm<sup>3</sup> (200 mg/Nm<sup>3</sup> for PCC)
- NO<sub>x</sub> emissions could be less than 25 ppmv @ 15% O<sub>2</sub> and could be even less than 10 ppmv (single digit NO<sub>x</sub> emissions) depending on gas turbine emission performances (while PCC emissions are higher than 100 ppmv)
- Water consumption is low, since almost two-thirds of the plant's power is generated via a gas turbine, which doesn't need cooling water. In comparison, PCC needs ambient temperature water for the steam turbine condensation cycle, and the steam turbine provides all the plant's electrical output

### ***Economics with and without capture***

The current capital cost of coal IGCC without capture is approximately 25% greater than PCC without capture: an IEA study<sup>30</sup> gives an average in OECD countries of 2,586 \$/kW<sub>e</sub> and 2,162 \$/kW<sub>e</sub> respectively for IGCC and PCC without capture, based on 2010 economic conditions. Converting to £ in 2011, this is 1,642 £<sub>2011</sub>/kW<sub>e</sub> and 1,372 £<sub>2011</sub>/kW<sub>e</sub> respectively. These are estimates for generic, early commercial plants based on feasibility studies, which have an accuracy of ±30%, and do not reflect project-specific costs or costs for first large-scale demonstration plant, which are likely higher.



An EPRI study from 2008<sup>31</sup> has slightly higher estimates for both IGCC and PCC capital costs, with IGCC plants without capture at 600MW<sub>e</sub> estimated to cost between 2,500 and 3,750 \$/kW<sub>e</sub> (1,600-2,400 £<sub>2011</sub>/kW<sub>e</sub>) The lowest cost in this EPRI study was for a GE water-quench gasifier, and the highest cost for a Shell gas-quench gasifier. For comparison, the EPRI study also gives the capital cost of a 600MW<sub>e</sub> supercritical PCC plant as between 2,250 and 2,600 \$/kW<sub>e</sub> without capture (1,440-1,670 £<sub>2011</sub>/kW<sub>e</sub>).

The operating costs of a coal IGCC plant without capture are 70 to 90 \$/kW<sub>e</sub>/yr (53 – 68 £<sub>2011</sub>/kW<sub>e</sub>/yr).

The power generation cost, or levelised cost of electricity (LCOE), of IGCC without capture is on average 75 \$/MWh (48 £<sub>2011</sub>/MWh) in the OECD, which is 14% greater than PC combustion without capture (at 66 \$/MWh, or 42 £<sub>2011</sub>/MWh)<sup>30</sup>.

Large-scale fossil fuel power plant capital costs have more than doubled in the seven years from 2000 to 2007, and then fluctuated from 2007 to 2011. They could be subject to further fluctuations depending on the demand for materials and future plant construction prices. However, this is unlikely to significantly modify the relative positions of PCC and IGCC with or without CO<sub>2</sub> capture.

The additional cost of biomass co-firing depends primarily on the biomass fuel cost, which is usually significantly higher than the cost of coal – IEA studies give an average biomass cost for OECD countries of 11.32 \$/GJ compared to 3.6 \$/GJ for coal. The fuel cost accounts for 40% of the total power generation costs for coal IGCC, hence is key sensitivity.

It is expected that the additional capital costs of biomass co-firing will be similar to those for PCC, i.e. based on the large co-firing retrofit schemes in Europe, the capital costs of the biomass storage, handling and co-firing systems are approximately €200 - 400 per kW<sub>e</sub> of co-firing capacity (175 - 350 £<sub>2011</sub>/kW<sub>e</sub>).

---

<sup>21</sup> Furfari S. (2010) "Reconciling International Energy Issues and Sustainable Development", Keynote Lecture, International Conference on Gas Turbine

<sup>22</sup> IEA GHG (2003) "Potential improvements in IGCC with CO<sub>2</sub> capture", Report PH4/19, IEA Greenhouse Gas R&D Programme, Cheltenham, UK.

<sup>23</sup> Perry M. and F. Rosillo-Calle (2006) "Co-firing report-United Kingdom", IEA Task 40

<sup>24</sup> Wils A., Calmano W., Dettmann P., Kaltschmitt M. and H. Ecke (2011) "Reduction of fuel side costs due to biomass co-combustion", Journal of hazardous material

<sup>25</sup> Kanniche M., Gros-Bonnivard R., Jaud P., Valle-Marcos J., J.-M. Amann (2010) "Pre-combustion, post-combustion and oxy-combustion in thermal power plant for CO<sub>2</sub> capture", Applied Thermal Engineering (30)

<sup>26</sup> Dijkema, G.P.J.; Z. Lukszo; A. Verkooijen; L.J. de Vries and M.P.C. Weijnen (2009) "De regelbaarheid van elektriciteitscentrales. een quickscan in opdracht van het ministerie van economische zaken". Technical report, TU Delft, Faculteit Techniek, Bestuur en Management, Delft. Available at:

<http://www.nextgenerationinfrastructures.eu/download.php?field=document&itemID=499787>

<sup>27</sup> Seebregts, A. and J. van Deurzen (2011) "Carbon Capture & Storage in power generation and wind energy: flexibility and reliability issues in scenarios for Northwest Europe" GHGT-10 Energy Procedia 4, 5877–5888

<sup>28</sup> Patel (1 July 2011) "Pushing the 60% Efficiency Gas Turbine Barrier", Power magazine, available at:

[http://www.powermag.com/gas/Pushing-the-60-percent-Efficiency-Gas-Turbine-Barrier\\_3784.html](http://www.powermag.com/gas/Pushing-the-60-percent-Efficiency-Gas-Turbine-Barrier_3784.html)

<sup>29</sup> Wicks R. and M. Keay (2005) "Can Coal Contribute to Sustainable Development?" Energy and Environment, 16 (5) 767-779

<sup>30</sup> Finkenrath M. (2011) "Cost and Performance of Carbon Dioxide Capture from Power Plants", OECD IEA

<sup>31</sup> Booras G., Holt N. and J. Marasigan (2008) "Updated Cost and Performance Estimates for Clean Coal Technologies", EPRI report no. 1014223

### 2.2.3 Dedicated biomass combustion

For most solid fuels, including solid biomass materials, there are three general types of combustion equipment that are employed for applications at domestic, commercial and industrial scales of operation<sup>32</sup>:

- **Grate combustors**, which are generally employed for domestic fires and stoves, and for the small and medium-sized industrial and commercial applications
- **Fluidised bed combustors**, of the bubbling bed (BFB) and circulating bed (CFB) types, which are commonly employed for the medium to large industrial, commercial and utility applications, with the circulating fluidised beds generally being more appropriate at larger scales of operation
- **Pulverised fuel combustors**, which are usually employed for the combustion of coal and other solid fuels for large industrial and utility applications. These are rarely used for 100% biomass firing, and as described above, the principal interest, in the current context, is in the co-firing of biomass materials in existing large coal-fired utility boilers. In recent times, however, there has been some interest in the conversion of existing pulverised coal boilers to 100% biomass firing

In this section only the grate firing and fluidised bed firing of biomass materials in dedicated boilers will be considered.

In **grate-fired systems**, the fuel particles are relatively large, up to 10-50 mm or so, and these are distributed over a moving or static grate, or retort, to form a fuel bed. Some of the combustion air is supplied through the fuel bed from underneath the grate, with the balance being provided above the grate in the form of secondary or overfire air. The normal intention in grate-fired systems is to attempt to retain the majority of the fuel ash on the grate, as it is generated by the progressive combustion of the fuel particles, to be removed either manually or mechanically, to an ash pit. In most systems, however, a significant quantity of the ash will be released from the bed, as fly ash particles entrained in the combustion gases, or in the form of vapours and fine fumes.

In **fluidised bed combustion systems**, the fuel particles, generally up to 10-50 mm or so in size, are suspended in a bed, by a fluidising air stream, along with a relatively coarse-grained bed material. The nominal bed temperatures are generally in the range 750-900°C, depending principally on the ash behaviour. The great majority of the biomass ash leaves fluidised bed combustor furnaces in the form of fly ash particles, generally of up to around 50-100µm in diameter. This material will also contain fine particles of elutriated bed material, which is most commonly quartz sand. If limestone is employed as a bed material for sulphur capture, then unreacted limestone, with lime and calcium sulphate/sulphite may also be present in the fly ash materials. A relatively small portion of the bed material and ash may also be removed periodically through bed drains, located underneath the fluidised bed to help maintain the bed inventory.

The combustion temperatures in fluidised beds are somewhat lower than those that apply in fixed beds. The bed and freeboard temperatures when burning biomass materials tend to be less than 900°C. The ash particles are largely unfused, and tend, in a number of ways, to resemble the ash produced by combustion of the fuel in a laboratory furnace at similar temperatures.

## ***Development aspects and prospects***

### ***Key drivers for development, commercial plants***

Grate fired boilers, bubbling fluidised bed and circulating fluidized bed furnaces and boilers have been widely used for firing solid fuels, including a wide range of biomass materials over a wide range of scales of operation, for many decades. They can be regarded as being fully developed technologies with a large number of plants in operation worldwide, and a number of experienced equipment suppliers. They are used widely to recover energy for the production of heat and electricity from biomass residues in a number of important industries, including pulp and paper manufacture, sugar beet and cane refineries, the production and refining of vegetable oils, starch production and the biofuel industries.

### ***Key development issues***

There are few development issues associated with dedicated biomass combustion technology. With some biomass materials, there may be concerns about high chlorine and alkali metal contents, which can lead to increased risks of excessive ash deposition on boiler surfaces, increased metal wastage rates of high temperature boiler components and of negative impacts on SCR catalyst performance. These risks are minimised by close control of the delivered fuel specification, and, in some cases, the use of fireside additives can be of value.

The developments in grate firing and fluidised bed firing in recent years have largely been associated with the application of these technologies to an ever wider range of fuels and, in the case of CFB combustion and boiler technology, with the increase in boiler plant sizes from industrial scale to the utility scale. Otherwise the developments have been generally incremental in nature, with slow increases in efficiency<sup>33</sup>.

### ***Main player internationally***

There are a large number of equipment suppliers of stoker and fluidised bed fired boiler plants for biomass materials, covering the industrial and utility boiler market across the world. In Europe, the major OEMs for industrial scale biomass boilers include Aalborg Energie, AE&E Group, Aker Kvaerner, B&W Volund, Doosan Power Systems, Foster Wheeler Global Power, Keppel Seghers, Metso Power, Martin Engineering, and Vyncke Energietechnik.

### ***UK activities and capabilities***

There are a small number of medium-large dedicated biomass power plants in operation in the UK in 2011, burning poultry litter, cereals straw and wood fuels.

A substantial number of new build biomass power plant projects at scales of operation from 200 MW<sub>e</sub> up to 350 MW<sub>e</sub> have been announced or are in the planning stage, however it remains to be seen how many are actually built.

Apart from Doosan Babcock who has a bubbling fluidised bed boiler technology, which is normally supplied through Enmas, a licensee company in India, there are no significant British boiler makers active in the market for industrial biomass boilers.

### ***Technology Readiness Level***

As stated above, the combustion of a wide range of biomass materials in dedicated power stations is a fully commercial technology with a large number of plants operating worldwide and a number of experienced suppliers. An overall TRL value of 9 would appear to be appropriate.

### ***Environmental factors***

In general terms, the biomass materials have lower levels of the prescribed pollutant species than most other solid fuels, and the current range of environmental control equipment is capable of flue gas clean-up to the standards set by the regulatory authorities. The experience in biomass combustion in the UK and elsewhere has indicated that there has been little or no evidence of any significant negative environmental impacts on releases to air, water and land associated with these plants.

### ***Technical and economic characteristics***

#### ***Equipment scales***

Industrial biomass power plants based on stokers or fluidised bed boilers are available at all scales of operation relevant to this TESBIC project, i.e. from 10 MW<sub>e</sub> to 450MW<sub>e</sub>.

When determining the scale of a new dedicated biomass power plant, one key trade-off is the decrease in power generation costs when plant scales increase, versus the increase in marginal biomass costs as volumes and transport distances increase. For larger plants to be viable, the economies of scale and efficiency gains need to be higher than the additional biomass purchase and transportation costs. For this reason, most current biomass combustion power plants are scaled at less than 100MW<sub>e</sub> in order to minimise biomass collection and transportation costs<sup>86</sup>. However, several new biomass combustion projects in planning around Europe are at scales of up to 350MW<sub>e</sub>, as international biomass supply chains are now more mature and combustion technology is now seen as a less risky capital investment.

#### ***Flexibility***

The biomass boilers, based on stoker or fluidised bed combustors, have good operational flexibility with relatively short start-up and shutdown times, and good load following capabilities.

#### ***CO<sub>2</sub> and efficiency***

The CO<sub>2</sub> production levels from industrial scale biomass boilers vary widely, but will generally be in excess of 1,000 gCO<sub>2</sub> per kWh power output, i.e. significantly higher than that from pulverised fuel power plants. This is principally because of the lower cycle efficiency of these plants, due to the higher excess air levels in the boiler, the higher unburned carbon levels and the fact that most of the industrial scale power plants will not have reheat. With the low sulphur biomass materials, it is possible to install flue gas heat exchangers and to operate with lower boiler outlet temperatures than is possible with other fuels.

The CO<sub>2</sub> produced by the combustion of biomass materials in dedicated boilers can generally be regarded as being largely renewable in origin, depending on the nature and source of the biomass. There will be a small amount of fossil fuel utilisation in the upstream harvesting, transport and processing of the biomass material, and most biomass combustion plants will use fossil fuels in

modest quantities for start-up and for occasional combustion support, generally when the delivered fuel quality is poor. In many cases, the plants will be firing a residue or waste material from the industrial process, which would under other circumstances be sent for disposal to land. This material is often of poor and variable quality, and hence plant efficiencies can be poor.

As stated above, the thermal and power cycle efficiencies of dedicated biomass power plants vary widely depending on the fuel quality, and on the details of the process, i.e. on the scale of operation and the specific arrangement of the system. In general, the net cycle efficiencies, based on the lower heating value (LHV) of the fuel will be less than 40%. However, many of the large plants being planned in the UK has design efficiencies of up to 39-40%.

### ***Economics***

Again, because of the very wide range of biomass fuels and fuel qualities, and of the large number of industrial applications, it is very difficult to make general comments about the economics of the industrial scale biomass combustion processes.

In the case of new build biomass power plants, the capital costs of new plants in the range 30-50 MW<sub>e</sub>, as indicated by the published costs of the recent biomass power plants built in recent years in the UK are of the order of £2,000-3,000 per kW<sub>e</sub> installed.

In the Biomass CCS Study for IEAGHG<sup>34</sup>, the capital cost estimates ( $\pm 30\%$ ) of the dedicated biomass power plants were as follows:

- €370 million (£<sub>2011</sub> 325 million) or around €1,356 per kW<sub>e</sub> (1,193 £<sub>2011</sub>/kW<sub>e</sub>) for a 300 MW<sub>e</sub> CFB power plant without CCS (Case 3A). This is in the same region as that for the large pulverised fuel power plants
- €185 million (£<sub>2011</sub> 163 million), or around €2,470 per kW<sub>e</sub> (2,173 £<sub>2011</sub>/kW<sub>e</sub>) for a 75 MW<sub>e</sub> BFB power plant without CCS (Case 4A). This is not inconsistent with the estimate for the UK's recent new build dedicated biomass power plants given above

Estimates of the total operating and maintenance costs and levelised cost of electricity (LCOE) for the dedicated biomass power plants are also provided:

- O&M costs = €96/MWh (84 £<sub>2011</sub>/MWh), and LCOE = €120/MWh (106 £<sub>2011</sub>/MWh) for a 300 MW<sub>e</sub> CFB power plant without CCS (Case 3A)
- O&M costs = €125/MWh (110 £<sub>2011</sub>/MWh), and LCOE = €167/MWh (147 £<sub>2011</sub>/MWh) for a 75 MW<sub>e</sub> BFB power plant without CCS (Case 4A)

Overall, however, it is clear that the total O&M costs and the electricity generation costs of biomass power plants are very dependent on the delivered fuel costs, and this depends largely on the nature and source of the biomass fuels.

### ***Feedstocks and feasibility***

A very wide range of biomass and other materials are burned successfully in stoker fires and fluidised bed boilers worldwide. An overview of the influence of the form and particle size of the biomass fuel on the selection of the appropriate combustion technologies is presented in Table 3.

**Table 2.4: Examples of furnace technologies according to the form and particle size of the fuel<sup>35</sup>**

Form	Maximum particle size	Furnace Technology
Bulk material	< 5 mm	Direct-fired furnaces, muffle furnaces, cyclone burners, CFB
Bulk material	< 50 mm	Underfeed stokers, grate firings, BFB, CFB
Bulk material	< 100 mm	Grate firings, BFB
Bulk material	< 500 mm	Grate firings, BFB
Shredded or cut bales	< 50 mm	Direct-fired furnaces, grate firings, BFB, CFB
Bales, sliced bales	Whole bales	Grate firings, cigar burners
Pellets	< 30 mm	Underfeed stokers, BFB, CFB
Briquettes	< 120 mm	Grate firings, BFB

In general terms, grate furnaces are very flexible and can be designed for biomass fuels with high moisture contents, up to around 50-55%, and with varying particle sizes and high ash contents. Wood fuels and other materials in chipped and granular forms can be used, although there may be restrictions on the level of fines in some cases.

Baled materials such as straw, cereals and grass, can be fired in grate systems, however they will need purpose-designed handling, storage, feeding and combustion systems due to their specific physical characteristics.

Fluidised bed combustors can be designed for a wide range of fuel types, although there are normally limitations on the fuel moisture content and particle size distributions, and on the ash content and ash chemistry.

Historically, there have been significant problems with the sintering of the fluidised bed when firing biomass fuels with low ash melting temperatures, however modern BFB furnaces can be designed to operate at low bed temperatures of 650–850°C to burn biomass fuels with low ash-melting temperatures, without sintering problems in the bed. In some cases, fuel additives can be applied to further reduce the risks of operational problems due to bed agglomeration.

<sup>32</sup> The Handbook of biomass combustion and co-firing, ed. S van Loo and J Koppejan, Earthscan 2010.

<sup>33</sup> Jantti T, Sarkki J and Lampenius H. The utilisation of CFB technology for large scale biomass firing power plants, PowerGen Europe 2010, Amsterdam, June 8-10 2010.

<sup>34</sup> IEA Greenhouse Gas R&D Programme, Biomass CCS Study, Report Number:2009/9, November 2009.

<sup>35</sup> Obernberger, I. (1998) "Decentralized Biomass Combustion: State of the Art and Future Development", Biomass and Bioenergy, Vol.14. No.1, pp.33-56

#### 2.2.4 Dedicated biomass gasification

Gasification is a thermo-chemical process in which a solid material containing carbon, such as coal or biomass, is reacted at high temperatures with a limited amount of oxidant, and converted into a gas. The resulting gases mainly contain hydrogen and carbon monoxide, along with nitrogen, water, methane and carbon dioxide, and contaminants such as particulates, tars, sulphur, alkaline and halide compounds. Depending on the level of gas cleaning and conditioning carried out, the cleaned 'syngas' can then be used to produce heat, power or a range of transport fuels and chemicals.

There are several different generic types of gasification technology that have been demonstrated or developed for conversion of biomass feedstocks. Only those gasifier technologies applicable to large-scale power production from solid biomass feedstocks are shown in Table 2.5. The main differences between these are<sup>36</sup>:

- How the biomass is fed into the gasifier and is moved around within it
- Whether oxygen, air or steam is used as an oxidant
- Whether or not the gasifier is operated at above atmospheric pressure
- The temperature range in which the gasifier is operated
- Whether heat is provided by partial biomass combustion in the gasifier (directly heated), or from an external source (indirectly heated), such as circulation of an inert material or steam

These differences, along with the composition of the biomass feedstock, all have a marked impact<sup>37</sup> on the produced gas composition and its calorific value (which can vary between 4-18 MJ/Nm<sup>3</sup>). No gasifier directly produces a gas clean enough for high-efficiency power generation applications – all types require several gas clean up and conditioning steps. However, some gasifier types produce higher quality syngas than others:

- EF: due to the high temperatures, there is very little methane in the syngas, and all tars are cracked within the gasifier to form additional H<sub>2</sub> and CO. Use of pressurised O<sub>2</sub> avoids N<sub>2</sub> dilution
- BFB & CFB: with lower operating temperatures, methane, tars and hydrocarbons are found in the syngas, along with particulates from the attrition of the bed material and ash. Systems can be pressurised or atmospheric, and using pure O<sub>2</sub> avoids N<sub>2</sub> dilution
- Dual: similar to BFB & CFB, but N<sub>2</sub> dilution is always avoided due to the use of steam and indirect heating, plus H<sub>2</sub> and methane generation reactions are promoted

It is worth briefly noting the gasifier types not suitable for large-scale power generation from solid biomass. Downdraft and updraft fixed bed gasifiers have been excluded on the basis of scale, because they cannot generate more than about 1MW<sub>e</sub> and 5MW<sub>e</sub> respectively. Plasma gasifiers could be larger; however, they primarily use waste feedstocks (out of scope) and are focused on waste disposal, not high-efficiency power generation.

**Table 2.5: Large-scale biomass gasifier types<sup>36</sup>**

Note that biomass particles are shown in green, and bed material in blue

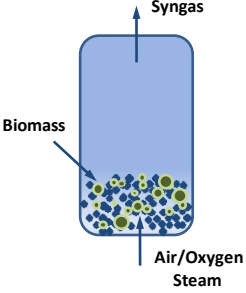
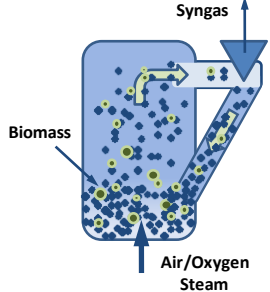
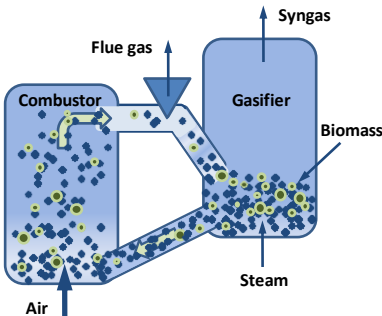
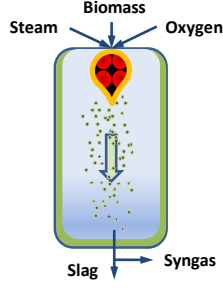
<p><b>Bubbling fluidised bed (BFB)</b></p> <ul style="list-style-type: none"> <li>• A bed of fine inert material sits at the gasifier bottom, with air, oxygen or steam being blown upwards through the bed just fast enough (1-3m/s) to agitate the material</li> <li>• Biomass is fed in from the side, mixes, and combusts or forms syngas which leaves upwards</li> <li>• Operates at temperatures below 900°C to avoid ash melting and sticking. Can be pressurised</li> </ul>	
<p><b>Circulating fluidised bed (CFB)</b></p> <ul style="list-style-type: none"> <li>• A bed of fine inert material has air, oxygen or steam blown upwards through it fast enough (5-10m/s) to suspend material throughout the gasifier</li> <li>• Biomass is fed in from the side, is suspended, and combusts providing heat, or reacts to form syngas</li> <li>• The mixture of syngas and particles are separated using a cyclone, with material returned into the base of the gasifier</li> <li>• Operates at temperatures below 900°C to avoid ash melting and sticking. Can be pressurised</li> </ul>	
<p><b>Dual fluidised bed (Dual)</b></p> <ul style="list-style-type: none"> <li>• This system has two chambers – a gasifier and a combustor</li> <li>• Biomass is fed into the CFB / BFB gasification chamber, and converted to nitrogen-free syngas and char using steam</li> <li>• The char is burnt in air in the CFB / BFB combustion chamber, heating the accompanying bed particles</li> <li>• This hot bed material is then fed back into the gasification chamber, providing the indirect reaction heat</li> <li>• Cyclones remove any CFB chamber syngas or flue gas</li> <li>• Operates at temperatures below 900°C to avoid ash melting and sticking. Can be pressurised</li> </ul>	
<p><b>Entrained flow (EF)</b></p> <ul style="list-style-type: none"> <li>• Powdered biomass is fed into a gasifier with high pressure oxygen and/or steam</li> <li>• A turbulent flame at the top of the gasifier burns some of the biomass, providing large amounts of heat, at high temperature (1,200-1,500°C), for fast conversion of biomass into very high quality syngas</li> <li>• The ash melts onto the gasifier walls, and is discharged as molten slag</li> </ul>	



### ***Biomass gasification power applications***

Syngas is a highly versatile intermediate product, and can be used in numerous different end-use applications, including the production of gaseous fuels (e.g. hydrogen, bioDME, bioSNG), liquid fuels (e.g. BTL, jet, methanol), heat or electricity<sup>38</sup>. Going down the list below, the main options for power generation from syngas increase in average overall electrical efficiency, but also increase in syngas cleanup requirements<sup>39,40</sup>:

- 1) Combustion of the syngas in a **boiler** to raise steam for a steam turbine, driving a generator. Overall electrical efficiency of 20-30%, with minimal gas cleanup required
- 2) Combustion of the syngas in a gas **internal combustion engine (ICE)**, driving a generator. Overall electrical efficiency of 25-30%
- 3) Combustion of the syngas in an **open gas turbine**, driving a generator. Overall electrical efficiency of 30-40%
- 4) Combustion of the syngas in a gas turbine to drive a generator, with exhaust heat recovery raising steam to drive a further steam turbine and generator. Overall electrical efficiency of this biomass integrated gasification combined cycle (**BIGCC**) plant is 40-50%
- 5) Direct electro-chemical conversion of the syngas into electricity across a **fuel cell's** ion-exchange membrane with air. Overall electrical efficiencies above 50% are possible, but extensive gas cleanup is required

Options 1), 2) and 3) are at the early commercial stage for micro- and small-scale heat and CHP applications, with several thousand units installed globally. However, these options have fairly low electrical efficiencies, and as such are not likely to be of interest for CCS applications. Furthermore, at these small scales, air is primarily used as the gasification oxidant (since oxygen separation is too expensive), and hence the syngas is diluted by nitrogen, which effectively prevents the use of pre-combustion CO<sub>2</sub> capture technologies.

Although many biomass gasification processes have been developed, only fluid bed configurations are being considered for applications that generate over 1MW<sub>e</sub><sup>41</sup>. As well as their appropriate scale, fluidised bed gasifiers achieve uniform temperature distribution throughout the bed (thereby producing a gas with constant CV), have high efficiencies, and can cope with varying quality of input material and different feedstocks<sup>42,43</sup>. In contrast, fixed bed gasifiers are only for very small scales, and entrained flow gasifiers have limits in relation to feedstock variability<sup>37</sup>. None of the studies analysed considered entrained flow as a possible technology option; most only focus on a generic atmospheric or pressurised "fluidised" bed technology, with few of the studies actually differentiating between BFB, CFB and Dual fluidised bed technologies.

### ***BIGCC process description***

The Biomass Integrated Gasification Combined Cycle (BIGCC) plant concept contains several components<sup>101</sup>:

- Feedstock preparation: Biomass sizing and drying, and feeding into the gasifier
- Gasification: Partially reacting the biomass feedstock at high temperatures with a controlled amount of air, oxygen and/or steam to create syngas

- Gas cleanup<sup>44</sup>: Series of complex cleanup steps and processes used to clean the syngas from particulates, tars and other contaminants, down to specifications required by the power generation equipment
- Gas conditioning: Optional water gas shift reaction to create H<sub>2</sub> and CO<sub>2</sub> from CO and H<sub>2</sub>O, and optional reforming to create H<sub>2</sub> and CO<sub>2</sub> from CH<sub>4</sub> and H<sub>2</sub>O, with subsequent possible pressurisation. Gas conditioning is usually only carried out when applying pre-combustion CO<sub>2</sub> capture, and not when producing power without capture
- Power generation: Combustion of the syngas in a gas turbine to drive a generator, with heat recovery raising steam to drive a further steam turbine and generator. The exhaust gas discharged from the heat recovery steam generation (HRSG) can be further used for drying biomass feedstock or for supplying heat to other processes<sup>37</sup>

The design for a pressurised air-blown BIGCC plant, without gas conditioning or CO<sub>2</sub> capture, is shown in Figure 2.5.

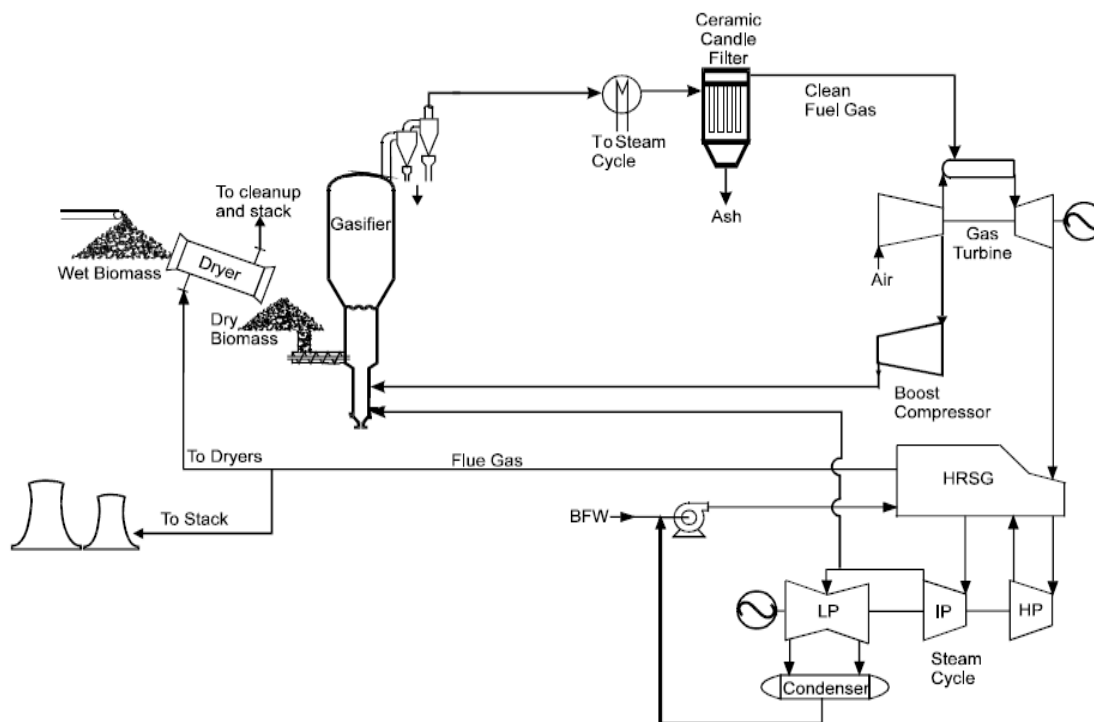

Figure 2.5: Generic schematic of a pressurised BIGCC plant<sup>45</sup>

### ***Choice of BIGCC system operating conditions***

Some of the key tradeoffs involved in designing and commercializing BIGCC systems relate to atmospheric vs. pressurised gasification, hot vs. cold cleanup, the choice of oxidation agent, the adaptability of commercial gas turbines, and the thermal integration between the biomass dryer, gasifier, cleanup equipment, and the turbines<sup>46</sup>.

### ***Atmospheric vs. pressurised gasification***

Atmospheric gasification is simple, flexible, reliable and relatively mature<sup>47</sup>. However, the condensation of tars during gas turbine pre-compression needs to be avoided, hence a cleaning system consisting of a tar cracker, gas cooler, bag house filter and wet scrubber<sup>48</sup>.

Pressurised gasifier systems avoid the energy penalty of downstream gas compression, and allow the use of more efficient hot gas cleanup, and can burn relatively high tars content gas in the gas turbine (since condensation is avoided). Pressurised BIGCC plants have therefore been evaluated by several studies to have higher electrical efficiencies than atmospheric BIGCC systems<sup>91,93</sup>. However, the system is more complex, less flexible, pressurised feedstock mechanisms are needed, and there is much less operational experience available<sup>42</sup>.

#### *Air-blown gasification:*

Using air has been favoured historically for biomass gasification<sup>49,51</sup>, but leads to nitrogen dilution. This gives a low CV syngas (typically 4-7 MJ/Nm<sup>3</sup>), and not only increases the cost of energy recovery and gas cleanup, but also requires modification of the gas turbine by de-rating the firing temperature<sup>50</sup>. Importantly, air-blown concepts are not suitable for pre-combustion CO<sub>2</sub> capture, due to the nitrogen dilution.

#### *Oxygen-blown gasification:*

Using only oxygen avoids nitrogen dilution, and enables smaller gasifier and downstream equipment, but oxygen separation costs are currently high. Plant scales of above approximately 80 MW<sub>e</sub> are thought to be required to justify the addition expense of oxygen separation costs<sup>51</sup>. Although pressurised, O<sub>2</sub>-blown biomass gasifiers are not yet commercial, development activities are ongoing, and interest is increasing for biofuels and hydrogen applications<sup>51,73</sup>.

#### *Steam-blown gasification:*

Indirectly-heated steam-blown gasification with a Dual gasifier avoids both the problems of nitrogen dilution and oxygen separation costs, resulting in a medium CV syngas that is high in hydrogen and methane, and that can readily be used in existing gas turbines<sup>52</sup>.

### ***Development aspects and prospects***

#### ***Drivers for development***

In comparison with conventional combustion of biomass and other biomass gasification power plants, the BIGCC system concept is expected to have several advantages once at commercial scale, including high electrical efficiency, low electricity production costs, and low emissions.

BIGCC is also particularly promising for CCS, since pre-combustion capture technologies offer high capture rates, whilst avoiding some of the plant efficiency losses suffered by other capture technologies. Technically, BIGCC also shares many similarities with coal IGCC, and hence is likely to be able to profit from the experience gained with the first coal IGCC-CCS plants<sup>89</sup>.

#### ***Deployment status, past and future plants***

In the period 1990 to 2005, there was significant global interest in building BIGCC demonstration plants, including the EU's THERMIE programme<sup>37</sup>. During this period, several developers tried to demonstrate BIGCC technology, but with little success<sup>53</sup>:

- The 8MW<sub>e</sub> **ARBRE** plant in Eggborough, UK was based on TPS's atmospheric CFB gasifier<sup>54</sup>, and used locally-grown short rotation coppice willow. The plant was built, but then closed in 2002 during commissioning, because of slagging and tar cracking problems<sup>47</sup>

- Two TPS 15MW<sub>th</sub> atmospheric CFB gasifiers for a boiler and steam turbine were built in Greve in Chianti, Italy in 2002. However, the plant suffered from frequent stoppages due to boiler tube slag accumulation, and a shortage of operating funds, and was only operated intermittently by Ansaldo **Aerimpianti**<sup>55</sup>. A proposed plant conversion to BIGCC never went ahead
- The 350odt/day **FERCO** Dual gasifier was operated at the McNeil site in Burlington, Vermont from 1997, with the syngas successfully co-fired in the wood combustion boiler. Further US DOE funding in support of full BIGCC implementation did not occur, and the plant shut in 2001<sup>56</sup>
- Other projects involving Carbona or TPS included Andhra Pradesh, India (14MW)<sup>57,58</sup>, BIG-GT, Brazil (32 MW<sub>e</sub>)<sup>43</sup>, Biocycle, Denmark/Finland (7 MW<sub>e</sub>)<sup>59</sup> and Bioelettrica, Italy (12MW<sub>e</sub>)<sup>60</sup> were unable to raise sufficient funds, or never began construction

Globally, only one BIGCC early demonstration plant to date has been successfully constructed and operated. The **Växjö Värnamo** project in Sweden<sup>49</sup> was owned by the joint venture Bioflow Ltd, consisting of the technology developer Foster Wheeler and Sydkraft AB (Sweden). The system used a pressurised air-blown CFB gasifier at 18bar with a hot gas filter (as in Figure 2.5), and successfully demonstrated the in-situ use of dolomite catalysts to reduce the tars leaving the gasifier. Starting in 1993, the plant had accumulated more than 8,500 gasification operation hours by its closure in 2000<sup>88</sup>, with the gas turbine running on syngas for more than 3,600 hours, generating 6 MW<sub>e</sub> power and 9 MW<sub>th</sub> heat for district heating. The plant has since only served as a research facility to demonstrate the production of clean syngas suitable for catalytic fuels production (CHRISGAS project).

The EU's FP6 framework also gave €1.7m of funding for the "**BiGPower**" project which ran between 2005 and 2008. This focused on new catalytic tar decomposition, advanced filter media, improved reliability and flexibility of Dual and fixed bed gasifiers, concept assessment for pressurised fluidised bed gasifiers, optimised gas engine performance, design of a biomass gasification with Molten Carbonate Fuel Cell system, and country-specific techno-economic case studies<sup>61</sup>.

Within the last year, there have been a few announcements regarding large-scale BIGCC projects – both of which are planning on using Dual gasifiers:

- **Taylor Biomass Energy (TBE)** has recently started construction of a 20MW<sub>e</sub> BIGCC power plant in Montgomery, New York, US<sup>62</sup>. This plant will be using a mix of MSW, commercial & industrial waste and wood waste, with gasification occurring in three parallel Dual fluidised bed gasifiers<sup>63</sup>. As with Silvagas, the TBE gasifier technology originates from the FERCO demonstration project
- The "**Northwest Florida Renewable Energy Center**" in Port St. Joe, Florida will be developed, owned and operated by Biomass Gas & Electric (BG&E) of Florida<sup>64</sup>. Rentech-SilvaGas are providing the Dual fluidised bed gasifier to this 55 MW<sub>e</sub> BIGCC project, taking in 930 odt/day of woody biomass<sup>65</sup>. Construction is planned to begin in August 2011, with operation in 2013

Despite this very mixed development history, the future importance of high-efficiency biomass power generation is still recognised today. The European Industrial Bioenergy Initiative (EIBI) will support BIGCC as one of its 7 value-chains. The EIBI scheme is proposing to make €20-40m grants available for 1 or 2 demonstration plants from 2013, followed by €150-250m loans for 1 or 2 flagship plants at scales of above 100MW<sub>e</sub><sup>66,67</sup>. Given the construction timescales, this should allow these

demonstration and first commercial plants to be built in the period 2014-2016, allowing early commercial availability of BIGCC by 2020.

The US Department for Energy has also recently launched a new 'Biopower' initiative to accelerate, develop and deploy advanced biopower technologies over the next six years. The initiative is expected to have \$70m of funding in 2011-2012 as part of the department's wider Biomass Program, and will look to support pilot scale projects up to 30 MW<sub>e</sub><sup>68</sup>.

### ***Key development issues***

There are several remaining unsolved technical R&D and development needs that have been highlighted in the literature<sup>69</sup> and other sector reviews<sup>70,71</sup> in order for BIGCC to be successfully demonstrated, and validated at commercial scale. Many of the component technologies in a BIGCC plant are already commercially available at scale, although a few key steps are not yet fully developed. These are discussed in detail below.

#### *Feedstock preparation:*

Many plant stoppages are due to clogging of feeding mechanisms, either due to inhomogeneous feedstock or foreign objects. Blockages are particularly problematic for pressurised systems, which use a pressurised biomass feeding system – this is a technology area where additional development is needed to improve reliability and reduce costs<sup>72,73</sup>.

#### *Biomass gasification:*

Biomass gasifiers are not yet commercial for the large-scale BIGCC power applications considered in this study, but as a result of the considerable R&D and pilot-scale work done during the past 30 years, technologies could be commercialized within a few years with a concerted effort<sup>74</sup>. Further R&D could include work on biomass gasification thermodynamics, gasification behaviour of different types of biomass and utilisation of pre-treated feedstocks (e.g. torrefied biomass).

#### *Gas clean-up (tars):*

Gas clean-up of contaminants is a significant cost<sup>75</sup>, and the most important area where technological advances are needed in order to facilitate the commercialization of biomass gasification systems. Tars have been the most problematic of these contaminants and have been the focus of much attention since the 1970s. Milne et al.<sup>76</sup>, Stevens<sup>77</sup> and Devi et al.<sup>78</sup> provide reviews of issues and literature relating to biomass gasifier tars, their production, their measurement and analysis, their tolerance by end-use devices, and their removal or destruction by in-situ and/or downstream treatments.

To date, standard technology for tar cleaning has proven insufficient for power applications. Water or organic solvent scrubbing R&D has made progress, and there have been recent important advances in hot gas cleanup (thermal and catalytic tar cracking<sup>49</sup>), which is expected to increase overall plant efficiencies by 3-4 %-points compared to cold gas cleanup<sup>88</sup>. In summary, efficient syngas cleanup, and avoidance of tar accumulation has only been recently solved by a few players, and long-term reliability at commercial scale, using real-world syngas, is still to be proven.

#### *Power generation:*

Heat recovery steam generation (HRSG) units and steam turbines are mature technologies, and combined cycle technology is also commercial for natural gas.

However, the utilisation of a gas turbine for low calorific value (CV) gas still requires some modification<sup>37</sup> – the total mass flow through the gas turbine has to increase significantly, compared to a natural gas fired unit, in order to attain the same turbine inlet temperature<sup>79</sup>. This leads to a substantial reduction in the compressor surge margin. The problem can be overcome by de-rating the unit and running it at off-design condition, or installing a new gas turbine designed for the specific producer gas (if available)<sup>79</sup>. Alternatively, indirectly heated or oxygen-blown gasifiers produce a syngas without any nitrogen dilution, and hence with a higher CV, which does not generally require gas turbine de-rating.

The advanced, high-efficiency gas turbines being developed for coal IGCC applications will also be applicable to BIGCC applications – the latest combined cycle turbines have electrical efficiencies of over 60%, and further improvements could enable BIGCC plant efficiencies of over 50% in the future. Further R&D ongoing includes using high efficiency solid oxide fuel cells with biomass gasifiers<sup>51,80</sup> and the effects of possible contaminants present in the gas on advanced conversion devices<sup>81</sup>.

**Table 2.6: Tolerance limits of syngas contaminants<sup>82</sup>**

Contaminant	Turbine	SOFC	Chemicals synthesis
Sulphur, ppmv	20	1 – 0.05	0.2 – 0.01
Halides, ppmv	1	1 – 0.01	0.1 – 0.01
Ammonia, ppmv	-	5,000	10 – 0.02
Sodium + Potassium, ppmw	0.08	-	0.01
Particles (total), ppmw	3.0	-	0
Particles (5-10 µm), ppmw	0.15		
Particles (> 10 µm), ppmw	0- 0.03		
C2-C6, ppmv		2,000	Low

*Project development, engineering, and operation:*

The reasons behind the lack of success for the majority of past BIGCC projects are complex, such as permitting/planning, feedstock supply problems, and slag accumulation in downstream equipment. However, two common themes that need to be recognised and addressed are financial shortages in project execution (sustained investment is required), and developers having unrealistic profit expectations from the first small-scale demonstration plants.

Successful design and operation of BIGCC plants requires further research to optimize the plant scale and operating parameters. The close thermal integration between the biomass dryer, gasifier, cleanup equipment and the turbines is also essential to allow for maximum recovery and use of process waste heat, and ensure high overall plant efficiencies.

**Technology Readiness Level**

Based on the developments in 1999, BIGCC reached the early demonstration stage (TRL 6) with the success of the Värnamo project. However, BIGCC technology has not progressed since this date.

Much of the recent interest and investment in biomass gasification has been on higher-value biofuels applications (such as BTL and bioSNG) instead of large-scale power – however, the biomass gasifiers being used in both cases share many similarities. As a result, several large-scale biomass gasifier developers have in the last decade moved from power and heat applications to focus more on biofuels applications instead. Most of the knowledge and experience gained still exists within the gasifiers developers and research institutions, although may have been diluted by the change in research direction to biofuels applications.

There is also increasing worldwide commercial activity in the gasification of fossil fuels. This BTL and coal IGCC experience and the related cost reductions being accumulated are likely to spill over to BIGCC applications. Due to this ground-work, it is expected that once BIGCC technologies are introduced commercially at large scale, costs and reliability may rapidly mature.

Depending on the success of the EIBI and US DOE programs, plus ongoing industry projects (e.g. Taylor Biomass Energy, Rentech-Silvgas, Air Products), these are likely to prove BIGCC plants can achieve high efficiencies, and significantly improve plant reliability and capital costs. By 2020, BIGCC technology without CCS is likely to have reached TRL 7 or 8. However, it is worth noting that the leading industry project concepts are currently using Dual gasifiers and/or waste feedstocks – which are not best suited to adaptation to BIGCC with CCS.

### ***Global players and UK capabilities***

Since there are very few demonstration plants or system developers, we consider players in each of the BIGCC plant components in turn, before considering the overall combined system<sup>83</sup>:

#### *Feedstock preparation:*

The UK does not have any particularly distinctive capabilities in woody biomass. Globally, numerous large engineering firms supply sizing and drying equipment; e.g. Andritz, Foster Wheeler, Siemens

#### *Gasification:*

The UK has several down-draft and up-draft gasifier developers for small-scale power and CHP applications, but does not have any developers with large-scale (CFB, BFB, Dual or EF) gasifier technology that would be applicable to BIGCC. Furthermore, the UK's academics are only focused on development of small-scale gasification, or modelling of fluidised beds. Large-scale gasifiers that would be suitable for BIGCC are already being developed elsewhere, e.g. in US, Canada, Japan, Sweden, Finland, Germany, Austria and the Netherlands, although mainly for biofuel applications. There are also large-scale biomass gasification research strengths at Northern European and US universities (such as KIT, VTT, Cutec, GTI), along with several large EU projects. Globally, some successful developers and research organisations include<sup>70</sup>:

- BFB: Carbona, GTI, Foster Wheeler, Ebara, Energy Products of Idaho, Enerkem, TRI, ENEA
- CFB: Foster Wheeler, Metso Power, Envirotherm, Uhde, ECN, HoST, VTT, Fraunhofer, VER (Lurgi and TPS no longer active)
- Dual: SilvaGas, Taylor Biomass Energy, Repotec, Chalmers, ECN, TU Denmark
- EF: Choren, Range Fuels, Mitsubishi Heavy Industries, KIT

### *Gas cleanup & conditioning:*

The UK has some capabilities within syngas cleanup, with organisations such as Johnson Matthey working on novel cleaning in EU project “GREENSYNGAS”, APP developing novel plasma cleanup, and ongoing research at Nottingham, Sheffield and Newcastle. However, there are plenty of other experienced groups globally, especially in Northern Europe, such as VTT, Lund, Delft, Munich, FZK, Bologna and ECN. Several large global firms, e.g. Linde, Lurgi, Air Products, Dalhman already offer syngas cleaning equipment.

### *Power generation:*

Globally, the major gas turbine and combined cycle power generation suppliers are GE, Alstom, Siemens, and Westinghouse. In the UK, Siemens Industrial Turbomachinery, based in Lincoln, develop medium CV gas turbines, which are directly relevant to BIGCC applications. Stopford Projects and Leeds University have also done research in the area of waste syngas combustion in gas turbines.

### *Project development, engineering, and operation:*

Although the failed ARBRE project and the UK’s strict planning and emissions permitting regime is known to have put developers off in the past, there is now increasing interest in UK biomass gasification. Although out of scope, this is especially true for wastes to biofuels developers like Ineos Bio and Solena, who are planning large projects in the North-East and London, respectively. Also, Air Products are planning a Westinghouse waste plasma gasification-open gas turbine power plant in Teeside<sup>84</sup>, with the first ever warranty on gas turbine performance with syngas. In the future, the project is also being considered for an AFC Energy fuel cell demonstration with H<sub>2</sub> production<sup>85</sup>.

More generally, the UK’s strengths in biomass co-firing, and the UK’s chemicals industry sector, will ensure relevant engineering skills are available if a new BIGCC plant were to be built in the UK. The UK Government also appears willing to support first-of-a-kind plants in the UK, with significant funding towards Ineos Bio’s feasibility study. Under the Renewables Obligation, dedicated biomass BIGCC plants would also be guaranteed to receive 2 ROCs/MWh<sub>e</sub> (currently ~£100/MWh<sub>e</sub>) as an ‘Advanced Conversion’ technology.

### ***Environmental factors***

The environmental performance of BIGCC is expected to be high in comparison to standard biomass combustion technologies, which have little, if any, significant environmental impacts.

### ***Technical and economic characteristics***

Only a few early demonstration BIGCC plants without CCS have been realised<sup>86,87</sup>, hence BIGCC techno-economic studies<sup>88</sup> analysing different commercial plant configurations are either theoretical, extrapolated from smaller plants or other applications. This results in some uncertainty about the projected techno-economic performance of potential large-scale BIGCC plants<sup>89</sup>.

### ***Equipment scales***

Minimum and maximum scales for commercial BIGCC plants are primarily determined by the type of gasifier, ranging from 2 MW<sub>th</sub> biomass input for atmospheric BFB gasifiers to 2,000 MW<sub>th</sub> for



entrained flow technology, as shown in Figure 2.6. This figure also shows the ETI's definitions of small-scale (10 – 30 MW<sub>e</sub> output) and large-scale (100+ MW<sub>e</sub> output) power applications.

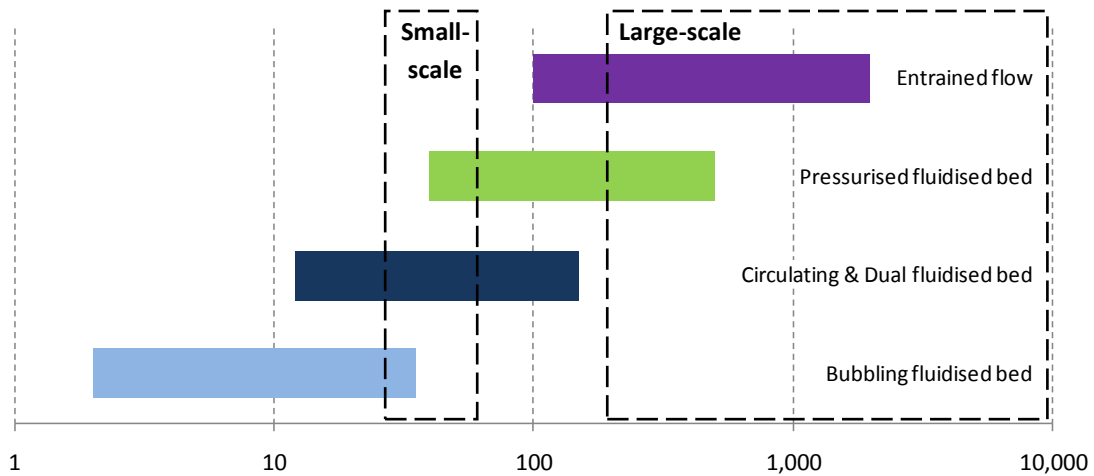

Figure 2.6: Gasifier technology capacities, MW<sub>th</sub> biomass input<sup>36,90</sup>

Atmospheric fluidized bed gasifiers are applicable for small- to medium-scale applications, ranging from 2 to 30 MW<sub>th</sub> input for BFB, and 12 to 150 MW<sub>th</sub> for CFB and Dual gasifiers. Pressurised fluidised bed systems are expected to be commercially viable between 40 and 500 MW<sub>th</sub>, with entrained flow gasifiers suitable for even larger applications between 100 and 2,000 MW<sub>th</sub> input. Gasifiers that operate at higher temperatures and pressures, use smaller particle sizes and avoid nitrogen dilution will have faster reaction rates, and hence be able to effectively process larger biomass flows.

Several studies<sup>91,51,92,93</sup> have found that by increasing BIGCC plant scales, capital cost economies of scale and efficiency gains have a larger benefit than the increased biomass supply costs, for systems ranging from 50 to 900 MW<sub>th</sub> biomass input (i.e. 20 to 450 MW<sub>e</sub>). By comparison, IEA estimates that BIGCC plants will be commercial between 30 and 200 MW<sub>e</sub> output (~75 to 500 MW<sub>th</sub> input)<sup>94</sup>.

### **Efficiency without capture**

The internal power consumption (parasitic load) for a large scale BIGCC plant without CCS is between 11% and 15% of the gross generated electricity<sup>36</sup>.

When comparing BIGCC net system efficiencies to other biomass power generation technologies, even at very small scales (1-20MW<sub>e</sub>), BIGCC is at least 10 %-points more efficient than gasification with ICEs, pyrolysis or direct combustion<sup>41</sup>. The higher theoretical efficiencies for BIGCC compared to other technologies are also confirmed at larger scales by several studies<sup>94</sup>. A review of BIGCC efficiencies is summarized by *Klein et al.* (2011)<sup>89</sup> as shown in Figure 2.7. Theoretical plant LHV efficiencies range from 40% to 50%, with 45% even achievable at small-scales for the most efficient plant designs<sup>91,88,51</sup>. For comparison, IEA give BIGCC efficiencies at ~40% currently, with future designs offering the potential for efficiencies over 50%<sup>95</sup>.

### **Flexibility and ability to load follow**

Dedicated BIGCC plants are not expected to be any more flexible than coal IGCC plants, and may be less flexible depending on the heat integration for feedstock drying.

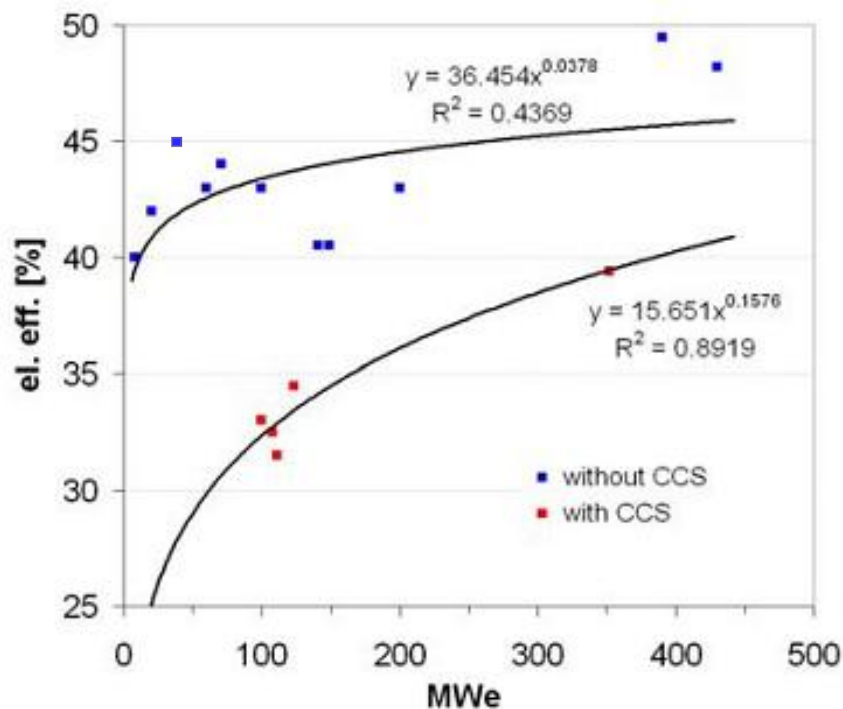

Figure 2.7: BIGCC plant electrical efficiency with and without CCS, obtained from literature<sup>89</sup>

### Capital costs without capture

Capital costs estimates vary depending on specific modelling assumptions, plant configurations, feedstocks, and have also risen significantly in the past decade<sup>96</sup>. However, based on the literature review by Klein *et al.* (2011)<sup>89</sup> and additional reports<sup>47,51,54,49,86,91,94,99,38,100</sup>, costs can be estimated at different plant scales. The capex values for BIGCC without CCS (on the red line given in Figure 2.8) are 1,600 - 2,000 £<sub>2011</sub>/kW<sub>e</sub> for a 100 MW<sub>e</sub> plant, and around 1,200 - 1,300 £<sub>2011</sub>/kW<sub>e</sub> for a 400 MW<sub>e</sub> plant. For comparison, IEA gives a similar range of capital costs of 1,150 - 2,300 £<sub>2011</sub>/kW<sub>e</sub> for future commercial plants (30 - 200 MW<sub>e</sub>).

Figure 2.8 shows the marked effect that plant scale has on capital costs, especially below 100MW<sub>e</sub>. IEA gives considerably higher capital costs of 2,500 to 5,650 £<sub>2011</sub>/kW<sub>e</sub> for smaller scale (5-10MW<sub>e</sub>) demonstration plants<sup>94</sup>. This agrees with Klimantos *et al.* (2009), who state that BIGCC plants are still a long way from achieving the desired capex range of 1,300-1,750 £<sub>2011</sub>/kW<sub>e</sub> necessary to make BIGCC competitive<sup>88</sup>.

As already discussed above, based on the available literature and plants, there is no clear distinction that can be made between the costs of BIGCC systems incorporating Entrained flow, BFB, CFB and Dual fluidised bed gasifiers. A few studies estimate that BIGCC specific capital costs (in terms of £/kW<sub>e</sub>) for pressurised fluidised systems are around 10-15% lower than atmospheric systems<sup>51,88,93</sup>.

In comparison to other dedicated biomass power generation technologies, such as biomass combustion or coal IGCC<sup>97</sup>, BIGCC is currently significantly more expensive<sup>98</sup>. However, BIGCC is expected to have comparable capital costs in the long-term, once the technology and efficiencies are proven at scale.

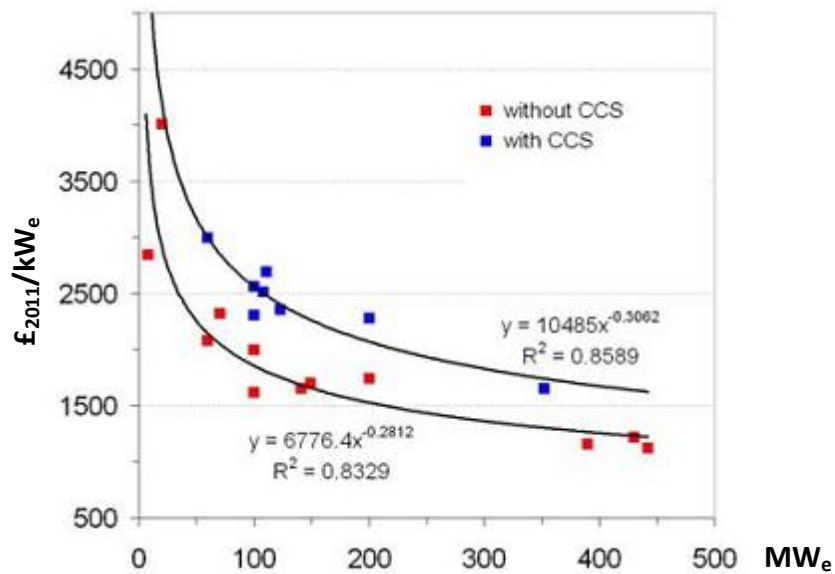

Figure 2.8: BIGCC plant capital costs with and without CCS<sup>89</sup>

### Operating costs

BIGCC plant operational costs can be split into fixed costs (e.g. labour, insurance) and variable costs (e.g. consumables, biomass fuel). Excluding biomass costs, IEA Bioenergy estimates the annual plant opex at about 4% of the total capital costs<sup>94</sup>. This corresponds with the majority of values given by the individual studies considered in this section<sup>49,86,47,54,38,100,99,51</sup>, that indicate values around £35/kW<sub>e</sub>/yr for the fixed operational costs in addition to the biomass fuel costs<sup>51,100</sup>. Only one study, modelling a Dual gasifier, gave significantly higher operational costs at £93/kW<sub>e</sub>/yr<sup>38</sup>.

### Feedstocks and feasibility

As well as the uncertainty about the projected techno-economic performance of potential large-scale BIGCC plants, additional uncertainty also occurs concerning different input raw biomass materials. Most techno-economic BIGCC studies assume wood as the biomass fuel, since it is relatively easy to gasify. However, energy grasses and agricultural residues could also be available in large volumes, but as they contain more ash (which complicates the gasification and gas cleaning processes), these feedstocks are expected to result in lower plant performance. There is scarce information about the effects of these different biomass fuels on the performance of the overall BIGCC process.

### BIGCC with pre-combustion capture

This sub-section includes information regarding the combination of dedicated biomass gasification and carbon capture, in terms the most suitable gasifier types, capture rates, efficiencies and economics with capture. The decision was made not to place this sub-section elsewhere in the report, since the information presented here mainly relates to the different biomass gasifiers and dedicated BIGCC, rather than focusing on the physical absorption capture technology, which is presented later in Section 2.3.10.

Only a few studies consider pre-combustion CO<sub>2</sub> capture for BIGCC power plants<sup>38,89,99,100,101</sup>. However, to date, no BIGCC plants with pre-combustion capture have been built at any scale –

therefore, none of the proposed configurations in these studies can currently be proven to be superior in terms of economic feasibility and technological reliability. A simple process diagram is shown in Figure 2.9.

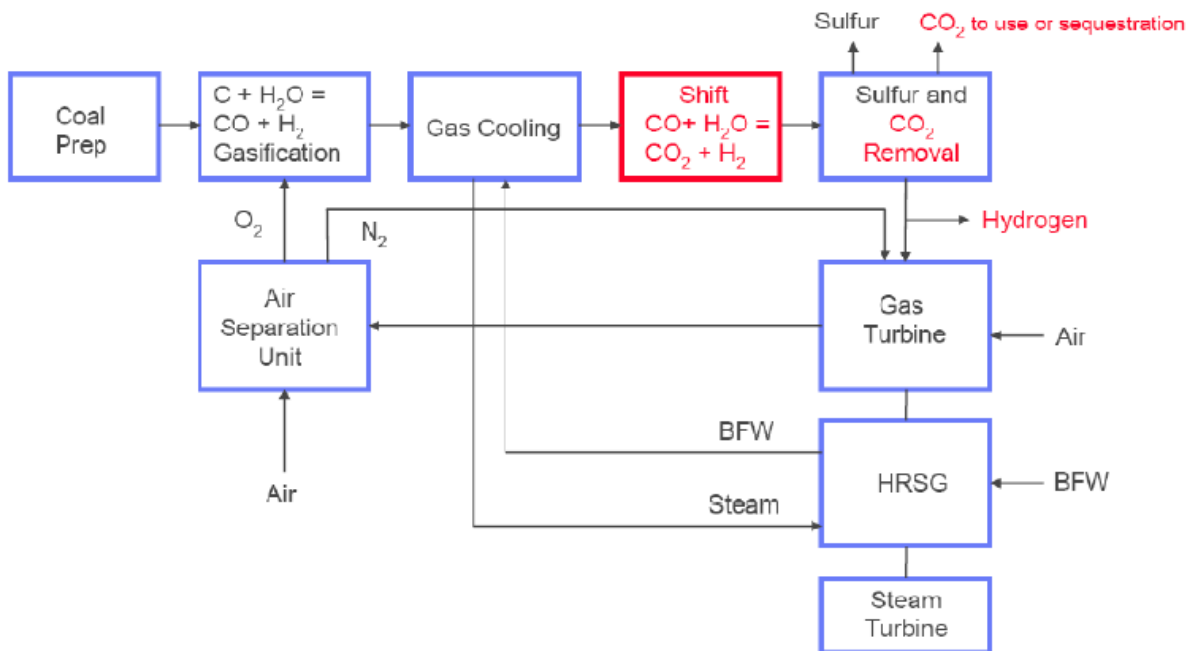

Figure 2.9: IGCC with capture, including WGS reactor<sup>102</sup>

The principal difference between an IGCC plant with and without capture is the presence of a catalytic water-gas-shift reaction, to convert CO in the syngas into CO<sub>2</sub>. The WGS reaction concentrates the carbon species in the syngas into the form of CO<sub>2</sub> that can be subsequently captured in a larger-than-conventional Acid Gas Removal (AGR) system. In this configuration, the AGR unit captures both H<sub>2</sub>S as well as CO<sub>2</sub> by gas-liquid absorption, either using chemical solvents (e.g. MDEA) or physical solvents (e.g. Selexol or Rectisol processes). The resulting hydrogen-rich gas is then used in a combined cycle to generate power<sup>101</sup>.

Syngas dilution with atmospheric nitrogen in air-blown gasification systems eliminates the benefits of pre-combustion CO<sub>2</sub> capture over those of post-combustion capture – i.e. air-blown BIGCC systems would not be used with pre-combustion capture.

Oxygen-blown systems, or indirectly-heated steam-blown systems, on the other hand could effectively leverage pre-combustion separation. Oxygen-blown biomass gasification has been demonstrated and offers higher energy efficiencies and carbon capture rates, although there is less operating experience and economic data available for these systems<sup>38</sup>.

Although Dual gasifiers are indirectly heated, and steam-blown, thereby avoiding nitrogen dilution in the syngas, they have one major shortcoming for BIGCC with capture applications. Because the combustor chamber is air-fired, and has a separate flue gas output, up to 30% of the carbon contained in the input biomass becomes carbon dioxide within this nitrogen rich flue gas<sup>38</sup>. It is assumed that having a smaller post-combustion capture system, in addition to the main pre-combustion capture system, would not be viable, hence the carbon in the combustor flue gas is effectively lost.

Furthermore, whilst Dual gasifiers promote the production of hydrogen, they also promote the production of methane in the syngas (usually between 5 to 15%). This is ideal for BIGCC without CCS, since methane ( $\text{CH}_4$ ) is a highly suitable fuel for a gas turbine. However, for BIGCC with CCS applications, the combustion of this methane in the gas turbine is a further uncaptured loss of carbon from the system. Ideally, a methane reforming reaction needs to happen before the pre-combustion capture, to convert any methane into  $\text{CO}_2$  and  $\text{H}_2$ , but this requires some heat, and imposes an efficiency penalty. The carbon losses for this system configuration (Dual gasifier, WGS, methane reformer, pre-combustion capture, combined cycle) are shown in Figure 2.10.

### ***CO<sub>2</sub> capture rates***

Dual gasifiers are therefore limited to only being able to capture ~55% of the input carbon, provided steam methane reforming (SMR) is used. Although eliminating SMR avoids the 8% carbon loss due to syngas combustion providing heat for the SMR, without SMR, there is less  $\text{CO}_2$  available for capture in the final syngas, and the un-reacted methane results in higher emissions from the gas turbine. A Dual BIGCC-CCS plant configuration without SMR is estimated to only be able to capture ~44% of the input carbon<sup>38</sup>.

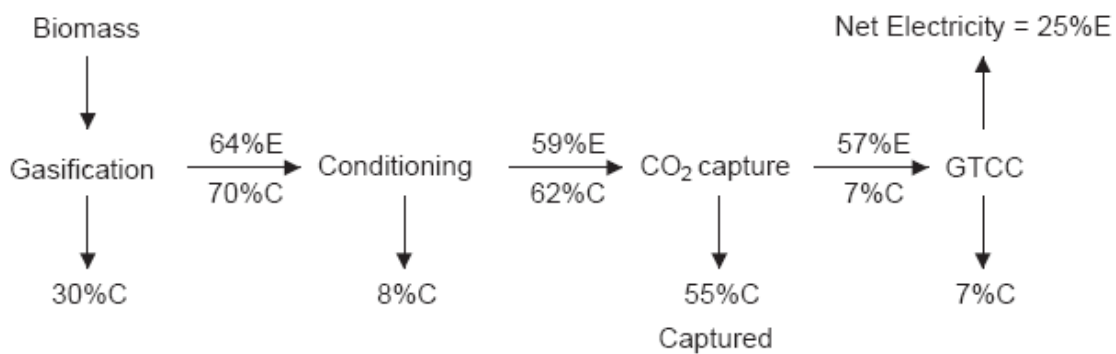

**Figure 2.10: Carbon and energy flows in a Dual BIGCC plant with reforming and capture**

These capture rates of 44% or 55% are significantly lower than the 85-90% achievable for directly-heated BIGCC systems, and are lower than the >60% stated by Klein et al<sup>89</sup> as being the minimum capture rate for BIGCC with CCS to be viable. This low  $\text{CO}_2$  capture rate will significantly increase the emissions from biomass CCS power generation: whilst still carbon negative, a Dual gasifier BIGCC plant with CCS will have a significantly less negative emissions factor ( $\text{gCO}_2/\text{kWh}$ ), and higher cost of avoided  $\text{CO}_2$  (£/ $\text{tCO}_2$ ), compared to  $\text{O}_2$ -blown BIGCC with CCS.

In summary, whilst pressurised  $\text{O}_2$ -blown fluidised bed and entrained flow gasifiers would be most suitable for biomass CCS applications, Dual fluidised beds are most suitable for BIGCC without capture (especially at smaller scales) and are currently the only gasifiers being developed for BIGCC applications.

### ***Efficiency with capture***

Adding pre-combustion capture to a BIGCC plant reduces the overall plant efficiency shown in Figure 2.7. For BIGCC plants in the  $100\text{MW}_e$  range, the net electrical efficiency drops from around 43% without CCS to 33-34% with CCS. However, this efficiency loss decreases with increasing plant scale – at  $400\text{MW}_e$ , the difference in efficiencies is only around 6%.

Based on the literature review of *Klein et al.*<sup>89</sup>, the capture parasitic load is on average between 6 and 10 %-points. This matches with the energy penalty of 8% used by Audus and Freund<sup>103</sup>, and the current state-of-the-art loss of 7 – 9 %-points given for coal IGCC in Florin and Fennell<sup>104</sup>. 2020 targets for coal IGCC are a loss of only 5 to 6 %-points.

### **Capital costs with capture**

The capex values for BIGCC with CCS (on the blue line given in Figure 2.8) are 2,400 - 2,800 £<sub>2010</sub>/kW<sub>e</sub> for a 100 MW<sub>e</sub> plant, and around 1,600 - 1,800 £<sub>2010</sub>/kW<sub>e</sub> for a 400 MW<sub>e</sub> plant.

In comparison to a BIGCC plant without CCS, the additional need for a WGS reactor and the CO<sub>2</sub> absorption system, and the reduced overall efficiency, will increase the specific capital cost of BIGCC with CCS by 35 to 40%, as illustrated in Figure 2.8. This agrees fairly well with the average 44% capex increase for coal IGCC with and without CCS<sup>30</sup>.

- 
- <sup>36</sup> E4tech (2009) "Review of Technologies for Gasification of Biomass and Wastes", report for the NNFC, available at: <http://www.nnfcc.co.uk/tools/review-of-technologies-for-gasification-of-biomass-and-wastes-nnfcc-09-008>
- <sup>37</sup> Pang, S. and J. Li (2006) "BIGCC system for New Zealand: an overview and perspective" *New Zealand Journal of Forestry*, 51 (2), pp. 7-12. Available at: [http://ir.canterbury.ac.nz/bitstream/10092/166/1/12603290\\_Main.pdf](http://ir.canterbury.ac.nz/bitstream/10092/166/1/12603290_Main.pdf)
- <sup>38</sup> Rhodes, J.S. and D.W. Keith (2005) "Engineering economic analysis of biomass IGCC with carbon capture and storage" *Biomass and Bioenergy* 29, 440-450
- <sup>39</sup> Valler, K., Wopera, A., Palotas, A.B. and K.J. Whitty (2009) "NOx formation by Synthesis Gas – Natural Gas Co-firing", Available at: [http://combustion.org.uk/ECM\\_2009/P810158.pdf](http://combustion.org.uk/ECM_2009/P810158.pdf)
- <sup>40</sup> World of Renewables (2010) "Cogeneration Combined Cycle", Available at: <http://www.worldofrenewables.com/page.php?pageid=11>
- <sup>41</sup> Bridgwater, A.V., Toft, A.J. and Brammer, J.G. (2002). "A techno-economic comparison of power production by biomass fast pyrolysis with gasification and combustion". *Renewable and Sustainable Energy Reviews* 6: 181-248
- <sup>42</sup> Wang, L., Weller, C.L., Jones, D.D. and M.A. Hanna (2008) "Contemporary issues in thermal gasification of biomass and its application to electricity and fuel production" *Biomass & Bioenergy*, 32, 573-581
- <sup>43</sup> Waldheim, L. and E. Carpentieri (1998) "Update on the progress of Brazilian wood BIG-GT demonstration project" Technical report, TPS Termiska Processer AB, Sweden and Companhia Hidro Elétrica do São Francisco
- <sup>44</sup> Babu, S. (2008) "Synthesis Gas from Biomass Gasification and its Utility for Biofuels" Technology report for IEA Bioenergy Task 33
- <sup>45</sup> Craig, K. R. and M. K. Mann (1996) "Cost and Performance Analysis of Biomass-Based Integrated Gasification Combined-Cycle (BIGCC) Power Systems" report for NREL/TP-430-21657
- <sup>46</sup> Consonni S. and E.D. Larson (1996) "Biomass-gasifier/aeroderivative gas turbine combined cycles: part a – technologies and performance modeling and part b – performance calculations and economic assessment" *Journal of Engineering for Gas Turbine and Power*, 118, 507–25
- <sup>47</sup> Piterou, A., Shackley, S. and P. Upham (2008) "Project ARBRE: Lessons for bio-energy developers and policy-makers" *Energy policy* 36: 2044-2050
- <sup>48</sup> Bridgwater, A.V. (1995) "The technical and economic feasibility of biomass gasification for power generation" *Fuel* Vol. 74, No. 5:631-653
- <sup>49</sup> Ståhl, K., Waldheim, L., Morris, M., Johnsson, U. and L. Gårdmark (2004) "Biomass IGCC at Värnamo, Sweden – Past and Future", *GCEP Energy Workshop, April 27, Frances C. Arrillaga Alumni Center, Stanford University, CA, USA*
- <sup>50</sup> DeLong M.M. (2005) "Economic development through biomass system integration: summary report". NREL/TP-430-20517, National Renewable Energy Laboratory
- <sup>51</sup> Jin, H., Larson, E.D. and F.E. Celik (2009) "Performance and cost analysis of future, commercially mature gasification-based electric power generation from switchgrass". *Biofuels, Bioproducts & Biorefining* 3: 142-173
- <sup>52</sup> Pellegrini, L. P., Júnior S. de O. and J.C. Burbano (2010) "Supercritical steam cycles and biomass integrated gasification combined cycles for sugarcane mills", *Energy* 35, 1172–1180

- 
- <sup>53</sup> Kwant, K.W. and H. Knoef (2004) "Status of Gasification in countries participating in the IEA and GasNet activity" Novem and BTG, Netherlands
- <sup>54</sup> Pitcher, K., Hilton, B. and H. Lundberg (1998) "The ARBRE Project: progress achieved", *Biomass & Bioenergy* 15 (3) 213–218
- <sup>55</sup> Granatstein, D. L. (2003) "Case Study on waste-fuelled gasification project: Greve in Chianti, Italy" for IEA Bioenergy agreement – Task 36, available at: <http://media.godashboard.com/gti/IEA/GreveCaseStudy.pdf>
- <sup>56</sup> Cain, J. (2009) "BIOMASS ELECTRIC FACILITY IN TALLAHASSEE: HISTORY OF BIOMASS DEVELOPMENT IN BURLINGTON VERMONT" Chair: Committee on Public Affairs, Tallahassee Scientific Society
- <sup>57</sup> Patel, J and K. Salo (2007) "CARBONA BIOMASS GASIFICATION TECHNOLOGY", available at: <http://www.tappi.org/content/Events/07renew/07ren07.pdf>
- <sup>58</sup> Patel, J.; and K. Salo (2004) "Demonstration of new gasification technology" In Proceedings of the Second World Biomass Conference, Biomass for Energy, Industry and Climate Protection held in Rome, Italy, 10-14 May 2004. Vol. 1 p44-47
- <sup>59</sup> Salo, K. (1998) "Kotka Ecopower IGCC-Project, the attempt to transfer the Biocycle project to Finland" *Biomass and Bioenergy* Vol.15, No.3, pp.225-228
- <sup>60</sup> Andritz (2011) "Biomass gasifier for fossil fuel replacement" available at: <http://www.andritz.com/ANONID1858D29D18E8406E/gasification>
- <sup>61</sup> Kurkela, E. & M. Kurkela (2009) "Advanced Biomass Gasification for High-Efficiency Power Publishable Final Activity Report of BiGPower Project", available at: <http://www.vtt.fi/inf/pdf/tiedotteet/2009/T2511.pdf>
- <sup>62</sup> Waste Management World (2011) "Biomass Gasification Project Underway in Montgomery, New York", available at: [http://www.waste-management-world.com/index/display/article-display/5799787322/articles/waste-management-world/waste-to-energy/2011/03/Biomass\\_Gasification\\_Project\\_Underway\\_in\\_Montgomery\\_New\\_York.html](http://www.waste-management-world.com/index/display/article-display/5799787322/articles/waste-management-world/waste-to-energy/2011/03/Biomass_Gasification_Project_Underway_in_Montgomery_New_York.html)
- <sup>63</sup> Taylor Biomass Energy (2011) "The Montgomery Project", available at: [http://www.taylorbiomassenergy.com/taylorbiomass04\\_mont\\_mn.html](http://www.taylorbiomassenergy.com/taylorbiomass04_mont_mn.html)
- <sup>64</sup> Biomass Gas & Electric (2011) "Port St. Joe, Florida", available at: <http://www.biggreenenergy.com/Default.aspx?tabid=4314>
- <sup>65</sup> Rentech (2011) "Port St. Joe Project", available at: <http://www.rentechinc.com/portStJoe.php>
- <sup>66</sup> EIBI (2011) "European Industrial Bioenergy Initiative (EIBI)" available at: <http://www.biofuelstp.eu/eibi.html>
- <sup>67</sup> EIBI (2010) "Implementation Plan 2010-2012", available at: [http://ec.europa.eu/energy/technology/initiatives/doc/implementation\\_plan\\_2010\\_2012\\_eii\\_bioenergy.pdf](http://ec.europa.eu/energy/technology/initiatives/doc/implementation_plan_2010_2012_eii_bioenergy.pdf)
- <sup>68</sup> McCann, L. (2010) "Biomass R&D Technical Advisory Committee DOE Overview" meeting presentations from the September 29-30, 2010, Biomass Research and Development Technical Advisory Committee Meeting, available at: [http://www.usbiomassboard.gov/pdfs/doe\\_overview\\_9.29\\_10\\_final.pdf](http://www.usbiomassboard.gov/pdfs/doe_overview_9.29_10_final.pdf)
- <sup>69</sup> Bhattacharya, A., Manna, D., Paul, B. and A. Datta (2011) "Biomass integrated gasification combined cycle power generation with supplementary biomass firing: Energy and exergy based performance analysis" *Energy* 36, pp. 2599-2610
- <sup>70</sup> E4tech (2010) "Biomass Gasification Review" final report for the Carbon Trust
- <sup>71</sup> U.S. Department of Energy's Office of Energy Efficiency and Renewable Energy (2010) "Biopower Technical Strategy Workshop: Summary Report", available at: [http://www1.eere.energy.gov/biomass/pdfs/biopower\\_workshop\\_report\\_december\\_2010.pdf](http://www1.eere.energy.gov/biomass/pdfs/biopower_workshop_report_december_2010.pdf)
- <sup>72</sup> Wilen C and Rautalin A, (1993) "Handling and feeding of biomass to pressurized reactors: safety engineering" *Bioresource Tech* 46, 77–85
- <sup>73</sup> Lau, F.S., Bowen, D.A., Dihu, R., Doong, S., Hughes, E.E., Remick, R., Slimane, R., Turn, S.Q. and R. Zabransky (2003) "Techno-economic analysis of hydrogen production by gasification of biomass", Final technical report for US DOE, Gas Technology Institute, Des Plaines, IL
- <sup>74</sup> Larson, E.D., Jin, H. and F.E. Celik (2009) "Large-scale gasification-based coproduction of fuels and electricity from switchgrass" *Biofuels, Bioproducts & Biorefining* 3: 174–194
- <sup>75</sup> Maniatis, K. (2001) "Progress in biomass gasification: an overview" European Commission; Innovation and technological development in energy, available at: [http://europa.eu.int/comm/energy/res/sectors/bioenergy\\_publications\\_en.htm](http://europa.eu.int/comm/energy/res/sectors/bioenergy_publications_en.htm)
- <sup>76</sup> Milne T.A., Evans R.J. and N. Abatzoglou, (1998) "Biomass gasifier 'tars': their nature, formation, and conversion" National Renewable Energy Laboratory, Golden, CO
- <sup>77</sup> Stevens D.J. (2001) "Hot gas conditioning: recent progress with larger-scale biomass gasification systems" NREL/SR-510-29952, National Renewable Energy Laboratory
- <sup>78</sup> Devi, L., Ptasiński, K.J. and F.J.J.G. Janssen (2003) "A review of the primary measures for tar elimination in biomass gasification processes" *Biomass & Bioenergy* 24: 125–140
- <sup>79</sup> Rodrigues, M., Walter, A. and A. Faaij (2007) "Performance evaluation of atmospheric biomass integrated gasifier combined cycle systems under different strategies for the use of low calorific gases" *Energy Conversion and Management*, 48, 1289-1301
- <sup>80</sup> Galeno, G., Minutillo, M. and A. Perna (2011) "From waste to electricity through integrated plasma gasification/fuel cell (IPGFC) system" *Int. Journal Hydrogen Energy* 36, 1692-1701
- <sup>81</sup> Baratieri, M., Baggio, P., Bosioc, B., Grigianteb, M. and G.A. Longo (2009) "The use of biomass syngas in IC engines and CCGT plants: A comparative analysis" *Applied Thermal Engineering* 229, 3309-3318

- 
- <sup>82</sup> Bain, R. L. and D.C. Dayton (2005) "Syngas Cleanup and Conditioning in Integrated Biomass Gasification Fuel Synthesis Processes", IEA Task 33 Fall 2005 Meeting, 26-28 September, Innsbruck, Austria, available at: <http://media.godashboard.com/gti/IEA/Fall05AustriaTaskMeeting/IEAInnsATMin1105.pdf>
- <sup>83</sup> E4tech (2011) "Biomass power generation", Combustion and gasification Technology Innovation Needs Assessment (TINA), analysis of future deployment, cost reductions and value to the UK for the Carbon Trust
- <sup>84</sup> Air Products (2010) "Tees Vally Renewable Energy Facility" available at: [http://www.airproducts.co.uk/teesvalley/PDF/Tees-Valley\\_Renewable\\_Energy\\_Facility.pdf](http://www.airproducts.co.uk/teesvalley/PDF/Tees-Valley_Renewable_Energy_Facility.pdf)
- <sup>85</sup> Air Products (2010) "Air Products announces plans for renewable energy plant in Tees Valley" available at: <http://www.airproducts.co.uk/news/2010-07-20.htm>
- <sup>86</sup> Brown, D., Gassner, M., Fuchino, T. and F. Maréchal (2009) "Thermo-economic analysis for the optimal conceptual design of biomass gasification energy conversion systems" Applied Thermal Engineering 29, 2137-2152
- <sup>87</sup> Faaij, A. (2006) "Bio-energy in Europe: changing technology choices" Energy Policy, 34(3):322 – 342
- <sup>88</sup> Klimantos, P., Koukouzas, N., Katsiadakis, A. and E. Kakaras (2009) "Air-blown biomass gasification combined cycles (BGCC): System analysis and economic assessment" Energy 34, 708–714
- <sup>89</sup> Klein, D., Bauer, N., Bodirsky, B., Dietrich J.P. and Popp, A. (2011) "Bio-IGCC with CCS as a long-term mitigation option in a coupled energy-system and land-use model" Energy Procedia 4: 2933-2940
- <sup>90</sup> Waldheim L. and E. Carpentieri (2001) "Update on the progress of the Brazilian wood BIG-GT demonstration project" J Eng Gas Turb Power 123: 525–536
- <sup>91</sup> Schmidt, J., Leduc, S., Dotzauer, E., Kindermann, G. And Schmid, E. (2010) "Cost-effective CO<sub>2</sub> emission reduction through heat, power and biofuel production from woody biomass: A spatially explicit comparison of conversion technologies" Applied Energy 87: 2128-2141
- <sup>92</sup> Larson, E.D., Jin, H. and F.E. Celik (2005) "Gasification-Based fuels and electricity production from biomass, without and with Carbon Capture and Storage" Available at: <https://www.princeton.edu/pei/energy/publications/texts/LarsonJinCelik-Biofuels-October-2005.pdf>
- <sup>93</sup> Marbe, A., Harvey, S. and T. Berntsson (2004) "Biofuel gasification combined heat and power—new implementation opportunities resulting from combined supply of process steam and district heating" Energy 29: 1117-1137
- <sup>94</sup> IEA (2009) "Bioenergy – a Sustainable and Reliable Energy Source: Main report" Available at: <http://www.ieabioenergy.com/LibItem.aspx?id=6479>
- <sup>95</sup> IEA (2008) "Energy Technologies Perspectives" Table 9.1
- <sup>96</sup> IHS Cambridge Energy Research Associates, accessed 20<sup>th</sup> May 2011, available at: <http://www.ihsindexes.com/> Note that according to the North American power capital cost index (PCCI), capital costs given in USD \$<sub>2005</sub> are directly equivalent to GBP £<sub>2011</sub> (i.e. 1.58 capex ratio between 2005 and 2011, but 0.635 currency exchange between USD and GBP)
- <sup>97</sup> Finkenrath M. (2011) "Cost and Performance of Carbon Dioxide Capture from Power Plants" IEA Working Paper
- <sup>98</sup> Caputo, A. C., Palumbo, M., Pelagagge, P. M. and F. Scacchia (2005) "Economics of biomass energy utilization in combustion and gasification plants: effects of logistic variables", Biomass & Bioenergy 28, 35-51
- <sup>99</sup> Larson, E. D. and H. Jin (2006) "Hydrogen and electricity from biomass with and without CCS" Fifth Annual Conference on Carbon Capture & Sequestration, Alexandria, Virginia, USA
- <sup>100</sup> Uddin, S. N. and L. Barreto (2007) "Biomass-fired cogeneration systems with CO<sub>2</sub> capture and storage. Renewable Energy", 32, 1006–1019
- <sup>101</sup> Cormos, C.-C., Padurean, A. and P. S. Agachi (2011) "Technical evaluations of carbon capture options for power generation from coal and biomass based on integrated gasification combined cycle scheme" Energy Procedia 4, 1861-1868
- <sup>102</sup> Snape, C. (2011) "Gasification with CO<sub>2</sub> capture for GREEN hydrogen production", available at: [http://climate-change-solutions.co.uk/pictures/content701/ws\\_3\\_-\\_colin\\_snape\\_igcc\\_fuel\\_cell\\_soc\\_0311.pdf](http://climate-change-solutions.co.uk/pictures/content701/ws_3_-_colin_snape_igcc_fuel_cell_soc_0311.pdf)
- <sup>103</sup> Audus, H. and Freund, P. (2004). "Climate change mitigation by biomass gasification combined with CO<sub>2</sub> capture and storage". IEA Greenhouse Gas R&D Programme, Cheltenham.
- <sup>104</sup> Florin, N. and P. Fennell (2010) "Carbon capture technology: future fossil fuel use and mitigating climate change" Grantham Institute for Climate Change, Briefing paper no. 3



### 2.3 Carbon capture technologies

Several different carbon capture technologies have been considered in this study. These vary enormously in their applicable scales, development status, performance and economics. The following section provides a detailed analysis, based on the types of collected information as given in Section 2.1, for each of the following technologies:

#### ***Post-combustion***

- Solvent scrubbing, e.g. MEA, KS-1, MDEA, chilled ammonia
- Low-temperature solid sorbents, e.g. supported amines, activated carbon, MOFs
- Ionic liquids
- Enzymes
- Membrane separation of CO<sub>2</sub> from flue gas
- High-temperature solid sorbents, e.g. carbonate looping

#### ***Oxy-combustion***

- Oxy-fuel boiler with cryogenic O<sub>2</sub> separation from air
- Ion-exchange membrane separation of O<sub>2</sub> from air
- Chemical-looping-combustion using solid oxygen carriers

#### ***Pre-combustion***

- Integrated gasification combined cycle with physical absorption
- Membrane separation of H<sub>2</sub> from syngas
- Sorbent enhanced reforming using carbonate looping, including the ZECA concept

### 2.3.1 Post-combustion capture: Solvent scrubbing

Post-combustion<sup>105,106</sup> CO<sub>2</sub> capture technology removes CO<sub>2</sub> from the flue gases, and is applicable to any combustion process, including conventional gas, oil and coal-fired boilers, and gas turbines. An overview flow diagram for a conventional coal power plant with post-combustion solvent scrubbing using organic amines is presented in Figure 2.11.

One of the key issues is that oxygen, and the residual NO<sub>x</sub> and SO<sub>x</sub> in the flue gases can react with the solvent at the temperatures that apply in the scrubbing unit to form a range of degradation products and stable, non-regenerable salts. Post-combustion CO<sub>2</sub> capture systems using organic amines on coal fired power plants therefore requires high efficiency upstream particulate collection, NO<sub>x</sub> reduction and flue gas desulphurisation prior to entry to the CO<sub>2</sub> scrubber system.

After the scrubber, the loaded solvent is heated in a separate solvent regeneration or stripper unit to recover the CO<sub>2</sub> for further processing, and to regenerate the solvent.

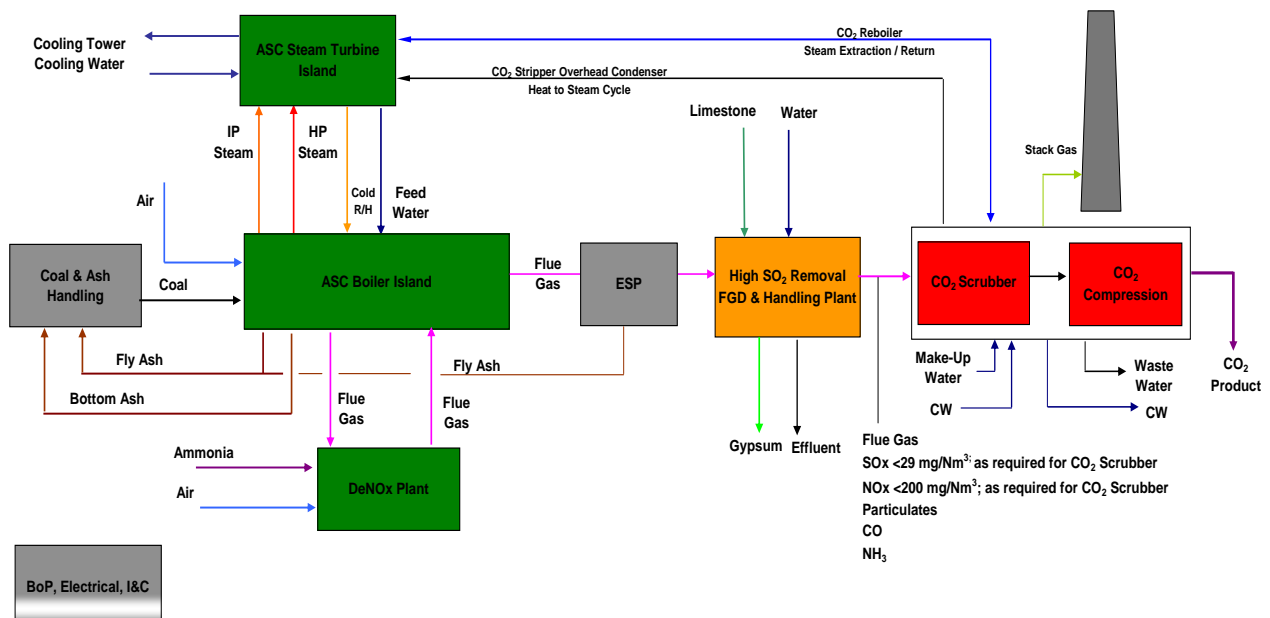
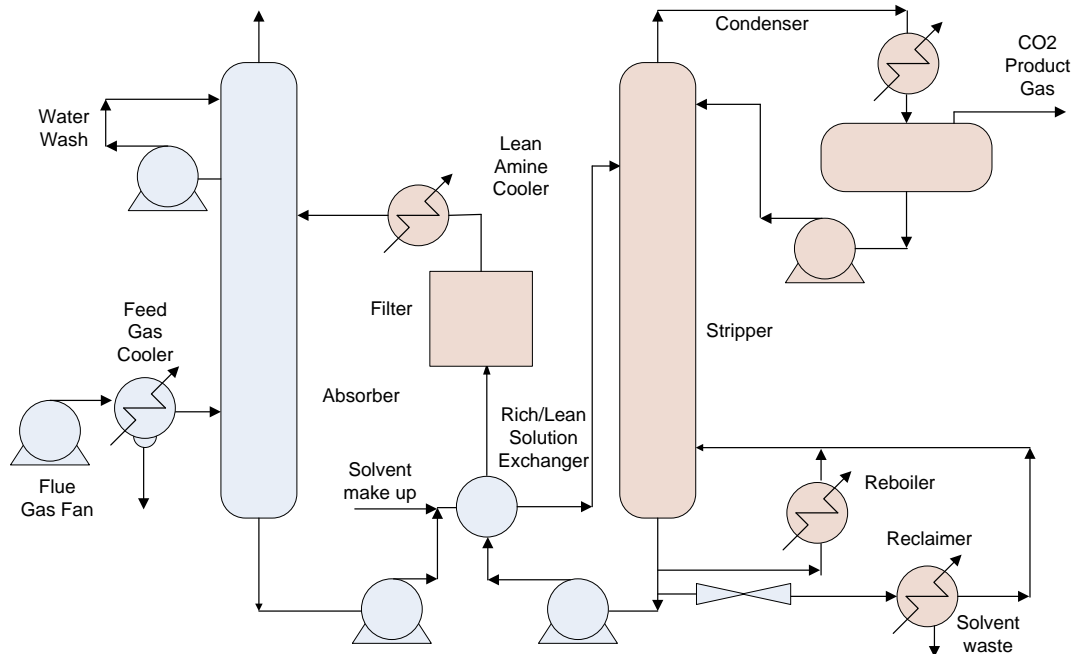

Figure 2.11: Post-combustion CO<sub>2</sub> capture<sup>107, 108</sup>

*Amine scrubbing technology for CO<sub>2</sub> recovery<sup>109</sup>:*

The outline schematic flow diagram of a commercial system for the solvent absorption process in post combustion capture is illustrated in Figure 2.12. The combustion flue gas from the boiler, after suitable flue gas cleaning to remove entrained particulate material and the oxides of nitrogen and sulphur, is cooled and brought into contact with the aqueous amine solution in the absorber tower, at temperatures typically in the range 40–60°C. The CO<sub>2</sub> is absorbed by the chemical solvent as it passes up through the packed tower, and the cleaned gas is then washed with water to remove solvent droplets or vapour carry over. The cleaned flue gas then, leaves the absorber, and is sent for further processing or is exhausted to the atmosphere<sup>105</sup>.



**Figure 2.12: Chemical absorption process for post combustion CO<sub>2</sub> capture<sup>105</sup>**

The 'rich' solvent, containing the chemically-bound CO<sub>2</sub>, is then pumped to the stripper or regeneration vessel, via a heat exchanger. The regeneration of the chemical solvent is carried out in the stripper at elevated temperatures (100-140°C) and at close to atmospheric pressure. The CO<sub>2</sub> product gas leaves the stripper via the condenser, for further processing.

The 'lean' solvent is pumped back to the absorber tower via the lean/rich amine heat exchanger and a further lean amine cooler to bring it to the absorber temperature level.

One of the key process parameters that can determine the economic operation of the solvent scrubbing processes is the energy requirement, which is principally associated with the heat required to regenerate the amine. This is drawn from the power plant steam cycle, and significantly reduces the net cycle efficiency of the power plant.

Amine scrubbing systems have been used for more than 60 years for the removal of hydrogen sulphide and CO<sub>2</sub> from hydrocarbon streams. The application to the scrubbing of CO<sub>2</sub> from the flue gases is much more recent, and this application presents an important set of new challenges to the amine scrubbing technology.

The solvent that has been most frequently used for CO<sub>2</sub> capture is monoethanolamine (MEA), an simple alkanolamine compound. MEA has been preferred because it has a number of advantages over other commercial alkanolamines. These include:

- Relatively high reactivity
- Low solvent cost
- Low molecular weight and hence high absorbing capacity on a mass basis
- Reasonable thermal stability and thermal degradation rate

## ***Development aspects and prospects***

### ***Key development issues and drivers***

One of the key problem areas with these systems is that all of the commonly used alkanolamine solvents are subject to degradation processes, which can occur by three major routes<sup>109</sup>:

- Carbamate polymerisation
- Oxidative degradation
- Thermal degradation

In practical applications, the rate of carbamate polymerisation is insignificant at temperatures below 100°C, and thermal degradation only takes place at temperatures above 205°C. For the scrubbing of combustion flue gases at low temperatures, the amine degradation is largely due to the presence of significant oxygen concentrations in the flue gas. This is a significant problem with raw flue gases from coal fired systems.

The acid gases present in coal combustion flue gases, e.g. SO<sub>2</sub> and NO<sub>2</sub>, also react with MEA to form heat-stable salts, and this process reduces the CO<sub>2</sub> absorption capacity of the solvent<sup>110</sup>. These acid gas species have to be removed with reasonably high efficiency if amine scrubbing systems are to be used for CO<sub>2</sub> capture. In practical systems, the accumulation of these degradation products in the liquors circulating within the scrubbing and stripping units must be controlled.

There is also an issue associated with the relatively corrosive nature of the liquors circulating within the system, and there is significant development work associated with the control of the corrosion rates of the internal surfaces of the key plant items and with the selection of the appropriate materials of construction the reactors, pipework and other plant components.

Overall, therefore, it is clear that post-combustion capture technologies are end-of pipe solutions that can be retrofitted to an existing power plant or applied to new build plants.

The major disadvantage is that these technologies are relatively energy intensive and require a significant amount of steam for the regeneration of the solvent. Since this steam could be used to generate electrical power, the addition of capture will inevitably reduce the electrical output of the power plant facility and decrease its overall efficiency. Because the CO<sub>2</sub> concentration in the flue gas is relatively low (typically less than 20%) and the CO<sub>2</sub> loading of the solvents is modest, the capture systems also tend to be large, and have high capital cost<sup>111</sup>.

Much of the current developments are aimed therefore at finding improvements in the following subject areas:

- Optimisation of the amine formulations and the scrubbing/stripping cycle,
- Reduction of the energy requirement for the stripping of the loaded solvent,
- Minimisation of the costs associated with amine degradation, and
- Control of the corrosion of the internal surfaces of the scrubbing and stripping and associated equipment

### ***Main players internationally***

The major commercial companies involved in the development and demonstration of solvent scrubbing systems for power plant applications include MHI, HTC, Kerr McGee, Aker, Fluor, Alstom, Doosan Babcock, and Cansolv.

### ***Research activities, pilot and demonstration plants***

Because of these technical challenges, significant development of the amine scrubbing technology is required for its successful application to coal-fired plants. A number of demonstration and pilot plants have been built to study amine-based and other solvents for the capture of CO<sub>2</sub> from coal and natural gas flue gases<sup>109</sup>, including:

- On the pilot plant at the University of Texas in Austin, USA, an MEA campaign was conducted as a baseline to compare CO<sub>2</sub> absorption and stripping performance using an experimental potassium carbonate/piperazine solvent
- At Seoul thermal power plant, in Korea, a pilot plant treating 2 tonnes per day of CO<sub>2</sub> has been operated using MEA as the absorbent in a real flue gas side stream from Boiler Unit 5, a natural gas-fired boiler
- The CASTOR pilot plant, at Esbjerg power station in Denmark is a 1 tonne per hour unit using 30% aqueous MEA solution. The plant was operated at 93% CO<sub>2</sub> removal efficiency, producing approximately 850 kg/hour of CO<sub>2</sub>
- The ENEL slipstream pilot plant at Brindisi Sud power station, at 2.25 tonne CO<sub>2</sub> per hour, which will use 20 wt% MEA solution, is currently being built
- The Australian Low Emissions Technology Demonstration Fund (LETDF), is currently building two post-combustion capture projects. One is a natural gas combined cycle plant powered by coal bed methane, the other is a 25 tonnes per day capture plant on International Power's 1600 MW Hazelwood brown coal PCC plant in Victoria's Latrobe Valley
- At the CO<sub>2</sub> extraction plant at the Boundary Dam lignite fired power plant in Southern Saskatchewan, Canada, the pilot plant was used to evaluate the performance and reliability of proprietary CO<sub>2</sub> solvent extraction technologies, and to obtain engineering data that can be used for the design of commercial scale CO<sub>2</sub> absorption units

### ***The Fluor Econamine FG PLUS<sup>SM</sup> technology***

It is claimed that the degradation rate of the amine can be reduced by the addition of a proprietary inhibitor in a special Econamine FG<sup>SM</sup> solvent formulation<sup>112</sup>. This inhibitor also helps to protect the internal surfaces of the scrubbing and stripping equipment against corrosion, permitting the utilisation of lower cost materials of construction.

The flowsheet for the Fluor Econamine FG<sup>SM</sup> CO<sub>2</sub> scrubbing system is fairly conventional, and is very similar to that presented above. There are a number of plants worldwide that are now using the Econamine FG<sup>SM</sup> technology.

Fluor has developed a further improved process called Econamine FG Plus<sup>SM</sup> which is now being offered commercially. The predominant amine in the solvent still remains MEA, but the new formulation has increased reaction rates and higher capacity for CO<sub>2</sub>. Another feature of Econamine FG

Plus<sup>SM</sup> is a modified split flow configuration which utilises two parallel regeneration schemes, i.e. flash regeneration and steam stripping. The new configuration uses less steam than the standard Econamine FG<sup>SM</sup> arrangement, and has absorber inter-cooling to reduce the temperature in the middle of the absorber packed beds.

As with all the amine solvent systems, the Econamine FG Plus<sup>SM</sup> sorbent is affected by the formation of heat stable salts in the solution due to the presence of SO<sub>x</sub> and NO<sub>x</sub>, and by the presence of gas-borne particulates. Suitable flue gas treatment is therefore needed upstream of the Econamine FG Plus<sup>SM</sup> absorber.

#### *Kansai Mitsubishi Carbon Dioxide Recovery Process*

Mitsubishi Heavy Industries (MHI) offer a proprietary post-combustion flue gas CO<sub>2</sub> recovery system called Kansai Mitsubishi-Carbon Dioxide Recovery (KM-CDR) which has been developed from the generic amine gas treatment processes<sup>113</sup>. The system is based on a proprietary solvent KS-1<sup>TM</sup>, which has low corrosiveness and does not require a specific corrosion inhibitor. The KS-1<sup>TM</sup> system also offers superior CO<sub>2</sub> absorption and regeneration, lower solvent degradation rates, a lower solvent circulation rate and, with other patented equipment, has less solvent loss when compared to other amine based systems.

MHI has constructed four commercial CO<sub>2</sub> capture plants for recovering CO<sub>2</sub> from the combustion of natural gas and oil, and another four plants are currently in the pipeline. To develop the system for coal fired gas streams, a 10 t CO<sub>2</sub>/day demonstration facility was built in Matsushima, southern Japan. It is proposed that flue gas containing 14 vol% CO<sub>2</sub> will be taken at a rate of 1750 Nm<sup>3</sup>/hr in a slip stream from a coal fired boiler at Matsushima power plant.

#### *HTC Pureenergy CO<sub>2</sub> Capture Technology*

HTC in Regina, Canada has developed a CO<sub>2</sub> capture technology based on a relatively conventional scrubber unit, with the use of HTC Designer Solvents, which incorporate proprietary capacity enhancers, reaction rate promoters, solvent stabilisers and corrosion inhibitors, that can be tailored to specific applications.

#### *The Chilled Ammonia process for CO<sub>2</sub> capture*

Alstom has developed, and tested at laboratory scale, a process that uses chilled ammonia to capture CO<sub>2</sub> from combustion flue gases<sup>114</sup>. There are three separate process blocks:

- The first step involves the cooling of the flue gas, by direct injection of refrigerated water. As the gas is cooled, much of the water condenses, carrying some of the residual contaminants. The cooled flue gas leaves the cooling unit at 2°C and with less than 1% moisture
- The second process step is CO<sub>2</sub> absorption, using an aqueous slurry containing a mixture of ammonium carbonate (AC) and ammonium bicarbonate (ABC). Any residual ammonia is captured by a cold-water wash and returned to the absorber
- The third step takes the CO<sub>2</sub>-rich ABC slurry and pumps it to the high pressure (1,200 to 1,500 psi) regenerator unit, through a heat exchanger, which increases the temperature to around 80°C. The CO<sub>2</sub> released from the slurry at the elevated temperature in the regenerator is washed and sent for further processing. The lean AC is returned to the absorber tower, via the heat exchanger

The only by-product of the entire process is a small amount of water; which can either be treated for disposal by the waste water system, or is recycled and reused.

Alstom, together with the Electric Power Research Institute (EPRI) and We Energies, has launched a pilot project to demonstrate CO<sub>2</sub> capture from coal-fired power plants using the chilled ammonia process. It is proposed that the pilot plant, rated at the equivalent of 1.7 MW, will capture CO<sub>2</sub> from a flue gas side stream at Pleasant Prairie Power Plant, a 1,224 MW coal-fired generating station.

Alstom and Statoil are also planning to test chilled ammonia technology for CO<sub>2</sub> capture from flue gases from natural gas combined cycle power plants. A 40 MW facility will be built at the Mongstad refinery in Norway for testing and product validation. It will be designed to capture at least 80,000 tons per year of CO<sub>2</sub> from flue gases from the cracker unit at the refinery or from a new combined heat and power plant being built by Statoil and which is scheduled to be in operation by 2010. The test and product validation facility is expected to enter operation by 2009-2010 with the first operation and testing phase to last 12-18 months.

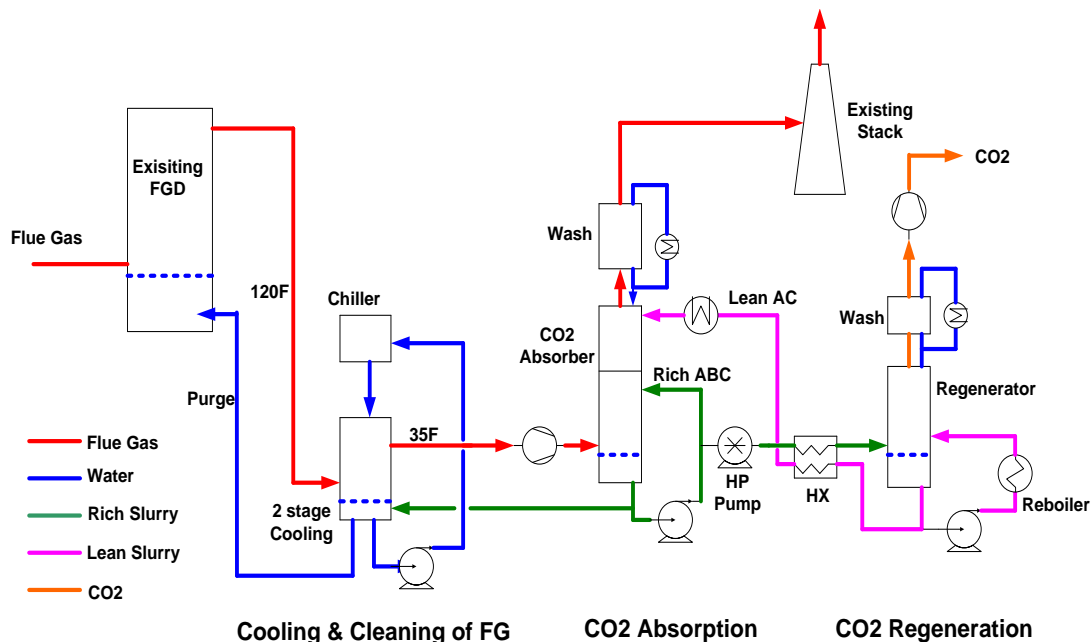

Figure 2.13: Schematic of the Alstom chilled ammonia process<sup>115</sup>

### Implications of retrofitting to an existing plant

The solvent scrubbing plants can be retrofitted to existing power plants, however they are relatively large plant with a significant footprint, and the retrofit will inevitably involve major extension of the existing flue gas ductwork, in areas which are normally relatively restricted for space. This will be highly site specific and will have a significant impact on the capital costs associated with retrofit projects.

### Technology Readiness Level

Post combustion CO<sub>2</sub> capture using solvent scrubbing is at small-scale demonstration scale (TRL 6) moving to larger scale demonstration, for coal firing, but has not as yet been applied commercially to biomass co-firing or 100% biomass firing in converted pulverised coal boilers. A number of the proposed demonstration scale projects at coal plants indicate that they may include biomass co-firing.

Given the very high levels of industrial activity and investment in the area, solvent scrubbing technologies for post-combustion CO<sub>2</sub> capture could reach TRL 8 to 9 by 2020.

### ***UK activities and capabilities***

There are pilot scale, flue gas side stream, solvent scrubbing systems installed or currently being built at Longannet power station in Scotland and at Ferrybridge power station.

Doosan Babcock are actively involved in the development and marketing of amine scrubbing systems. A number of projects have proceeded to FEED study stage.

Three of the UK's recent seven CCS applications to the EU's NER300 competition are planning to involve post-combustion amine scrubbing<sup>116</sup>:

- Scottish Power Generation Limited: capture retrofitted to an existing subcritical coal-fired power station at Longannet, Scotland
- Peel Energy CCS Ltd: a new supercritical coal-fired power station in Ayrshire, Scotland
- SSE Generation Limited: capture retrofitted to an existing CCGT power station at Peterhead, Scotland

The UK's Demonstration Programme has confirmed £1bn in capital expenditure for its first demonstration project – likely to be at Longannet, Scotland. This remains the largest confirmed commitment to a single commercial-scale CCS project in the world. DECC are currently finalising the design of the selection process, and deciding on funding avenues, for another three UK demonstration projects<sup>117</sup>.

### ***Environmental factors***

The chilled ammonia and organic amines used as CO<sub>2</sub> solvents have specific delivery and on-site handling requirements to minimise spillage and leakage of the reagents, and to control the impact when spillages do occur.

There may be specific issues associated with the levels of amine slip into the cleaned flue gas and the CO<sub>2</sub> streams, and the efficiency requirements for the demisting systems. There may also be specific issues associated with the potential for leakage of amines into the cooling water and waste water systems on the power plant, and a requirement to monitor and control these risks.

These potential issues have been recently brought into the fore-front of public attention, with Statoil being blamed for exaggerating the health risks posed by amines when they decided to further delay their Mongstad gas-fired CCS demonstration project in Norway<sup>118</sup>.

### ***Technical and economic characteristics***

#### ***Equipment scales***

Solvent scrubbing systems are applicable to all scales of operation relevant to coal-fired and biomass energy conversion systems, i.e. 10 to 1,000 MW<sub>e</sub>. Currently, solvent scrubbing systems are being designed for the largest coal-fired power plant boilers. However, there remain a few doubts about the ability to scale up the amine scrubbing towers to the sizes required for large-scale power applications, since towers 20 metres in diameter have not yet been built or operated.



**CO<sub>2</sub> capture rate, efficiency and economics**

A very valuable review of the techno-economic data published between 2006 and 2010 on CO<sub>2</sub> capture from power generation was recently carried out by Finkenrath, for the IEA<sup>119</sup>. The study focuses on CO<sub>2</sub> capture from new-build coal-fired and natural gas-fired power generation plants above 300 MW<sub>e</sub> power output. Dedicated biomass-fired plants were not evaluated in this review, but there was one case study with biomass co-firing.

The evaluation of coal-fired power generation with post-combustion CO<sub>2</sub> capture analysed 14 different cases, including sub-critical (sub-PC), supercritical (SCPC) and ultra-supercritical (USCPC) pulverized coal boilers. The data table, including the biomass co-firing case, has been reproduced in Table 2.7.

**Table 2.7: Post-combustion capture from coal power plants using amines (only 1 case co-firing 10% biomass)<sup>119</sup>**

Regional focus	OECD														China	Average (OECD)	
Year of cost data	2005	2005	2005	2005	2007	2007	2007	2007	2007	2007	2007	2009	2009	2009	2009		
Year of publication	2007	2007	2007	2007	2009	2009	2009	2009	2010	2010	2009	2009	2009	2009			
Organisation	CMU	MIT	GHG IA	GHG IA	EPRI	EPRI	EPRI	MIT	NETL	NETL	GCCSI	GCCSI	GHG IA	NZEC			
<b>ORIGINAL DATA AS PUBLISHED (converted to USD)</b>																	
Region	US	US	EU	EU	US	US	US	US	US	US	US	US	EU	CHN			
Specific fuel type	Bit coal	Lignite	Bit coal	Bit coal	Sub-bit coal	Sub-bit coal	Bit coal	Bit coal	Bit coal	Bit coal	Bit coal	Bit coal	Bit+10% Biomass	Bit coal			
Power plant type	SCPC	CFB	USCPC	USCPC	SCPC	USCPC	SCPC	SCPC	SCPC	Sub-PC	SCPC	USCPC	SCPC	USCPC			
Net power output w/o capture (MW)	528	500	758	758	600	600	600	500	550	550	550	550	519	824	582		
Net power output w/ capture (MW)	493	500	666	676	550	550	550	500	550	550	550	550	399	622	545		
Net efficiency w/o capture, LHV (%)	41.3	36.5	44.0	44.0	39.2	39.8	40.0	40.4	41.2	38.6	41.4	46.8	44.8	43.9	41.4		
Net efficiency w/ capture, LHV (%)	31.4	26.7	34.8	35.3	28.2	28.8	29.1	30.7	29.9	27.5	29.7	34.9	34.5	33.1	30.9		
CO <sub>2</sub> emissions w/o capture (kg/MWh)	811	1030	743	743	879	865	836	830	802	856	804	707	754	797	820		
CO <sub>2</sub> emissions w/ capture (kg/MWh)	107	141	117	92	124	121	126	109	111	121	112	95	73	106	111		
Capital cost w/o capture (USD/kW)	1 442	1 330	1 408	1 408	2 061	2 089	2 007	1 910	2 024	1 996	2 587	2 716	1 710	856	1 899		
Capital cost w/ capture (USD/kW)	2 345	2 270	1 979	2 043	3 439	3 485	3 354	3 080	3 570	3 610	4 511	4 279	2 790	1 572	3 135		
Relative decrease in net efficiency	24%	27%	21%	20%	28%	28%	27%	24%	28%	29%	28%	26%	23%	25%	25%		
<b>RE-EVALUATED DATA (2010 USD)</b>																	
Overnight cost w/o capture (USD/kW)	1 508	1 868	1 720	1 720	2 580	2 615	2 512	2 391	2 203	2 172	2 409	2 529	1 873	938	2 162		
Overnight cost w/ capture (USD/kW)	2 664	3 404	2 581	2 664	4 596	4 657	4 482	4 116	4 148	4 195	4 485	4 255	3 263	1 838	3 808		
LCOE w/o capture (USD/MWh)	50	49	69	69	62	63	73	70	65	66	70	70	78	51	66		
LCOE w/ capture (USD/MWh)	80	84	95	97	107	109	121	112	113	117	121	112	118	80	107		
Cost of CO <sub>2</sub> avoided (USD/tCO <sub>2</sub> )	43	40	42	42	60	61	68	58	69	69	74	68	59	42	58		
Relative increase in overnight cost	77%	82%	50%	55%	78%	78%	78%	72%	88%	93%	86%	68%	74%	96%	75%		
Relative increase in LCOE	59%	73%	38%	40%	72%	72%	67%	60%	73%	77%	73%	59%	52%	57%	63%		

Notes: Data cover only CO<sub>2</sub> capture and compression but not transportation and storage. Overnight costs include owner's, EPC and contingency costs, but not IDC. A 15% contingency based on EPC cost is added for unforeseen technical or regulatory difficulties for CCS cases, compared to a 5% contingency applied for non-CCS cases. IDC is included in LCOE calculations. Fuel price assumptions differ between regions.

This data indicates that the installation of post-combustion CO<sub>2</sub> capture to a new build coal-fired power plant of capacity around 500-600 MW<sub>e</sub> would:

- Capture on average 87% of the emitted CO<sub>2</sub> (with a range of capture rates from 84% to 90%)
- Decrease the plant efficiency by 25% on average, i.e. between 8.7 and 12.0 %-points (LHV)

- Increase the overnight specific capital costs by 75% on average (with a range from 60% to 90%). This is from an average of 2,162 \$/kW<sub>e</sub> increasing to 3,808 \$/kW<sub>e</sub> (i.e. 1,372 £<sub>2011</sub>/kW<sub>e</sub> increasing to 2,417 £<sub>2011</sub>/kW<sub>e</sub>)
- Increase the LCOE by 63% on average (with a range from 50% to 75%). This is from an average of 66 \$/MWh increasing to 107 \$/MWh (i.e. 42 £<sub>2011</sub>/MWh increasing to 68 £<sub>2011</sub>/MWh)

Now, looking more specifically at biomass CCS (instead of just coal CCS), IEAGHG published an important study of the performance and costs of adding CO<sub>2</sub> capture based on standard MEA post combustion capture technologies – for “standalone” biomass fired power plants and for biomass co-fired with coal power plants<sup>120</sup>. The study evaluated the techno-economic performance of incorporating CO<sub>2</sub> capture for the following four cases, with further plant configuration details given in Table 2.8:

- Case 1: 500 MW<sub>e</sub> (net) co-firing of biomass and coal in PCC power plant
- Case 2: 500 MW<sub>e</sub> (net) co-firing of biomass and coal in CFB power plant
- Case 3: 250 MW<sub>e</sub> (net) CFB standalone biomass power plant
- Case 4: 75 MW<sub>e</sub> (net) BFB standalone biomass power plant

**Table 2.8: Summary and key features of the power plants evaluated in the IEAGHG Biomass CCS study<sup>120</sup>**

Case	Boiler Technology	Steam Parameter	Fuel	Key Technology Features	CO <sub>2</sub> Capture	DeSOx	DeNOx
1A	PC	supercritical	90% Coal / 10% Biomass	None	No	FGD	SCR
1B	PC	supercritical	90% Coal / 10% Biomass	None	Yes	FGD	SCR
2A	CFB	supercritical	90% Coal / 10% Biomass	Inclusion of special plastic HEX for flue gas heat recovery	No	Limestone Injection in Furnace	None
2B	CFB	supercritical	90% Coal / 10% Biomass	None	Yes	Limestone Injection in Furnace & FGD	None
3A	CFB	subcritical	100% Biomass	Inclusion of special plastic HEX for flue gas heat recovery	No	None	None
3B	CFB	subcritical	100% Biomass	None	Yes	Limestone Injection in Furnace	None
4A	BFB	subcritical	100% Biomass	None	No	None	None
4B	BFB	subcritical	100% Biomass	None	Yes	Limestone Injection in Furnace	None

A summary of the IEAGHG results are presented in Table 2.9. For the “B” cases with capture, the thermal LHV efficiencies range from as low as 23% for the small BFB, up to 34.5% for a co-firing supercritical PCC. This reflects the significant penalty incurred by the subcritical units (12 to 16 %-points), compared to the supercritical units (10 to 12 %-points). This is due to:

- Installation of additional flue gas clean equipment (i.e. addition of an external FGD for Case 2B, introduction of limestone injection into the furnace for Cases 3B and 4B) to achieve the required quality of the flue gas before introduction to the CO<sub>2</sub> capture units increases the loss of net efficiency of the power plant

- The installation of a Direct Contact Cooler, which is necessary to reduce the particulate matter introduced into the CO<sub>2</sub> capture plant, does not allow the recovery of low grade heat that could be used by the power plant. In Cases 2A and 3A, plant efficiencies have been increased by several %-points above today's best-in-class by the introduction of a novel plastic heat exchanger to maximise flue gas heat recovery – but this type of heat exchanger cannot be applied if an external FGD or CO<sub>2</sub> capture units are installed
- The lower LHV of biomass fuel compared to coal – hence more heat is produced at low temperature, but which cannot be captured
- Furthermore, the volume of flue gas from a standalone biomass fired power plant to be handled by the CO<sub>2</sub> capture unit is proportionally larger than a similar sized coal fired boiler, thereby requiring larger process equipment and increased auxiliary power requirements. Additionally, the CO<sub>2</sub> in the flue gas from a dedicated biomass combustion plant is more dilute than that from a coal fired boiler

The cost estimates for the CO<sub>2</sub> capture equipment and the CO<sub>2</sub> drying and compression plant are included for each of these cases. The data indicate that the additional capital costs of the on-site carbon dioxide capture and compression equipment add around 25-40% to the total capital costs of the power plant, depending on the scale of operation. However, with the drop in efficiencies, this equates to an increase in overnight specific capital costs of 65-75% for the co-firing plants (in line with the IEA review above), and 115-130% for the dedicated biomass plants.

**Table 2.9: Summary of performance and cost of the biomass fired or co-fired power plants<sup>120</sup>**

	Biomass Thermal Input	Net Power Output	Net Efficiency (LHV)	Total Investment Cost	Capital Cost
	%	MW	%	MM €	€/kWe net
<b>SC PC boiler co-fired with biomass</b>					
Case 1A (without CO <sub>2</sub> capture)	10	518.9	44.8	657.2	1266.5
Case 1B (with CO <sub>2</sub> capture)	10	398.9	34.5	824.3	2066.5
<b>SC CFB boiler co-fired with biomass</b>					
Case 2A (without CO <sub>2</sub> capture)	10	521.4	45.1	707.3	1356.5
Case 2B (with CO <sub>2</sub> capture)	10	390.5	33.8	918.4	2351.8
<b>Sub CFB boiler fired with biomass</b>					
Case 3A (without CO <sub>2</sub> capture)	100	273.0	41.7	370.3	1356.4
Case 3B (with CO <sub>2</sub> capture)	100	168.9	25.8	519.7	3077.2
<b>Sub BFB boiler fired with biomass</b>					
Case 4A (without CO <sub>2</sub> capture)	100	75.8	36.0	185.4	2446.1
Case 4B (with CO <sub>2</sub> capture)	100	48.9	23.2	256.2	5240.1

The CO<sub>2</sub> emission levels with and without carbon capture are summarised in Table 2.10 below. In each case, a commercial CO<sub>2</sub> capture rate of 90% has been assumed, and this is not unreasonable for processes of this type. Higher CO<sub>2</sub> capture rates and CO<sub>2</sub> purity levels can be achieved with solvent scrubbing systems; however these will incur significantly higher capital and operating costs.

**Table 2.10: Summary of CO<sub>2</sub> emissions of the biomass fired or co-fired power plants<sup>120</sup>**

	Actual CO <sub>2</sub> Emissions	CO <sub>2</sub> from Coal	CO <sub>2</sub> from Biomass	Total CO <sub>2</sub> Captured	Equivalent CO <sub>2</sub> Emissions	CO <sub>2</sub> avoided wrt conventional coal	CO <sub>2</sub> avoided wrt NGCC
	g/kWh	g/kWh	g/kWh	g/kWh	g/kWh	g/kWh	g/kWh
SC PC Coal fired boiler (w/o CO <sub>2</sub> capture)	722.8	722.8	-	-	722.8	-	-
NGCC (without CO <sub>2</sub> capture)	359.0	359.0	-	-	359.0	-	-
<b>SC PC boiler co-fired with biomass</b>							
Case 1A (without CO <sub>2</sub> capture)	748.5	649.7	98.8	0.0	649.7	73.1	-290.7
Case 1B (with CO <sub>2</sub> capture)	973.7	845.2	128.5	876.4	-31.3	754.1	390.3
<b>SC CFB boiler co-fired with biomass</b>							
Case 2A (without CO <sub>2</sub> capture)	748.2	649.4	98.8	0.0	649.4	73.4	-290.4
Case 2B (with CO <sub>2</sub> capture)	999.0	867.1	131.9	899.1	-32.0	754.8	391.0
<b>Sub CFB boiler fired with biomass</b>							
Case 3A (without CO <sub>2</sub> capture)	1081.3	0.0	1081.3	0.0	0.0	722.8	359.0
Case 3B (with CO <sub>2</sub> capture)	1747.8	0.0	1747.8	1573.1	-1573.1	2295.9	1932.2
<b>Sub BFB boiler fired with biomass</b>							
Case 4A (without CO <sub>2</sub> capture)	1257.3	0.0	1257.3	0.0	0.0	722.8	359.0
Case 4B (with CO <sub>2</sub> capture)	1948.9	0.0	1948.9	1754.6	-1754.6	2477.4	2113.7

Laczay<sup>121</sup> carried also out a study where comparable case models were developed to describe dedicated biomass, biomass co-firing with coal and conventional fossil fuel combustions power plants, all with and without CCS technology. The models used data from existing power plant facilities and from previous studies to estimate GHG emissions and costs for each case. Without CCS, the results showed that the total GHG emissions for coal were highest, and natural gas combined cycle had the second highest emissions. Both of the dedicated biomass systems had very low CO<sub>2</sub> emissions compared to the fossil fuel cases. The co-fired cases ranged according to the co-firing rates. With the use of CCS, as expected, the CO<sub>2</sub> emissions were significantly decreased in all cases.

- 
- <sup>105</sup> IPCC, Special Report on Carbon Dioxide Capture and Storage, Prepared by Working Group III of the Intergovernmental Panel on Climate Change [Metz, B., O. Davidson, H.C. de Coninck, M. Loos, and L.A. Meyer (eds.)]. Cambridge University Press, Cambridge, United Kingdom and New York, NY, USA, 442 pp., 2005.
- <sup>106</sup> Elwell, L. C., Grant, W. S., Technical Overview of Carbon Dioxide Capture Technologies for Coal-Fired Power Plants, 2005.
- <sup>107</sup> Panesar, R., Lord, M., Simpson, S., White, V., Gibbins, J., Reddy, S., Coal-Fired Advanced Supercritical Boiler/Turbine Retrofit with CO<sub>2</sub> Capture, 8<sup>th</sup> International Conference on Greenhouse Gas Control Technologies, Trondheim, Norway, June, 2006.
- <sup>108</sup> IEA Greenhouse Gas R&D Programme, CO<sub>2</sub> Capture Ready Plants, Technical Study, Report Number 2007/4, May 2007.
- <sup>109</sup> Davidson, R.M., Post-Combustion Carbon Capture from Coal Fired Plants – Solvent Scrubbing, CCC/125, IEA Clean Coal Centre, 2007.
- <sup>110</sup> Rubin, E. S., Rao, A. B., A technical, economic and environmental assessment of amine-based CO<sub>2</sub> capture technology for power plant greenhouse gas control, Report no. DOE/DE-FC26-00NT40935, Carnegie Mellon University, Center for Energy and Environmental Studies, Pittsburgh, PA, 2002.
- <sup>111</sup> Oxy-Coal Technology for Carbon Dioxide Capture: Worldwide Development Activity Update, EPRI, Palo Alto, CA 2010. 1019673, December 2010.
- <sup>112</sup> Reddy, S., Scherffius, J., Freguia, S., Roberts, C., Fluor’s Econamine FG PlusSM technology – An enhanced amine-based CO<sub>2</sub> capture process, 2<sup>nd</sup> National Conference on Carbon Sequestration, Alexandria, VA, May, 2003.
- <sup>113</sup> Mitchell, R. (2008) “Mitsubishi Heavy Industries’ carbon capture technology”, Carbon Capture Journal, February 2008
- <sup>114</sup> Carbon capture: Inside Alstom’s chilled ammonia CO<sub>2</sub> capture system, Power, Feb 2008.
- <sup>115</sup> Black, S., Bade, O., Padban, N., Gal, E., Morris, E., Rhudy, D., Chilled ammonia process for CO<sub>2</sub> capture, Power-Gen Europe, Madrid, Spain, 26 – 28 June 2007
- <sup>116</sup> DECC (10 May 2011) “Cutting-edge UK energy projects in running for EU funding”, available at: [http://www.decc.gov.uk/en/content/cms/news/pn11\\_39/pn11\\_39.aspx](http://www.decc.gov.uk/en/content/cms/news/pn11_39/pn11_39.aspx)
- <sup>117</sup> DECC (2011) “UK Carbon Capture and Storage (CCS) Commercial Scale Demonstration Programme: Delivering Projects 2-4”, available at: <http://www.decc.gov.uk/assets/decc/What%20we%20do/UK%20energy%20supply/Energy%20mix/Carbon%20capture%20and%20storage/1075-uk-ccs-commercial-scale-demonstration-programme-fu.pdf>
- <sup>118</sup> Bellona (2011) “Mongstad CCS project delayed – again”, available at: [http://www.bellona.org/articles/articles\\_2011/postponed\\_mongstad](http://www.bellona.org/articles/articles_2011/postponed_mongstad)
- <sup>119</sup> Finkenrath, M., Cost and Performance of Carbon Dioxide Capture from Power Generation Working Paper, International Energy Agency, 2011.
- <sup>120</sup> IEA Greenhouse Gas R&D Programme, “Biomass CCS Study”, Report Number:2009/9, November 2009.
- <sup>121</sup> Laczay, S., A Comparative Analysis of the Economics and GHG Emissions of Fossil Fuel, Co-Fired and Dedicated Biomass Electricity Generation Systems with Carbon Capture and Storage in the UK, MSc Thesis, Executive Summary, Centre for Environmental Policy, Imperial College, London, Academic Year 2008-2009. <http://workspace.imperial.ac.uk/environmentalpolicy/public/Laczay%2009%20Executive%20Summary.pdf>

### 2.3.2 Post-combustion capture: Low temperature solid sorbents

Low temperature solid sorbents capture CO<sub>2</sub> by absorption from flue gas on to a generally high surface area, porous, solid. Such a reaction could take place within a fixed or fluidised reactor (either a circulating or a bubbling bed). The CO<sub>2</sub> is then desorbed, either by transport to a different reactor or within the same reactor (with the flue gas being switched between two or more reactors to allow continuous treatment of flue gas). The heat to effect the desorption of the CO<sub>2</sub> comes from steam diverted from the low pressure turbine of the power station, in a similar manner to standard amine-based post combustion capture. There are a number of different types of porous solid which have been proposed for this technology. Five of the major types, as classified by Drage<sup>122</sup> are detailed below:

- 1) Supported amines. Amines are physically attached to the surface of a porous material such as a polymer or an inorganic support<sup>123,124</sup>
- 2) Immobilized amines. Similar to 1), but with the amine functional group chemically bound to the surface of the porous material, for example silica or carbon<sup>125,126</sup>
- 3) Activated carbons. These are extremely high surface area compounds generated from carbonaceous materials, including chars<sup>127,128,129,130,131</sup>
- 4) Hydrotalcites<sup>132</sup>, the surfaces of which can be modified to enhance their CO<sub>2</sub> uptakes; zeolites<sup>133</sup>
- 5) Metal Organic Frameworks (MOFs)<sup>134</sup>

There have been numerous reviews of the use of solid sorbents for CO<sub>2</sub> uptake, a recent one by the IEA<sup>135</sup> is possibly the most comprehensive. The work of Gray et al<sup>136</sup> suggests that for low temperature CO<sub>2</sub> sorbents to be competitive (this is defined as “reducing the regeneration energy by 30 – 50 %) it is necessary for the loading of CO<sub>2</sub> on them to exceed 3 mmol/g. However, it is important to note that this figure is based on an unpublished NETL report and must be verified prior to acceptance.

#### ***Key drivers for development***

One advantage of supported amines (options 1 and 2) is that by separating the amine physically from the scrubbing tower, there is less corrosion of the scrubbing tower by the amine solution (the reason that MEA concentration is limited in a standard amine scrubbing system is that oxidative degradation of the amines leads to highly corrosive products<sup>137</sup>). Indeed, the oxidative degradation of MEA is enhanced by catalysis from iron products dissolving into the solvent, exacerbating the degradation<sup>138,139,140</sup>. By physically separating the scrubbing tower from the amine, the degradation cycle is broken. This work will focus on supported amine sorbents, as the closest to commercial application.

#### ***Development aspects and prospects***

#### ***Key development issues***

There is a great deal of research ongoing into low temperature sorbents. Each sorbent must satisfy a number of essential criteria, but getting sorbents with the right combination of high uptake, selectivity towards CO<sub>2</sub>, low heat of adsorption in the correct temperature range, resistance to water (this can be a significant hurdle), sulphur, oxygen and all of the other components of flue gas is not a

simple task. Furthermore, there are significant barriers to overcome associated with both reaction engineering and systems integration. However, these sorbents are a significant improvement on the current state of the art, should these difficulties be overcome.

Metal organic frameworks MOFs<sup>141, 142</sup>, covalent organic framework (COFs)<sup>143</sup> and zeolitic imidazolate frameworks (ZIFs)<sup>144</sup> are microporous crystalline materials. These can exhibit very high surface areas, owing to their highly structured porous internal lattice. However, some are highly unstable in the presence of moisture – and can degrade even at room temperature<sup>145</sup>. Water can also act as a competitor to CO<sub>2</sub> for adsorption sites.

In summary, further sorbent development is required, to ensure that sorbents are available that have both CO<sub>2</sub> uptake capacity > 3 mmol/g but also resistance to water, SO<sub>2</sub>, etc. However, it is likely that these will be developed. Aside from this, process integration and large scale testing are required, including assessment of thermal cycling of materials over long numbers of cycles. Some testing already involves the presence of water<sup>146</sup> and some sorbents are not affected to a significant degree.

Each sorbent will have different gas specifications, though with appropriate SO<sub>2</sub> scrubbing it is unlikely that any sorbents which are currently being developed for commercial use will impose significant specifications on the gas composition.

### ***Environmental factors***

Disposal issues are reduced for supported amines as opposed to standard MEA based scrubbing. It is also likely that there will be lower fugitive losses of amines from these systems, owing to the immobilisation of the amine. However, it is possible that there will be losses of particles owing to fragmentation of the particles, owing to both thermal cycling and attrition. Careful design of cyclones would be required in order to remove such particles and to prevent their emissions.

### ***Implications of retrofitting to an existing plant***

The retrofit implications for this technology are the same as those for MEA scrubbing – there should be few hurdles to integration with an existing plant. However, it is important to note that only systems which have been proven to have no issues with water vapour or low quantities of sulphur within them should be considered for post combustion retrofit. Furthermore, there are issues with activated carbons and zeolites (i.e. physical sorbents), which perform well at ambient temperatures but have a marked reduction in their ability to take up CO<sub>2</sub> at typical flue gas temperatures<sup>127,124,129</sup>. In order to overcome these issues, sorbents have been altered in order to enhance chemical adsorption as opposed to physical adsorption. Such modifications have resulted in the production of some of the more effective CO<sub>2</sub> sorbents<sup>123,147,148,136</sup>.

### ***Main players internationally***

The US DOE has also funded significant research in this area<sup>149</sup>. ADA Environmental solutions has a large research activity (\$15million contract recently signed with DOE, including \$3.75million from industry). CSIRO (Australia) have also conducted lab-scale testing with activated carbon.

### ***UK capabilities***

The UK has a number of significant research projects ongoing in this area. The EPSRC has funded two consortia which have significant research interests in this field. Firstly, the University of Edinburgh

leads a consortium<sup>150</sup> (£1.9 million) investigating these technologies, amongst others. Secondly, the University of Nottingham leads another consortium (£1.6 million) investing similar processes<sup>151</sup>. Both consortia are progressing well, with high throughput screening of sorbents ongoing.

However, in the UK, there is no industrial experience with low-temperature solid sorbents. There is also little operational experience with fluidised beds. However, fluid catalytic crackers are used at a large scale in the UK.

### ***Technology Readiness Level, pilot and demonstration plants***

The current TRL of low-temperature solid sorbents is TRL 4, i.e. “Component and/or partial system validation in a laboratory environment”

In terms of a likely TRL in 2020, although there is a great deal of research ongoing in this area, we are aware of no demonstrations of the order of  $\geq 1$  MW<sub>e</sub> currently in the process of being constructed. Current pilot work appears to be in the 1 kW scale<sup>149</sup>. However, in 2010, ADA Environmental Solutions were awarded a \$15 million second-stage contract to move demonstration to the 1MW scale, with \$3.5 million of industrial support<sup>152</sup>.

The US DOE has highly ambitious plans to move the TRL to full commercialisation by 2020. Its intermediate year targets are also highly ambitious, with validation at 1-5 MW by 2012, 30 MW by 2016 and commercial deployment by 2020<sup>149</sup>. However, experience with the commercialisation of chilled ammonia scrubbing indicates that there may be significant hurdles along the way.

With a more realistic mindset, it is reasonable to suggest that this technology would actually be ready for large scale deployment in 2030. Demonstration of the technology could be done in the UK between 2020 and 2025, which is likely to be slightly slower than the planned demonstration targets in the USA.

### ***Technical and economic characteristics***

#### ***Equipment scales***

Carbonate looping is based on fluidised bed technology, which is very suited to both small and large scale operation (between 10 – 1000 MW<sub>e</sub>).

#### ***Flexibility***

It is expected that there will be no major issues with flexibility – it is likely that these systems will be at least as rapid to start up as amine scrubbing systems. Load following should not be an issue.

#### ***Economics***

There is little available literature where careful costings have been done. However, it is possible to estimate the costs for the most likely system, a circulating fluidised bed, by analogy with the costs for power generation. In essence, the scrubbing system operates a little like a power plant in reverse – in a standard power plant, combustion of fuel is used to heat a steam coil within the CFB, whereas in post combustion capture in a CFB a steam coil is used to transfer heat to the regeneration bed. A very approximate estimate could therefore be made that it is likely that the costs of either system will be comparable. The CFB will be less expensive than a CFB combustor because there will be no requirement for turbines, but on the other hand the supported amine sorbents will be substantially



more expensive than standard MEA. Romeo et al<sup>25</sup> suggest that a cost of €1100 / kW is appropriate for a CFB system, though the costs here will be lower because turbines will not be necessary. A very approximate cost is therefore suggested of €400 / kW<sub>th</sub>, based on regeneration *heat* demand, not overall plant electricity supplied.

Very little work has been done on cost of electricity with such a system added. The sorbent is expensive, but the capital costs for the treatment unit should be lower than those for an amine-based system, owing to the use of mature fluidised bed technology. As discussed in the section on Ca looping, circulating fluidised beds have already been built at the scale required for this application, reducing the technology risk inherent in scale-up. A very approximate cost of electricity is therefore suggested to be €50 / tonne of CO<sub>2</sub> avoided.

Similarly to other more novel post-combustion capture technologies, the future goal of the US DOE programme with ADA is to develop a capture system that results in an LCOE increase of less than 35% from the plant without capture<sup>149</sup>.

### **CO<sub>2</sub> capture rate**

ADA environmental solutions have demonstrated that such systems can capture up to 90 % of the CO<sub>2</sub> in the exhaust stream<sup>153</sup>, though over 10 cycles in a 1 kW pilot plant system the capture shown varied between 70 and 90 %. Proper design of equipment should ensure that high capture is possible.

### **Plant efficiency with / without capture**

The aim for these sorbents is to reduce the energy requirement for CO<sub>2</sub> capture by 30 – 50 % compared to MEA scrubbing capture systems<sup>154</sup>. This would lead to a total efficiency penalty of 6 – 8 points, as opposed to 9 – 12 points for MEA scrubbing. In a recent evaluation of 24 different sorbents by ADA Environmental Solutions, 11 were identified as theoretically having a lower regeneration energy than aqueous MEA, some as little as 37.5 % of the required energy of MEA<sup>155</sup>.

---

<sup>122</sup> Drage, T. C. (2011) Private Communication

<sup>123</sup> Xu, X. C., C. S. Song, et al. (2002). "Novel polyethylenimine-modified mesoporous molecular sieve of MCM-41 type as high-capacity adsorbent for CO<sub>2</sub> capture." *Energy & Fuels* **16**(6): 1463-1469

<sup>124</sup> Drage, T. C., A. Arenillas, et al. (2008). "Thermal stability of polyethylenimine based carbon dioxide adsorbents and its influence on selection of regeneration strategies." *Microporous and Mesoporous Materials* **116**(1-3): 504-512.

<sup>125</sup> Harlick, P. J. E. and A. Sayari (2007). "Applications of pore-expanded mesoporous silica. 5. Triamine grafted material with exceptional CO<sub>2</sub> dynamic and equilibrium adsorption performance." *Industrial & Engineering Chemistry Research* **46**(2): 446-458.

<sup>126</sup> Serna-Guerrero, R., E. Da'na, et al. (2008). "New Insights into the Interactions of CO<sub>2</sub> with Amine-Functionalized Silica." *Industrial & Engineering Chemistry Research* **47**(23): 9406-9412.

<sup>127</sup> Arenillas, A., T. C. Drage, et al. (2005). "CO<sub>2</sub> removal potential of carbons prepared by co-pyrolysis of sugar and nitrogen containing compounds." *Journal of Analytical and Applied Pyrolysis* **74**(1-2): 298-306.

<sup>128</sup> Maroto-Valer, M. M., Z. Tang, et al. (2005). "CO<sub>2</sub> capture by activated and impregnated anthracites." *Fuel Processing Technology* **86**(14-15): 1487-1502

<sup>129</sup> Pevida, C., T. C. Drage, et al. (2008). "Silica-templated melamine-formaldehyde resin derived adsorbents for CO<sub>2</sub> capture." *Carbon* **46**(11): 1464-1474.

<sup>130</sup> Olivares-Marín, M. and M. M. Maroto-Valer (2011). "Preparation of a highly microporous carbon from a carpet material and its application as CO<sub>2</sub> sorbent." *Fuel Processing Technology* **92**(3): 322-329.

<sup>131</sup> Drage, T. C., A. Arenillas, et al. (2007). "Preparation of carbon dioxide adsorbents from the chemical activation of urea-formaldehyde and melamine-formaldehyde resins." *Fuel* **86**(1-2): 22-31.

- <sup>132</sup> Walspurger, S., L. Boels, et al. (2008). "The Crucial Role of the K+-Aluminium Oxide Interaction in K+-Promoted Alumina- and Hydrotalcite-Based Materials for CO<sub>2</sub> Sorption at High Temperatures." *Chemosuschem* **1**(7): 643-650
- <sup>133</sup> Xiao, P., J. Zhang, et al. (2008). "Capture of CO<sub>2</sub> from flue gas streams with zeolite 13X by vacuum-pressure swing adsorption." *Adsorption-Journal of the International Adsorption Society* **14**(4-5): 575-582.
- <sup>134</sup> Torrisi, A., R. G. Bell, et al. (2010). "Functionalized MOFs for Enhanced CO<sub>2</sub> Capture." *Crystal Growth & Design* **10**(7): 2839-2841
- <sup>135</sup> Davidson, R. (2009). "Post-combustion carbon capture – solid sorbents and membranes."
- <sup>136</sup> Gray, M. L., K. J. Champagne, et al. (2008). "Performance of immobilized tertiary amine solid sorbents for the capture of carbon dioxide." *International Journal of Greenhouse Gas Control* **2**(1): 3-8
- <sup>137</sup> Soosaiprakasam, I. R. and A. Veawab (2008). "Corrosion and polarization behavior of carbon steel in MEA-based CO<sub>2</sub> capture process." *International Journal of Greenhouse Gas Control* **2**(4): 553-562.
- <sup>138</sup> Chi, S. and G. Rochelle (2001). Oxidative Degradation of Monoethanolamine. *First International Conference on CO<sub>2</sub> Sequestration*. Washington, DC, US
- <sup>139</sup> Supap, T., R. Idem, et al. (2001). "Kinetics of the Oxidative Degradation of Aqueous Monoethanolamine in a Flue Gas Treating Unit." *Industrial & engineering chemistry research* **40**(16): 3445-3450.
- <sup>140</sup> Supap, T., R. Idem, et al. (2006). "Analysis of Monoethanolamine and Its Oxidative Degradation Products during CO<sub>2</sub> Absorption from Flue Gases: A Comparative Study of GC-MS, HPLC-RID, and CE-DAD Analytical Techniques and Possible Optimum Combinations." *Industrial & engineering chemistry research* **45**(8): 2437-2451
- <sup>141</sup> Millward, A. R. and O. M. Yaghi (2005). "Metal-organic frameworks with exceptionally high capacity for storage of carbon dioxide at room temperature." *Journal of the American Chemical Society* **127**(51): 17998-17999
- <sup>142</sup> Babarao, R. and J. W. Jiang (2008). "Molecular screening of metal-organic frameworks for CO<sub>2</sub> storage." *Langmuir* **24**(12): 6270-6278
- <sup>143</sup> Hunt, J. R., C. J. Doonan, et al. (2008). "Reticular synthesis of covalent organic borosilicate frameworks." *Journal of the American Chemical Society* **130**(36): 11872-11873
- <sup>144</sup> Banerjee, R., A. Phan, et al. (2008). "High-throughput synthesis of zeolitic imidazolate frameworks and application to CO<sub>2</sub> capture." *Science* **319**(5865): 939-943
- <sup>145</sup> Wong-Foy, A. G., A. J. Matzger, et al. (2006). "Exceptional H<sub>2</sub> Saturation Uptake in Microporous Metal-Organic Frameworks." *J. Am. Chem. Soc.* **128**(11): 3494-3495
- <sup>146</sup> Siriwardane, R., M. Shen, et al. (2004). "CO<sub>2</sub> Capture Utilizing Solid Sorbents." *Third Annual Conference on Carbon Capture and Storage, Alexandria, Virginia*
- <sup>147</sup> Xu, X. C., C. S. Song, et al. (2003). "Preparation and characterization of novel CO<sub>2</sub> "molecular basket" adsorbents based on polymer-modified mesoporous molecular sieve MCM-41." *Microporous and Mesoporous Materials* **62**(1-2): 29-45.
- <sup>148</sup> Gray, M. L., Y. Soong, et al. (2005). "Improved immobilized carbon dioxide capture sorbents." *Fuel Processing Technology* **86**(14-15): 1449-1455
- <sup>149</sup> Sjostrom, S. (2010). "Post-combustion CO<sub>2</sub> Control Using Solid Sorbents: Results from 1 kW Pilot Tests." *9th Annual Conference on Carbon Capture and Sequestration, Washington, USA. May 10 - 13th.* Available from <http://www.netl.doe.gov/technologies/coalpower/ewr/co2/pubs/5649%20CCS%20Conference%20May%202010.pdf>.
- <sup>150</sup> Brandani, S. (2010). "Innovative Gas Separations for Carbon Capture Consortium". Grant agreement available from <http://gow.epsrc.ac.uk/ViewGrant.aspx?GrantRef=EP/G062129/1>.
- <sup>151</sup> Drage, T. C. (2010). "Step Change Adsorbents and Processes for CO<sub>2</sub> Capture. Grant agreement available from <http://gow.epsrc.ac.uk/NGBOViewGrant.aspx?GrantRef=EP/G061785/1>.
- <sup>152</sup> ADA (2011). "ADA Environmental Solutions website. <http://www.adaes.com/carbon/co2/>. Accessed 8/5/2011
- <sup>153</sup> Krutka, H. (2011). "A Solid Retrofit Approach for Capturing CO<sub>2</sub>: Pilot Testing and Equipment. Electric Utilities Environmental Conference - Phoenix, AZ - January 31, 2011.
- <sup>154</sup> Pennline, H. W. H., J.S. Gray, M.L.. Siriwardane, R.V. Fauth, D.J. and Richards.G.A. (2009). NETL In-house Post combustion Sorbent-Based Carbon Dioxide Capture Research. Annual IEP Contractors Meeting
- <sup>155</sup> Sjostrom, S. and H. Krutka (2010). "Evaluation of solid sorbents as a retrofit technology for CO<sub>2</sub> capture." *Fuel* **89**(6): 1298-1306

### 2.3.3 Post-combustion capture: Ionic liquids

Ionic liquids (ILs) are most commonly defined as salts that have low (less than 100°C) melting points and which are thus often liquid at room temperature. Historically, ionic liquids have been researched for a range of applications such as thermal batteries and as replacements for organic solvents in organic synthesis and other areas of analytical chemistry. ILs have a number of characteristics that make them interesting as potential “designer” solvents, namely:

- Negligible vapour pressure
- High thermal and chemical stability
- Non-flammable
- Tunable miscibility with organic solvents and water
- High, tunable solubility of a range of gases (e.g., CO<sub>2</sub>, SO<sub>2</sub>, H<sub>2</sub>S)

The low vapour pressure means that there is little risk of IL carry-over in processes, and, combined with the high thermal and chemical stability suggests that the process losses of the IL are likely to be small, although this remains to be proven in real industrial conditions. In addition, the high thermal and chemical stability of ILs allows for a wide range of process conditions so that, for instance, high pressure or temperature desorption may be possible, creating potentially interesting opportunities for process optimisation.

#### *Development aspects and prospects*

##### *Key drivers and issues for development*

Although their use is still in an early stage, ILs have begun to find applications in a separation technology for instance in liquid chromatography, as extraction solvents and in other aspects of analytical chemistry.<sup>156</sup>

Early research on the use of ILs for the capture of CO<sub>2</sub> showed that, by coupling atomistic modelling with experimental synthesis and testing, the solubility of CO<sub>2</sub> could be increased by a factor of 40 or more (relative to the IL with the highest CO<sub>2</sub> solubility that could be identified at the project start) by tuning the physical solubility and adding chemical functionality to the ILs.<sup>157</sup> However, others have pointed out that while the molar solubility of CO<sub>2</sub> in ILs is high, the volumetric solubility—which is the more relevant engineering parameter—is lower than that of most organic solvents due to the high molecular weight of the ILs. In practice it seems ILs exhibit higher CO<sub>2</sub> solubility than most polymers but lower solubility than most organic solvents.<sup>158</sup> Because of this, hybrid solutions using mixtures of ILs and amines have also been proposed as these can potentially reduce the energy penalty of pure amine systems.<sup>158</sup> Indeed, a DoE-funded demonstration project discussed below is for just such a hybrid system.

In addition to CO<sub>2</sub>, ILs can also demonstrate relatively high solubility for other gaseous species<sup>157</sup> such as SO<sub>2</sub>, raising the possibility that IL systems could be used to capture multiple flue gas components simultaneously. However, due to their relatively early stage of development, the robustness of ILs in a flue gas environment is still to be determined. It is not clear if, for instance, spikes in fly ash or other flue gas components could poison ILs.<sup>163</sup> Longer duration testing is required.

### ***Implications of retrofitting to an existing power plant***

As with other post-combustion capture technologies, ILs would be applicable for downstream use with coal and biomass combustion systems. The set of retrofit considerations are likely to be similar to those for amine scrubbing, although ionic liquids due to their high solubility have the potential to occupy much a smaller equipment footprint than amine systems, and hence retrofitting may be easier.

### ***Technology Readiness Level, pilot plants***

Current TRL is 2-3, "Analytical and experimental critical function and/or characteristic proof of concept". All current activities in ILs are at the lab-scale or below, with no pilot or demonstration plants using the technology yet constructed.

The US Department of Energy launched a bench-scale demonstration of ILs with ION Engineering and Xcel Energy in January 2010<sup>159</sup>. The objective of the project is to demonstrate ION Engineering IL-amine solvent and CO<sub>2</sub> capture process at bench scale (about 5 litre per minute flow rate, about 25 kW<sub>th</sub> equivalent<sup>160</sup>) using simulated flue gas in ION Engineering's labs followed by operation of a 5 to 15 litre per minute unit on actual flue gas (25-75 kW<sub>th</sub> equivalent<sup>160</sup>). The project is scheduled to be completed by December 2012. However, this particular testing program includes on the order of 72 hours of testing on real flue gas<sup>159</sup>, which is unlikely to be long enough to address issues regarding the durability of ILs in real industrial conditions.

Given the early stage of development and small scale of current IL testing, it seems unlikely that ILs will have matured beyond TRL 4-5 by 2020, a rate of maturation which would be consistent with that demonstrated by carbonate looping<sup>158</sup>.

### ***Main players internationally, UK capabilities***

There are a few start-ups that are focusing on ILs for CCS that appear to be spin-outs from Universities with IL research programs, e.g. ION Engineering (Colorado, USA) and Proionic GmbH (Austria). There are also start-ups such as IoLiTec (Heilbronn, Germany) and CLEA Technologies (the Netherlands) that are focused on other applications of ILs, such as heat transfer and storage media, and in nano-particle synthesis. Scionix (UK) focus on metal industry applications, and have only conducted lab-scale CO<sub>2</sub> absorption testing, which showed poor CO<sub>2</sub> uptake for choline chlorides.

In addition, the major chemicals companies are also clearly engaged in developing ILs for a wide range of applications – examples include BASF, BP Chemicals, Cytec Industries, Dupont, EMD Chemicals, KOEI Chemical Company, Merck and SACHEM<sup>161,162</sup>.

There are also a large number of IL research programmes at Universities, although these do not all focus on CCS or separation applications. Some examples include EPFL (Switzerland), Imperial College London (UK), Laval University (Canada), Queen's University of Belfast (UK), University of Notre Dame (USA), University of Leoben (Austria) and University of Colorado (USA). CSIRO (Australia) are also collaborating with Monash University, Melbourne to screen for ILs suitable for CCS applications.

### ***Environmental factors***

ILs usually have negligible vapour pressure and are chemical stable, hence is it expected that there will be minimal losses from the process cycle. Therefore, emissions to the atmosphere or risks to human health are expected to be very low in comparison to amine solvent scrubbing systems.

## ***Technical and economic characteristics***

### ***Efficiencies with and without capture***

ILs can exhibit lower heats of absorption than typical amine solvents<sup>163</sup> suggesting that IL systems will require less energy input for regeneration. One study found that ILs could reduce the regeneration energy requirement by 12 - 16% relative to a 30% MEA-based solvent.<sup>164</sup> While a second study estimated the energy losses associated with an IL capture system could be 16% lower than a commercial MEA process with capital costs being 11% lower.<sup>165</sup> And a third suggests that ILs could reduce the energy requirements by as much as 45% compared to aqueous amine system.<sup>159</sup> This process energy saving is potentially partly negated by the typically high viscosity of ILs which will result in increased circulation energy requirements and cost<sup>158</sup>.

### ***CO<sub>2</sub> capture rate***

CO<sub>2</sub> capture rates are expected to be around 90% (similar to amine systems), or possibly higher, but this is still to be verified in practice.

### ***Flexibility***

Operability is expected to be similar to that of amine systems, although this is clearly somewhat speculative at this stage<sup>157</sup>.

### ***Economics***

Currently the cost of ILs is very high—with small laboratory scale quantities costing on the order of \$1,000/kg<sup>161</sup>—as they are only synthesized in bench-scale quantities. For comparison, ionic liquids used in the preparation of electrolytes for dye-sensitized solar cells, are available in quantities up to 500 g and retail for prices in the range of \$11,000-15,000/kg<sup>166</sup>. However, there is every expectation that scale-up to production at larger scales will drive down costs significantly, although the reduction may not be sufficient to make them commercially viable for CO<sub>2</sub> capture<sup>158</sup>.

Early system studies conducted for the DoE by the University of Notre Dame<sup>157</sup> suggested that, even assuming significantly improved IL performance, IL flowrates of over 300,000 lpm would be necessary for capture at an approximately 300 MWe plant. This is consistent with the numbers provided by ION Engineering for their demonstration (flowrates of 5-15 lpm for a 25-75kWth equivalent system) suggesting that scale-up by 3 to 4 orders of magnitude from the currently planned demonstrations will be required for commercial use.

A recent presentation by ION Engineering gives a 27% increase in LCOE from adding ionic liquid capture, compared to a 53% increase in LCOE from adding an econamine system<sup>160</sup> – i.e. significant savings in capital and operating costs are expected in the future once the technology has been proven.

- 
- <sup>156</sup> Han and Row (2010) "Recent Applications of Ionic Liquids in Separation Technology", *Molecules* 15, 2405-2426; doi:10.3390/molecules15042405
- <sup>157</sup> US DoE NETL (2007) "Design and Evaluation of Ionic Liquids as Novel CO<sub>2</sub> Absorbents", available at: <http://www.netl.doe.gov/technologies/coalpower/ewr/co2/pubs/42122%20U.%20Notre%20Dame%20ionic%20liquids%20Final%20Report%20Sep%202007.pdf>
- <sup>158</sup> MacDowell et al. (2010) "An overview of CO<sub>2</sub> capture technologies", *Energy Environ. Sci.*, 2010, 3, 1645-1669, DOI: 10.1039/C004106H
- <sup>159</sup> US DoE NETL (2011) "Novel Solvent System for CO<sub>2</sub> Capture, Project Fact Sheet", available at: <http://www.netl.doe.gov/publications/factsheets/project/FE0005799.pdf>
- <sup>160</sup> Corkadel, C. (2010) "Novel Solvent System for CO<sub>2</sub> Capture", on behalf of Ion Engineering, at the Sept 2010 NETL CO<sub>2</sub> Capture Technology Meeting, available at: <http://www.netl.doe.gov/publications/proceedings/10/co2capture/presentations/wednesday/Claude%20Corkadel%20-%20ION%20Engineering%20LLC.pdf>
- <sup>161</sup> Chemical Industry Vision2020 (2004) "Accelerating Ionic Liquid Commercialization-Research Needs to Advance New Technology", available at: [http://www.chemicalvision2020.org/pdfs/ionicliquid\\_commercialization.pdf](http://www.chemicalvision2020.org/pdfs/ionicliquid_commercialization.pdf)
- <sup>162</sup> Congress On Ionic Liquids 4, Washington D.C., July 2011, <http://coil-4.org/>
- <sup>163</sup> EPRI (2007) "Assessment of Post-Combustion Capture Technology Developments", available at: <http://www.canadiancleanpowercoalition.com/pdf/AS20%20-%200000000000001012796%5b1%5d.pdf>
- <sup>164</sup> D. Wappel et al. (2010) "Ionic liquids for post-combustion CO<sub>2</sub> absorption", *International Journal of Greenhouse Gas Control* 4, 486-494
- <sup>165</sup> Shiflett et al. (2010) "Carbon Dioxide Capture Using Ionic Liquid 1-Butyl-3-methylimidazolium Acetate", *Energy Fuels*, 24 (10), pp 5781-5789
- <sup>166</sup> Solaronix (2011) "Ionic liquid price list", available at: <http://www.solaronix.com/products/ionicliquids/pricing.html>

### 2.3.4 Post-combustion capture: Enzymes

Enzymes are biological proteins that catalyse chemical reactions, significantly increasing reaction rates. Carbonic anhydrase (CA) is the most powerful catalyst known to accelerate the transformation of CO<sub>2</sub> to bicarbonate ions (HCO<sub>3</sub><sup>-</sup>) by up to 100,000 times naturally-occurring reactions. CA is naturally found in the blood of humans and other mammals, and facilitates the transfer of CO<sub>2</sub> during respiration.

By using CA within a suitable solvent, an absorption-regeneration cycle can be established, with CO<sub>2</sub> converted into bicarbonate ions in an absorber column, and converted back into CO<sub>2</sub> in the higher temperature regeneration column. This “industrial lung” concept is shown in Figure 2.14.

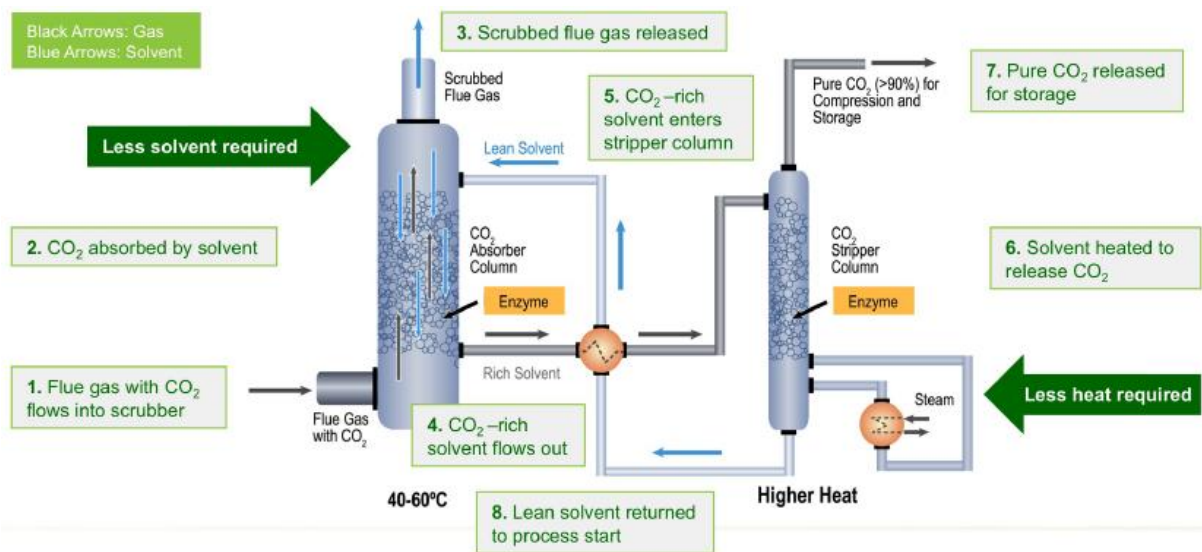

Figure 2.14: Enzyme-solvent regenerative cycle concept<sup>167</sup>

However, carbonic anhydrase as found in nature does not function in the high temperatures and harsh conditions of industrial power generation plants – “denaturing” (the permanent destruction of the protein structure) normally occurs at temperatures above 40°C. Enzyme stability can be increased by immobilising the enzyme within a protective polymer structure, which thereby extends its lifetime at high temperatures, whilst still catalysing the CO<sub>2</sub> to bicarbonate reaction.

CA enzymes have a number of characteristics that make them interesting as potential hybrid system using solvents, namely:

- Applying immobilised enzymes to existing capture solvents (such as MEA or MDEA amines) increases CO<sub>2</sub> removal rates, thereby allowing lower solvent volumes to be used
- In the presence of the enzymes, these solvents also require less heat to release CO<sub>2</sub> than standard amine solutions, hence parasitic loads are reduced

## ***Development aspects and prospects***

### ***Key drivers and issues for development***

Enzymes are used in the chemical industry and other industrial applications when extremely specific catalysts are required. However, enzymes in general are limited in the number of reactions they have evolved to catalyze and also by their lack of stability in organic solvents and at high temperatures.

To date, lab-scale testing of carbonic anhydrase has only managed to maintain enzyme stability at temperatures up to 75°C for 24 hours<sup>168</sup>, or maintain 80% activity for 120 days at 40°C<sup>169</sup>. However, durability for many thousands of hours will likely be required at temperatures above 100°C, as found in the solvent stripper.

Furthermore, due to their relatively early stage of development, the robustness of carbonic anhydrase enzymes in a flue gas environment is still to be determined. It is not clear if, for instance, fly ash, particulate matter, NO<sub>x</sub>, SO<sub>x</sub> or other flue gas components could poison or denature the enzymes – although in general, biological catalysts are more tolerant of contaminants than chemical catalysts.

CO<sub>2</sub> Solution have conducted a short trial of their lab-scale CO<sub>2</sub> capture prototype at the Quebec City, Canada waste incinerator. This test demonstrated that the enzyme functioned effectively and was stable in a real world environment. However, it is not clear if only the CO<sub>2</sub> absorption function was tested, or both CO<sub>2</sub> absorption and regeneration were tested. Longer testing of the whole capture system, and integration with power plants at larger scales is required to prove the robustness of the system to real-world flue gases.

### ***Implications of retrofitting to an existing power plant***

As with other post-combustion capture technologies, enzyme-solvent systems would be applicable for downstream use with coal and biomass combustion systems. The set of retrofit considerations are likely to be very similar to those for amine scrubbing, although due to their higher reaction rates, enzyme systems have the potential to occupy a much smaller equipment footprint than standard amine systems, and hence retrofitting may be easier. CO<sub>2</sub> Solution have estimated that the size of the absorption tower could be reduced by 90% by using enzyme-solvents<sup>170</sup>.

### ***Main players internationally, UK capabilities***

There are a couple of start-ups and university spin-offs that are focusing on using enzymes for CCS. One of the more advanced appears to be CO<sub>2</sub> Solution (Quebec, Canada). The industrial enzyme company Codexis (California, US) has invested in CO<sub>2</sub> Solution, and has a Joint Development Agreement to accelerate the technology. In May 2010, Codexis received \$4.7m in ARPA-E Recovery Act funding for the development of novel CCS technology. CO<sub>2</sub> Solution are using Cross Linked Enzyme Aggregate technology licensed from CLEA Technologies B.V. (Delft, the Netherlands). A previous collaboration between CO<sub>2</sub> Solution and The Babcock & Wilcox Co was terminated in 2008, with no pilot plant constructed.

Akermin (St Louis, US) are also developing an enzyme-solvent technology, CSIRO (Australia) has carried out lab-scale testing, as have the biotech firm, Novozymes<sup>171</sup>. There are also potential synergies with membrane technologies: Carbozyme (US) is developing an enzyme catalyzed, liquid membrane permeator<sup>172</sup>.



There are few research programmes at Universities, with only the University of Studies of Napoli “Federico II”, Italy<sup>173</sup>, appearing to carry out theoretical modelling of carbonic anhydrase CCS. There are no known industrial capabilities or academic activities in the UK.

### ***Technology Readiness Level, pilot plants***

Current TRL is 3, since all current activities in carbonic anhydrase are at the lab-scale or below, with no pilot or demonstration plants using the technology yet constructed.

Given the early stage of development and small scale of current enzyme testing, it seems unlikely that ILs will have matured beyond TRL 4-5 by 2020.

The aluminium manufacturer, Alcoa, announced a collaboration with Codexis and CO<sub>2</sub> Solution in April 2011<sup>174</sup>. With \$13.5m from the US DOE, this project is intended to devise solutions that treat and utilize a primary by-product of the aluminium manufacturing process known as alkaline clay, or bauxite residue, as well as other alkaline industrial residuals. After 3 years lab testing, a pilot plant is planned that will test a scrubbing process that combines treated flue gas, enzymes and alkaline clay to create a mineral-rich neutralized product that could be used for environmental reclamation projects. However, although this will be capturing CO<sub>2</sub>, this project is not primarily aimed at power generation applications.

### ***Environmental factors***

As enzymes are being proposed for use in hybrid systems with amine solvents, many of the health and environmental risks that apply to amine solvents, and their degradation products, will still apply. However, the lower solvent volumes should reduce risks to some degree. The human health aspects regarding the industrial use of carbonic anhydrase are not yet known.

### ***Technical and economic characteristics***

#### ***Efficiencies with and without capture***

Enzyme-solvent systems can exhibit lower heats of absorption than typical amine solvents suggesting that these hybrid systems will require less energy input for regeneration. Both Codexis/CO<sub>2</sub> Solution and Akermin have estimated that regeneration energy costs could be reduced by up to 30% compared to standard amine systems<sup>167,175</sup>. This would equate to a plant efficiency penalty of around only 7 %-points.

#### ***CO<sub>2</sub> capture rate***

CO<sub>2</sub> capture rates are expected to be around 90% (similar to amine systems), or possibly higher, but this is still to be verified in practice.

#### ***Flexibility***

Operability is expected to be similar to that of amine systems, although this is clearly somewhat speculative at this stage.

#### ***Economics***

The current cost of carbonic anhydrase enzymes is unknown. Given the low volumes of manufacture, with only small laboratory scale quantities synthesised so far, the costs are likely to be very high

(similar to Ionic Liquids). However, there is every expectation that scale-up to production at larger scales will drive down costs significantly (as with enzymes used for biofuels applications), although the reduction may not be sufficient to make them commercially viable for CO<sub>2</sub> capture.

Codexis have stated that future enzyme-solvent CO<sub>2</sub> capture systems could add only 35% to the capital costs of an unabated power plant<sup>176</sup>, as opposed to the 80% added by current amine scrubbing capture processes, however, this remains highly aspirational target.

---

<sup>167</sup> Codexis (2011) "Media Kit: Carbon Capture Workflow (with technical captions)" available at:

[http://www.codexis.com/pdf/carbon\\_capture\\_tech.pdf](http://www.codexis.com/pdf/carbon_capture_tech.pdf)

<sup>168</sup> Power Plant CCS (5 March 2011), "Enzyme based Carbon Capture reduces the energy requirement", available at:

<http://powerplantccs.com/blog/2011/03/enzyme-based-carbon-capture-reduces-the-energy-requirement.html>

<sup>169</sup> CO2 Solution, "Technology FAQ", accessed 16<sup>th</sup> June 2011, available at: <http://www.co2solution.com/en/technology-faq.php>

<sup>170</sup> CO2 Solution (23 June 2010) "CO2 Solution announces significant technical results" press release available at:

[http://www.co2solution.com/data/file\\_library/2010-06-23%20A-%20CO2%20Solution%20Announces%20Significant%20Technical%20Results.pdf](http://www.co2solution.com/data/file_library/2010-06-23%20A-%20CO2%20Solution%20Announces%20Significant%20Technical%20Results.pdf)

<sup>171</sup> Salmon, S., Saunders, P. and M. Borchert (2010) "Enzyme technology for carbon dioxide separation from mixed gases", Novozymes poster at Earth and Environmental Science 6 (2009) 172018, available at:

[http://iopp.fileburst.com/ees/ees9\\_6\\_172018.pdf](http://iopp.fileburst.com/ees/ees9_6_172018.pdf)

<sup>172</sup> Trachtenber et al. (2009) "Membrane-based, enzyme-facilitated, efficient carbon dioxide Capture", GHGT-9, Energy Procedia 1, 353–360, Available at:

<http://www.netl.doe.gov/technologies/coalpower/ewr/co2/pubs/43084%20Carbozyme%20membrane%20GHGT9%20nov08.pdf>

<sup>173</sup> Russo, M.E., Olivieri, G., Marzocchella, A., Napoli, F. and P. Salatino (2010) "Assessment of a novel carbon capture and storage process by carbonic anhydrasenext term treatment of flue gases", available at:

<http://www.sciencedirect.com/science/article/pii/S0168165610005900>

<sup>174</sup> CO2 Solution (7 April 2011) "Alcoa Unveils Partnership for Carbon Capture Technology Pilot Test that Turns Emissions into Beneficial Commercial Products", available at: [http://www.co2solution.com/data/file\\_library/2011-04-07%20Alcoa%20Unveils%20Partnership%20for%20Carbon%20Capture%20Technology%20Pilot%20Test.pdf](http://www.co2solution.com/data/file_library/2011-04-07%20Alcoa%20Unveils%20Partnership%20for%20Carbon%20Capture%20Technology%20Pilot%20Test.pdf)

<sup>175</sup> Akermin, "CO2 capture", accessed 16<sup>th</sup> June 2011, available at: [http://www.akermin.com/applications/co2\\_capture/](http://www.akermin.com/applications/co2_capture/)

<sup>176</sup> Aston, A. (4 May 2011) "xploring alternative ways to capture carbon using enzymes", available at:

<http://www.globalccsinstitute.com/community/blogs/authors/adamaston/2011/05/04/exploring-alternative-ways-capture-carbon-using-enzymes>

### 2.3.5 Post-combustion capture: Membrane separation of CO<sub>2</sub> from flue gas

Commercial gas membranes have been in existence for many decades, and are currently used for a wide range of gas separation processes. A basic schematic for the purpose of post-combustion CO<sub>2</sub> capture is shown in Figure 2.15. The membrane allows CO<sub>2</sub> to permeate through it, whilst other flue gas species (predominantly N<sub>2</sub>) may not pass through, thus providing a CO<sub>2</sub>-rich permeate stream for sequestration. Permeation through the membrane requires a pressure differential across the membrane, achieved by compression of the flue gas stream and/or use of a vacuum pump on the CO<sub>2</sub> permeate stream.

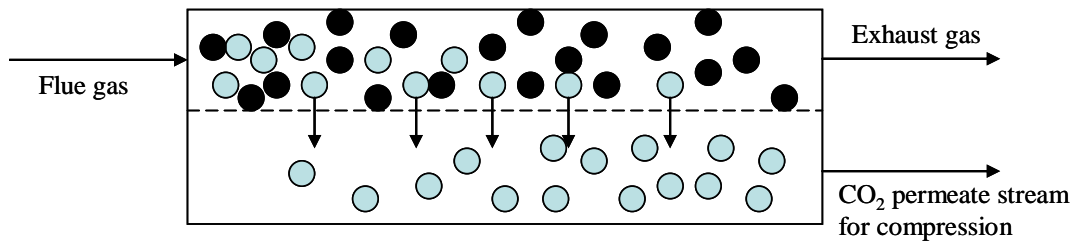

Figure 2.15: Schematic of membrane separation of CO<sub>2</sub> from flue gas

The performance of the membrane is based on optimisation of two key factors: the permeability (i.e. the rate at which gas may pass through the membrane) and the selectivity (in this case the purity of CO<sub>2</sub> in the resulting permeate stream). However, it has been shown by Robeson<sup>177</sup> that a trade-off exists between these two parameters, and that performance is limited by an upper bound shown in Figure 2.16. However, recent advances in membrane technology, as discussed later, have successfully crossed this upper bound.

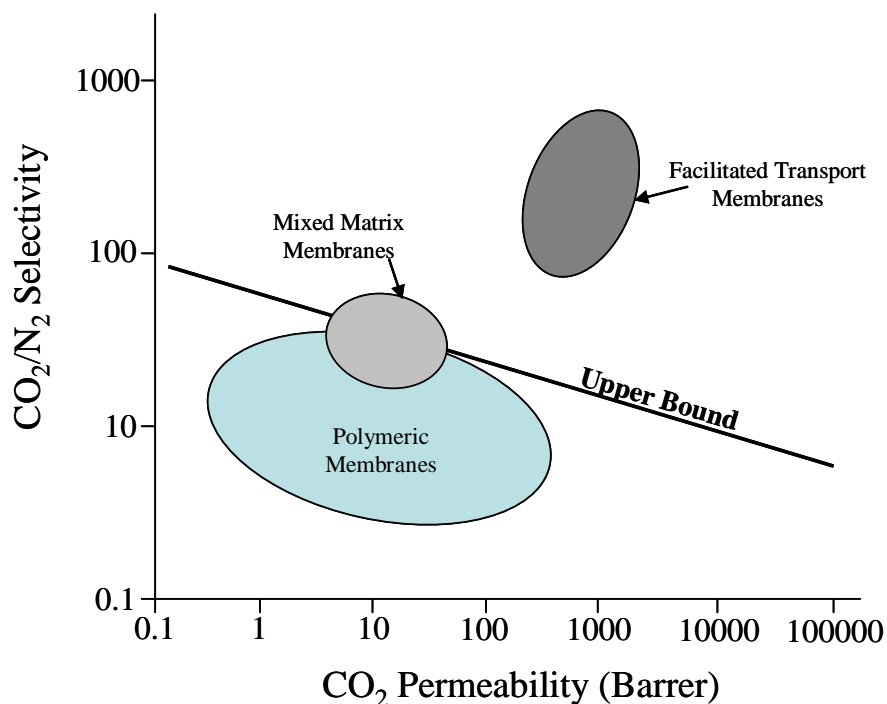

Figure 2.16: Performance of existing polymeric membranes, and Robeson's upper bound<sup>178</sup>

For post-combustion CO<sub>2</sub> capture, polymeric membranes are the most widely technology. These typically comprise a thin, non-porous, selective surface skin, upon a porous, non-selective support mechanism. Selective permeation of CO<sub>2</sub> through the outer skin occurs *via* solution-diffusion. Polymeric materials are typically polysulfones or polyimides, which provide good thermal and chemical durability, in addition to reasonable permeabilities and selectivities. Depending on the glass transition temperature of the polymer, the polymer may be rubbery or glassy, the former providing higher permeability, and the latter higher selectivity. Hence composite polymeric membranes, which carry the benefits of both glassy and rubbery polymers are becoming common.

There are numerous variations on polymeric membranes, within which significant performance advances are being made. Carbon membranes act as molecular sieves for CO<sub>2</sub>; they can withstand higher temperatures than normal polymeric membranes, and are capable of higher selectivities and permeabilities. However, producing a thin membrane is difficult, and hence the flux of CO<sub>2</sub> is generally lower; problems also arise from their relative brittleness and higher costs. Mixed matrix membranes comprise phases of inorganic particles within polymeric layers; their performance in CO<sub>2</sub> separation can exceed Robeson's upper bound. Perhaps the most promising membrane technologies are facilitated transport membranes, originally patented by General Electric<sup>179</sup>. These contain carriers -which may be mobile or fixed within the polymer matrix - which react with the CO<sub>2</sub> and transport it through a liquid membrane. Performance can be further enhanced by the inclusion of catalysts, pushing their CO<sub>2</sub> capture ability well above Robeson's upper bound. The relative performance of each technology, based on a 2007 review by Scholes *et al*<sup>178</sup>, is given in Figure 2.16.

Flue gas membrane separation of CO<sub>2</sub> is commonly compared against sorbent scrubbing as the most valid technology for post-combustion CO<sub>2</sub> capture. Whilst sorbent scrubbing is more widely favoured, the two technologies may be compatible through membrane gas absorption<sup>180</sup>, a technology where the flue gas and liquid sorbent phases are separated by a non-selective membrane. This separation of the two flows prevents potential foaming and flooding problems, and provides a high gas-liquid surface area, with the potential to substantially reduce the size of the equipment. Membrane separation may not be suitable for large-scale power generation, as there a significant questions over the permissible flowrate which may be efficiently handled by membrane technologies. Furthermore, since their performance is highly dependent on flue gas CO<sub>2</sub> concentration, membrane separation technologies may be better suited towards industrial applications, such as cement and steel production.

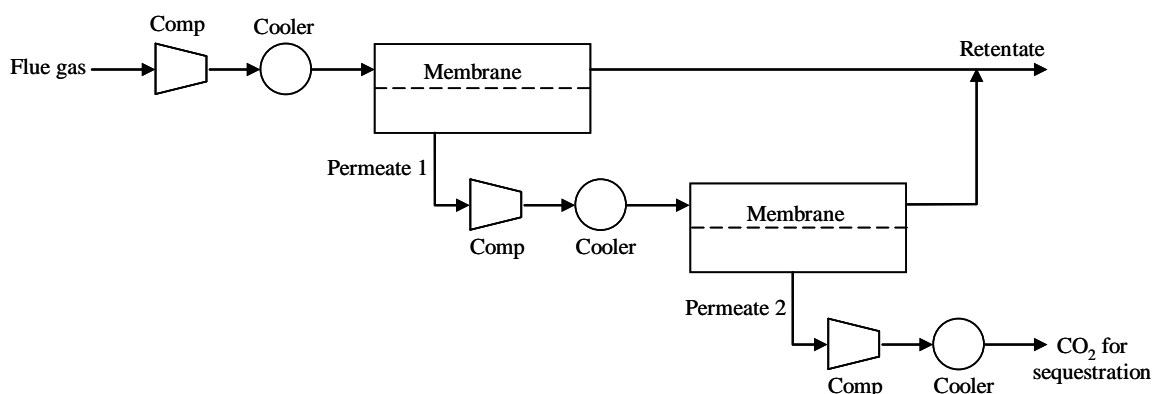

Figure 2.17: A two-stage membrane cascade for CO<sub>2</sub> separation

## ***Development aspects and prospects***

### ***Key drivers for development***

The continued development of amine sorbents may prove to be one of the key drivers for membrane separation technologies, given their potential compatibility in membrane gas absorption (although it should be noted that the membranes associated with this method are not nearly so advanced as dedicated polymeric membranes for CO<sub>2</sub> separation). Other similar applications for which both amine sorbents and membrane separation are applicable, such as the removal of CO<sub>2</sub> and other acidic gases from CH<sub>4</sub>, have also highlighted that membrane separation technologies can be highly competitive, at least on a performance basis<sup>181</sup> with amine sorbents; further development of these technologies may too provide a key driver for post-combustion membrane separation capture.

### ***Key development issues***

A number of key questions remain over its validity for CO<sub>2</sub> capture. A high selectivity is required to ensure a high purity CO<sub>2</sub> permeate stream; Van Der Sluijs *et al*<sup>182</sup> estimated a selectivity of at least 200 is necessary to make membrane technology competitive with sorbent scrubbing. At low CO<sub>2</sub> concentrations (< 10%), the driving force is small, and so higher pressures are required, potentially making the process both expensive and highly energy-intensive. Achieving high selectivity whilst retaining sufficient CO<sub>2</sub> permeability is problematic, and so there are questions over scale; for power generation applications, post-combustion flow-rates of 1,000 – 10,000 tonnes of gas/day can be expected, and may be beyond the capability of current membranes. There are also key unresolved issues with the various polymeric membrane technologies. Mixed matrix membranes, for instance, may foul rapidly due to the condensation of impurities. Facilitated transport membranes are unsuitable at temperatures above 100°C, due to evaporation of water within the membrane, and require regular rehydration. Whilst selectivity performance is typically quoted in terms of CO<sub>2</sub>/N<sub>2</sub>, the presence of other gas species within the flue gas must also be taken into account; the presence of un-burnt hydrocarbons, for instance, may cause plasticisation of the membrane.

### ***Implications of retrofitting to an existing plant***

Post-combustion membrane separation of CO<sub>2</sub> is suitable for retrofit. The associated equipment is likely to have lower space requirements than the scrubbing towers used for amine sorbents. The literature only considers the clean-up of flue streams produced from gas- or coal-burning power stations, but there is no reason why the technology would not be equally applicable to a wide range of biomass feedstocks.

However, due to the lower carbon content wt % for biomass compared to most coals, the associated vol % CO<sub>2</sub> in the flue gas will not be as high, which will potentially hinder the performance of the membrane. Co-firing with coal may therefore be necessary to raise the CO<sub>2</sub> content of the flue gas. Drying of the biomass to reduce moisture content will further increase CO<sub>2</sub> concentration. Due to the great emphasis on optimising CO<sub>2</sub>/N<sub>2</sub> selectivity with permeability, the effects of other gas species within the flue gas on membrane performance are not greatly understood. However, the lower sulphur content of biomass, with respect to coal, means that such issues are not likely to be as problematic for biomass.

### **Main international players**

The review carried out by Scholes *et al*<sup>178</sup> indicates a significant amount of R&D in the field, with a continual stream of patents on new membrane technologies. Many of the key players can be found in Europe, including TNO<sup>180,183</sup> and Utrecht University<sup>182</sup> (both in Holland), Institute of Energy Research (Germany)<sup>184</sup> and Norwegian University of Science & Technology<sup>185,186</sup>, as well as the Research Institute of Innovative Technology for the Earth (RITE) in Japan<sup>187,188</sup>.

Despite the considerable uncertainties surrounding the technology, recent years, the support of industrial players has seen the first demonstrations of post-combustion membrane separation. In 2007-2008, the first flue-gas demonstrations were carried out at the Rheinhafen steam power plant in Karlsruhe by German company EnBW; there are now plans to carry out 3000 hour tests on the structural integrity of the membranes<sup>189</sup>. Very recently, MEMFO (part of the Norwegian University of Science & Technology) have carried out a pilot-scale demonstration of post-combustion capture with a facilitated transport membrane<sup>190</sup>; industrial support has come from Statoil, Alstom and NFR. In the U.S, the Electric Power Research Institute (EPRI) are supporting a pilot demonstration of water and CO<sub>2</sub> removal from flue gas using membranes; operation will begin in 2012, with an expected capture rate of 20 tonnes CO<sub>2</sub>/day<sup>191</sup>.

### **UK activities and capabilities**

Both Imperial College and Newcastle University, with funding from the EPSRC, are carrying out research on ceramic membranes for CO<sub>2</sub> capture.

### **Technology Readiness Level**

Although membrane technology is proven for many applications, it remains an uncertainty for CO<sub>2</sub> capture; the recent emergence of pilot demonstrations, given in more detail later, means that a current TRL of 3-4. According to the IEA Clean Coal Centre<sup>192</sup> post-combustion membrane technologies are likely to take a back seat to the development and application of advanced amine solvents, and at best see commercialisation in tandem with solid sorbent technologies, and so a TRL of 5 may be expected by 2020.

### **Environmental Factors**

There are no environmental factors specifically regarding membrane technology. If used in conjunction with amine scrubbing e.g. membrane gas absorption, the conventional problems with solvent vaporisation and disposal apply.

### **Technical and economic characteristics**

#### **Equipment scales**

As previously discussed, the suitable scale of operation for membrane-separation technologies is of some debate, mainly due to the limited gas-handling rate. For a typical power plant, daily flow-rates of 1,000 - 10,000 tonnes of gas may be expected. Membranes used in natural gas treatment have been reported to have capacities of nearly 1,000 tonnes/day<sup>193</sup>; with continued development, it seems feasible that membrane-separation technologies may be suitable for large-scale power generation, e.g. 100's of MW in the future, but in the short-term may be better suited towards < 100 MW.

### ***Ability to load follow, flexibility***

As a method of post-combustion capture, the plant may continue to generate power in the case of failure of the membrane or its associated equipment (compressor, vacuum pumps etc). Membrane separation technology should not affect the plant's ability to load follow, although the CO<sub>2</sub> capture rate may be affected, depending on the permeability of the membrane.

### ***Plant efficiency with capture***

There is great variance on the reported parasitic loads associated with membrane separations, largely due to its sensitivity to both the desired level of CO<sub>2</sub> capture and acceptable CO<sub>2</sub> purity of the permeate stream. Efficiency penalties arise from the necessity to compress the flue gas and/or apply a vacuum to the permeate to enhance the driving force. Additional membrane stages will enhance performance, but will of course lead to greater energy penalties. As a reference point, amine sorbent technologies typically require an additional 4-6 MJ/kg CO<sub>2</sub> captured for regeneration of the sorbent, with an associated plant efficiency penalty of 8-14 %-points including CO<sub>2</sub> compression. Although no data from the recent pilot demonstrations could be found, numerous parametric analyses have been carried out.

For a single-stage membrane analysis Kotowicz *et al*<sup>194</sup> estimated the power required by a vacuum pump was 7.5 % of the plant's power output; with 90 % CO<sub>2</sub> capture at 85 % purity, the plant efficiency losses (including CO<sub>2</sub> compression to 150 bar) were 15.4 %-points, but could be reduced to 8 %-points with further plant optimisation. Zhao *et al*<sup>9</sup> also assumed a single membrane stage and estimated a 3.23 %-point penalty (prior to compression), achieving 90 % capture at 80 % purity; it was admitted that for higher purities and capture rates, a single membrane stage was insufficient. Parametric studies carried out by Favre *et al* for single<sup>197,195</sup> membrane stages considered higher CO<sub>2</sub> concentrations (up to 30 mol %) to highlight the technology's potential in industrial applications such as steel and cement production. To achieve both capture rates and permeate purities of 80 % in a flue gas containing 10 vol % CO<sub>2</sub> (i.e. typical of a coal power plant), energy requirements of 8 MJ/kg CO<sub>2</sub> were required, higher than those of amine sorbents; furthermore, a CO<sub>2</sub>/N<sub>2</sub> selectivity of >100 would be essential.

However, for flue gases containing 20 vol % CO<sub>2</sub>, selectivities of only 40 or so were required, and the energy requirements fell substantially to 0.5-1 MJ/kg CO<sub>2</sub>. Hussain and Hägg<sup>185</sup> considered both single- and two-stage facilitated transport membranes for high flue-gas flowrates at 10 % CO<sub>2</sub> concentration. They confirmed that 90 % capture and purity could not be achieved with a single stage, but could be achieved by a two-stage membrane cascade, whilst maintaining energy demands below 4 MJ/kg. In addition, the performance of the facilitated-transport membranes was enhanced by introducing a sweep flow of steam, which aided the removal of CO<sub>2</sub> from the permeate side of the membrane.

The scope of the work so far therefore seems to suggest that with the current level of membrane technology, energy requirements are similar to those for amine sorbent methods, but may be reduced considerably in the future with more selective membranes.

### ***CO<sub>2</sub> capture rate***

The performance of membranes is highly sensitive to the flue-gas composition. Concentrations of CO<sub>2</sub> in flue-gas might be expected to be 3-15 % by mole fraction<sup>193,196</sup>, with the majority of the

remaining gas comprising N<sub>2</sub>. Higher concentrations provide a greater driving force for CO<sub>2</sub> capture. It is generally accepted that in order to achieve both sufficiently high CO<sub>2</sub> capture and CO<sub>2</sub> purity (both 90 + %), a single membrane stage is inadequate, and a multi-stage cascade, such as that shown in Figure 2.17 is required<sup>182,184,197</sup>. For a flue gas stream containing 14 mol % CO<sub>2</sub> from a 600 MW<sub>e</sub> plant, Van Der Sluijs suggested that a membrane CO<sub>2</sub>/N<sub>2</sub> selectivity of at least 200 would be required<sup>182</sup>. However, since the date of this publication (1992), great advances have been made, and membranes with CO<sub>2</sub>/N<sub>2</sub> selectivities as high as 230 and 400 have been reported<sup>187,188</sup>. Furthermore, in a more recent parametric analysis by Favre, > 90 % capture and CO<sub>2</sub> purity was achieved for a flue gas stream containing 10 mol % CO<sub>2</sub><sup>197</sup>. Based on these figures, it can be expected that CO<sub>2</sub> capture rate for membranes may be comparable to other post-combustion technologies such as amine and solid sorbents (albeit at lower purities of CO<sub>2</sub> in the captured stream), but inferior to technologies such as oxy-fuel and CLC.

### **Economics**

Limited data on cost analysis could be found. Costs on a per kg CO<sub>2</sub> basis calculated by Van Der Sluijs *et al*<sup>5</sup> were not particularly favourable, estimating \$ 48/tonne CO<sub>2</sub> for 75 % capture and only 50 % purity achieved by a single cascade, rising to \$71/tonne CO<sub>2</sub> for a two-stage cascade with 90 % purity and 95 % purity; however, these figures are from 1991, and are probably not valid for the significantly more selective membranes which have since been developed. Hussain and Hägg used a reference flue-gas processing cost of \$1.71/MSCF (thousand standard cubic feet) for a standard coal plant using Econamine FG sorbent, and found that costs as low as \$ 0.85/MSCF could be achieved with a two-stage membrane cascade. Assuming standard conditions of 25°C, and 1 atmosphere pressure, 1 MSCF is equivalent to 50.94 kgCO<sub>2</sub>, hence \$1.71/MSCF = £21.1/tCO<sub>2</sub>, and \$ 0.85/MSCF = £10.5/tCO<sub>2</sub>, for the flue-gas processing cost.

The costs were substantially lowered by increasing the pressure ratio across the membrane, since this greatly reduces the required membrane surface area (estimated to cost \$5/ft<sup>2</sup>, with an annual replacement cost of \$3/ft<sup>2</sup>). More costing data is required, but early indications are that the technology is affordable.



- 
- <sup>177</sup> Robeson LM. Correlation of separation factor versus permeability for polymeric membranes. *Journal of Membrane Science* 1991;62(2):165-185
- <sup>178</sup> Scholes CA, Kentish SE, Stevens GW. Carbon dioxide separation through polymeric membrane systems for flue gas applications. *Recent Patents on Chemical Engineering* 2008;1:52-66
- <sup>179</sup> Diffusion Barriers for Gas Separation. U.S. Patent GB1076438, 1967
- <sup>180</sup> Feron PHM, Jansen AE. Capture of carbon dioxide using membrane gas absorption and reuse in the horticultural industry. *Energy Conversion and Management* June;36(6-9):411-414.
- <sup>181</sup> Hao J, Rice PA, Stern SA. Upgrading low-quality natural gas with H<sub>2</sub>S- and CO<sub>2</sub>-selective polymer membranes: Part i. Process design and economics of membrane stages without recycle streams. *Journal of Membrane Science* 2002;209(1):177-206
- <sup>182</sup> Van Der Sluijs JP, Hendriks CA, Blok K. Feasibility of polymer membranes for carbon dioxide recovery from flue gases. *Energy Conversion and Management* May;33(5-8):429-436.
- <sup>183</sup> Feron PHM, Jansen AE. CO<sub>2</sub> separation with polyolefin membrane contactors and dedicated absorption liquids: performances and prospects. *Separation and Purification Technology* 2002;27(3):231-242
- <sup>184</sup> Zhao L, Riensche E, Menzer R, Blum L, Stolten D. A parametric study of CO<sub>2</sub>/N<sub>2</sub> gas separation membrane processes for post-combustion capture. *Journal of Membrane Science* 2008;325(1):284-294
- <sup>185</sup> Hussain A, Hägg M-B. A feasibility study of CO<sub>2</sub> capture from flue gas by a facilitated transport membrane. *Journal of Membrane Science* 2010;359(1-2):140-148
- <sup>186</sup> Hägg M-B, Lindbråthen A. CO<sub>2</sub> capture from natural gas fired power plants by using membrane technology. *Industrial & Engineering Chemistry Research* 2005;44(20):7668-7675
- <sup>187</sup> Kouketsu T, Duan S, Kai T, Kazama S, Yamada K. PAMAM dendrimer composite membrane for CO<sub>2</sub> separation: formation of a chitosan gutter layer. *Journal of Membrane Science* 2007;287(1):51-59
- <sup>188</sup> Duan S, Kouketsu T, Kazama S, Yamada K. Development of PAMAM dendrimer composite membranes for CO<sub>2</sub> separation. *Journal of Membrane Science* 2006;283(1-2):2-6
- <sup>189</sup> EnBW Energie (2010) "2010 innovation report" Accessed online 05/05/2011: [http://www.enbw.com/content/en/group/\\_media/\\_pdf/innovation\\_report\\_2010.pdf](http://www.enbw.com/content/en/group/_media/_pdf/innovation_report_2010.pdf)
- <sup>190</sup> Hussain A, Kim T, Hägg M. CO<sub>2</sub> capture from post combustion gas by employing membrane technology- a techno-economical analysis based on experimental pilot results. Abstract for IEAGHG 1<sup>st</sup> Post Combustion Capture Conference Abu Dhabi 2011
- <sup>191</sup> Water resource management: Concepts and challenges for the electricity sector & EPRI response. EPRI 2011
- <sup>192</sup> IEA Clean Coal Centre (2011) "Profiles: Post-combustion carbon capture - solid sorbents and membranes", Accessed online 05/05/2011: [http://www.iea-coal.org.uk/publishor/system/component\\_view.asp?LogDocId=82123&PhyDocID=7094](http://www.iea-coal.org.uk/publishor/system/component_view.asp?LogDocId=82123&PhyDocID=7094)
- <sup>193</sup> Dortmund D, Doshi K. CO<sub>2</sub> removal membrane technology: recent development. *Chemical Engineering World* 2003;38(9):55-66
- <sup>194</sup> Kotowicz J, Chmielniak T, Janusz-Szymanska K. The influence of membrane CO<sub>2</sub> separation on the efficiency of a coal-fired power plant. *Energy* 2010;35(2):841-850
- <sup>195</sup> Bounaceur R, Lape N, Roizard D, Vallieres C, Favre E. Membrane processes for post-combustion carbon dioxide capture: a parametric study. *Energy* 2006;31(14):2556-2570.
- <sup>196</sup> Herzog HJ. What future for carbon capture and sequestration? *Environmental Science & Technology* 2001;35(7):148-153
- <sup>197</sup> Favre E. Carbon dioxide recovery from post-combustion processes: can gas permeation membranes compete with absorption? *Journal of Membrane Science* 2007;294(1-2):50-59.

### 2.3.6 Post-combustion capture: High-temperature solid sorbents

Calcium (Ca) looping is a post combustion CO<sub>2</sub> capture technology relying on the reversible calcination of CaCO<sub>3</sub>, limestone. An example flowsheet of the technology is below, in Figure 2.18.

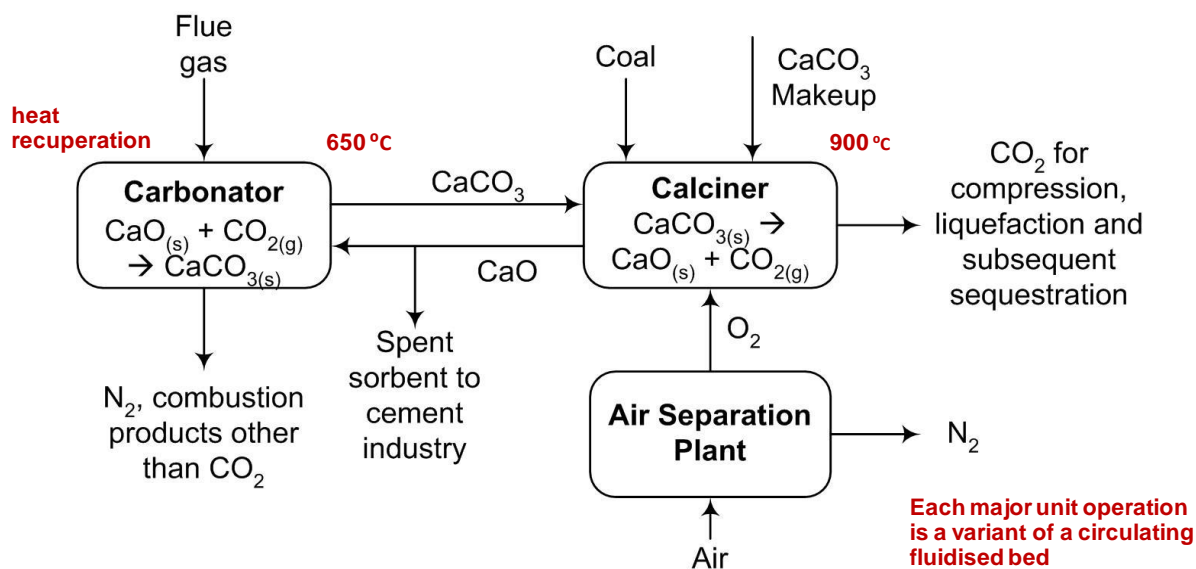

Figure 2.18: One potential variant of post combustion Ca looping

The flue gases from the power station enter the carbonator, where reaction I is effected:



Owing to the exothermic nature of reaction (I), heat is given out. The equilibrium thermodynamics (which are followed in this system) are such that reaction (I) occurs for temperatures below around 770°C for a partial pressure of CO<sub>2</sub> in the gas stream of approximately 0.15 bar. In general<sup>198</sup>, the reaction is conducted at a temperature of 650 – 700°C, sufficiently high that the heat from the reaction can be used within a standard steam cycle, a key reason why this process is more efficient than amine scrubbing.

The exhausted air from the carbonator, now stripped of CO<sub>2</sub>, passes out of the reactor, and is vented, after appropriate heat recovery. The CaCO<sub>3</sub> which is formed in the carbonator is transported to the calciner, which is heated to 900 – 950°C by combustion of coal or biomass (this can be a substantial fraction of the fuel added to the process, between 30 and 40 %). In order to produce a pure stream of CO<sub>2</sub> from the calciner, it is necessary to conduct the combustion with O<sub>2</sub> as opposed to air (unless an indirect heating method is used). One advantage of this technology as opposed to standard oxy-fuel combustion is that the air separation unit (ASU) is around 1/3 the size of that for the oxy-fired case.

Figure 2.19 shows the interconnected double circulating fluidised bed design for the CaOling 2MW<sub>th</sub> pilot plant<sup>199</sup>

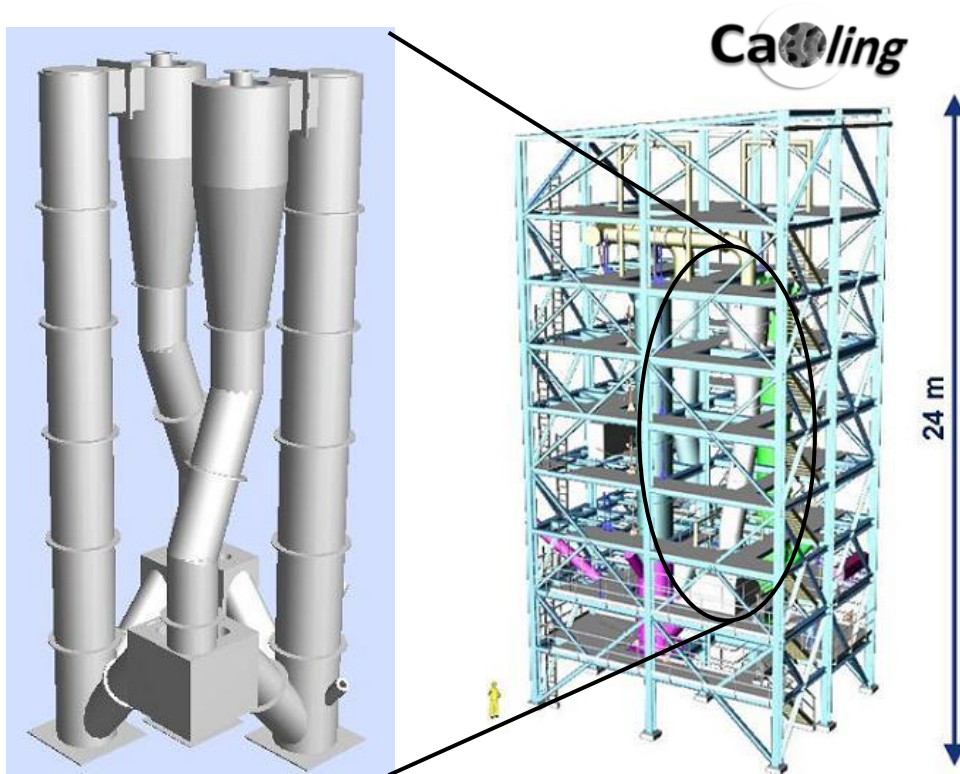

Figure 2.19: Design of the 2MW<sub>th</sub> CaOling pilot plant

One problem with Ca looping is that the ability of the limestone to react with CO<sub>2</sub> diminishes as the material is cycled from the calcined to carbonated form. Thus, on the first cycle, the CaO takes up around 0.8 moles of CO<sub>2</sub> per mole of CaO, whereas after 20 cycles the reactivity has reduced to a long term reactivity of around 0.08 moles / mole. It should be noted that even when fully degraded, the limestone retains a greater reactivity in grams of CO<sub>2</sub> taken up per gram of sorbent (roughly 0.157 g/g vs 0.132 g/g) than that of supported amine sorbents<sup>198</sup>.

In order to maintain a high reactivity in the system, and owing to the cheap and generic nature of the sorbent (crushed rock) a large purge flow can be maintained (though recent advances at Imperial College, currently in the process of patenting, have more than doubled the long term reactivity of the limestone). This purge flow is actually a benefit to the system, particularly when capturing CO<sub>2</sub> from a cement works, because CaCO<sub>3</sub> is the major constituent of cement (the production of which is responsible for around 4 – 5 % of anthropogenic CO<sub>2</sub> production globally). The initial calcination of lime is responsible for around 50 % of the CO<sub>2</sub> emissions from the cement industry – taking a purged stream of CaO from the calciner in the Ca-looping process would thus eliminate a substantial proportion of the CO<sub>2</sub> emissions from cement manufacture, in addition to decarbonising the power industry. Recent work examining the potential for this synergy<sup>200</sup> has not shown any significant issues with this utilisation.

### ***Development aspects and prospects***

#### ***Equipment scales***

Circulating fluidised beds are a mature technology, with units for power generation operating at utility scale. The JEA Northside Generating Station, in Jacksonville, Florida operates two units, each of 297.5 MWe<sup>201</sup>, and Poludniowy Koncern Energetyczny (PKE) operates a 460 MWe supercritical

circulating fluidised bed combustor<sup>202</sup>, supplied by Foster Wheeler. Indeed, the IEA reports<sup>203</sup> that there are plans in both Europe and China to develop 800 MWe CFBC units.

Approximately 30 - 40 % of the fuel in a power station would need to be burned in the calciner of a power station<sup>204</sup> equipped with Ca looping, indicating that PCC plants of ~ 1 GWe could be served by such a calciner. There are therefore no issues with maximum plant size. At the minimum scale, the two 1 – 2 MW<sup>th</sup> demonstration units currently under construction, which will not have external heating, indicate that there is no significant issue with small-scale operation.

### **Technology Readiness Level**

It is our assessment that the TRL level of Ca looping is between 4 (component and/or partial system validation in a laboratory environment) and 5 (Component and/or partial system validation in a relevant environment). Some components (i.e. CFB combustion boilers) have been validated in a working environment, though not in precisely the same setting as for Ca looping. Large laboratory scale tests have been ongoing since 2003<sup>205</sup> in Canada (75 kW<sub>th</sub>, semi-continuous), and more recently in Germany<sup>206</sup> (10 kW<sub>th</sub>, continuous) and Spain<sup>207</sup> (30 kW<sub>th</sub>, continuous dual CFB). The Spanish tests demonstrated CO<sub>2</sub> capture between 70 and 97 %, depending upon the conditions of operation. A full description of these rigs is available in a recent publication<sup>208</sup>. The biggest demonstrations of Ca looping are currently taking place in Darmstadt, Germany<sup>209</sup> and the La Pereda power plant, Asturias, Spain, as part of the EU CaOling project<sup>210, 211</sup>, both at the scale of 1 – 2 MW<sub>th</sub>. The CaOling project, with UK involvement from Imperial College, is fitted to a slip stream from an existing 50 MW<sub>e</sub> CFB boiler, owned by Hunosa. Some of the main inputs to the pilot plant are detailed in Table 2.11. Construction of the CaOling pilot plant is due for completion in summer 2011.

**Table 2.11: Design variables for the EU CaOling pilot plant**

Variable	Units	Value
Flue gas flow to carbonator	kg/hr	680 – 2,300
Maximum coal flow to calciner	kg/hr	325
Maximum fresh limestone flow	kg/hr	300
Oxygen flow to calciner	kg/hr	300 – 600
CO <sub>2</sub> flow to calciner	kg/hr	700 – 2,250
Air flow to calciner	kg/hr	600 – 2,500

The next stage of the CaOling program will be scale-up to 30 MWe size, provided that the pilot scale rig demonstrates sufficient controllability and flow stability. This should be completed well before 2020, and as discussed above it is likely that the final stage of scale-up, to utility scale, will be significantly easier than that for solvent-based scrubbing technology. There are a number of reasons why this is the case, not just the reduction in relative efficiency penalty, but also the lack of any environmentally detrimental waste product stream, discussed below. The fact that there are multiple demonstrations at the MW scale also mitigates in favour of rapid development, though to really push the technology forwards, demonstration at the tens of MW scale could be brought forwards. The TRL would therefore be likely to be level 5 to 6 by 2020.

### ***Key development issues***

There are a number of potential issues which are currently being investigated. All pilot plants currently run using standard, unmodified limestone as a sorbent. Current development priorities, which will be discussed in turn, are:

- Demonstration of the technology at scale. Issues for potential investigation include attrition of the limestone particles in large CFB systems, confirming the hydrodynamics and reaction rates within the system and ensuring that the loop seals between the two CFB reactors work as expected at large scale
- Currently, the technology is not as efficient as it could be, owing to the degradation of the sorbent, as discussed above
- The integration of the purged stream of limestone with cement manufacture has not been fully demonstrated
- It is possible that the combustion of biomass in the calciner may be undesirable, limiting the total biomass burned to 60 -70 %
- The technology is not understood well by industry outside parts of continental Europe and to a lesser extent the USA

The technology risk for Ca looping is relatively low, being based on a well understood CFB system. Scale-up is proceeding at a rapid pace. However, the interconnection of two circulating fluidised beds is not current industry practice, and could lead to issues with controllability. This has not been found to be a problem in laboratory-scale testing, though care is necessary to ensure that the loop seals remain fluidised and full. The hydrodynamics are also an area of current study. One potential problem is attrition of particles in the CFB environment – limestone is more friable than sand (usually used in CFBs), and is particularly friable when in the calcined form. There is evidence from pilot scale testing<sup>212</sup> that a self-limiting particle diameter of around 80 – 100  $\mu\text{m}$  is reached after intense attrition of the particles in the first few cycles (in fact, there is both attrition and densification of the particles – the work of Wu et al<sup>213</sup> demonstrates this).

As discussed above, degradation of the lime sorbent reduces the efficiency of the system. The results in table 2 are all for calculations based solely on limestone degrading according to a well accepted degradation equation<sup>214</sup>, or a slight modification<sup>215</sup>. Recent work<sup>216,217,218,219</sup> indicates that there are a large number of different ways to enhance the reactivity of the Ca for Ca looping. The effect of enhancing the long term reactivity by reaction of the initial limestone with acetic acid (a preactivation technique) has been studied<sup>220,221</sup> and it has been shown that approximately doubling the long term reactivity of the limestone towards  $\text{CO}_2$  reduces the energy requirement of the calciner by ~ 18 % by reducing the amount of unreacted material looping around the system.

It is crucial that the link between cement manufacture and Ca looping is adequately proven. This link, with the potential to decarbonise the power industry and substantially decarbonise cement manufacture, is one key advantage of the Ca looping process<sup>222,198</sup>. This synergy has recently been tested<sup>200</sup>; no significant problems were found with the use of spent sorbent in cement production, though the work is still in its early stages. Table 3 shows the Coal-fired capacity, cement production and cement production if the Ca looping cycle were to be added to all coal-fired capacity. These figures were calculated for standard limestones and do not take into account either gas-fired capacity or the potential for reactivation of spent sorbent to reduce the total purge stream, which

has been optimised only for the power cycle and not taking into account the potential for minimisation of the purge. It is clear that the UK would struggle to utilise all of the CaO if the looping cycle were to be fitted to all coal-fired capacity without consideration of minimising the purge. As discussed above, there are many methods currently under investigation to slightly modify the characteristics of the limestone and to reduce the required purge.

**Table 2.12: Global coal-fired capacity, cement production and cement production with looping cycle on all coal-fired capacity<sup>198</sup>**

Region	Coal-fired Capacity (GW)	Current Cement Production (Mtonnes/yr)	Cement Production with Looping Cycle on all Coal-fired Capacity (Mtonnes/yr)
UK	27	12.5	33
US	313	96.5	391
China	384	1350	470

The use of biomass in the calciner, where 30 – 40 % of the fuel is burned, is clearly advantageous for Ca looping in the context of biomass CCS. If it were not found to be possible to use biomass in the calciner, this would effectively limit the fraction of biomass combusted. Work is ongoing in this area – some preliminary investigations have been conducted which indicated that the rate of deactivation of the limestone might be enhanced somewhat by combustion of biomass, though these findings have not yet been published.

There is a further possibility, which has recently been investigated<sup>223</sup> – the combustion of biomass in the carbonator of the dual fluidised bed system, with *in situ* capture of the CO<sub>2</sub> produced. This is possible because of the low temperature (~ 700°C) at which biomass will burn, combined with the catalytic properties of CaO, which help to prevent large amounts of CO and tar forming at this low temperature. Thus, at a small scale, it is possible to envisage a standalone unit burning biomass without the requirement for a separate boiler, significantly reducing the capital cost of new build units. So far, three different types of biomass have been used in this context, sawdust, crushed olive stones and wood pellets (the exact type of wood is not mentioned). It should be noted that CFBs are already in use for combustion of biomass, mainly in the Nordic countries. For example, Brista Kraft, a 122 MW CFB plant near Stockholm, consisting of two CFBs, was activated in January 2003<sup>224</sup>.

### **Environmental factors**

There are two major potential issues related to Health and Safety. Firstly, the presence of large quantities of CaO, which is highly caustic, and secondly the presence of the air separation unit and the use of pure oxygen. The CaO which is produced should be disposed of into cement manufacture, with a purge set depending upon local demand (though a purge rate of 3 – 4 % is optimal, the system can tolerate a reasonably large variation in purge rate without vast implications on the plant efficiency. If there is no local capability to take the purged material, it can be reactivated via a hydration mechanism and fed back into the plant<sup>225,226</sup>, though this loses some of the synergy with cement manufacture.

### ***Main players internationally, UK capabilities***

The main academic groups researching Ca looping worldwide are at **Imperial College** (UK), Cambridge (UK), Cranfield (UK), **INCAR** (Spain, government research facility) and the universities of Darmstadt (Germany), T.U. Vienna (Austria), **Lappeenranta** (Finland), **Stuttgart** (Germany), Tsinghua (China), University of Zaragoza (Spain), Southeastern University (China), University of British Columbia (Canada) and Ohio State (USA). In addition, a very large amount of work has been done at CanMet Energy (Canada, national research centre) in conjunction with the **University of Ottawa**.

Companies which are funding research include **Endesa** (Spain, utility), Industrial Research Ltd (New Zealand, basic research), Cemex (UK, Mexico, USA and Europe, Cement manufacturer), **Foster Wheeler** (EU, OEM manufacturer), **Hunosa** (Spain, mining). Companies and Institutes which are part of the EU CaOling project have been highlighted in **bold** above.

It is fair to say that though the UK is at the leading edge of academic research in this area, along with Spain, Canada, the USA and Germany, with some of the most highly cited papers in the field<sup>225,227,198</sup>. The UK are also actively involved in the EU CaOling project, but are disadvantaged by not yet having an operational pilot plant. The focus of UK CCS research is heavily slanted towards deployment of first generation amine scrubbing at demonstration scale

The main items required (large scale CFBs) for deployment of the technology currently exist at the scale required (c.f. the lack of amine scrubbing columns of sufficient size). Foster Wheeler and Endesa are fully engaged in the EU CaOling project, demonstrating that both OEMs and utilities see Ca looping as a viable technology. Cemex is currently funding research in the UK (Imperial College) into the synergy between Ca looping and cement manufacture. However, there is little large-scale industrial interest in the technology in the UK – possibly because of the drive to commercialise MEA-based scrubbing first, and because there is little experience of CFB technology in the UK, in contrast to other countries in Europe.

There is no reason why the technology could not be deployed in the UK well before 2030, or indeed demonstrated in the UK at 30 MW scale soon after the end of the EU Caoling project, were there interest in doing so, excepting Endesa's potential conflict of interest. However, the main body of the technology has been freely developed thus far and is unencumbered from the IP point of view. This is currently changing as the technology becomes closer to market.

### ***Technical and economic characteristics***

#### ***Economics and implications for retrofitting to existing plant***

Retrofit is possible for Ca looping technology. This is not as simple a proposition as for e.g. post-combustion amine scrubbing, because it is necessary to tie in to the steam cycle or add another turbine to take advantage of the high temperature heat released in the carbonator. However, the payback for the increased complexity is a much lower overall efficiency penalty. Furthermore, the retrofit of Ca looping actually repowers the plant, allowing the production of around 30 % more electricity. Overall, the more challenging retrofit is more than made up for by these benefits. New build for standalone units firing biomass in the carbonator would reduce the overall capex by the elimination of the requirement for a separate boiler. The sections below show costs for retrofit and new build applications.

### *Application to Coal Firing / Retrofit to an Existing Plant*

Owing to the relatively low current TRL of the technology in comparison with amine scrubbing, there is a paucity of data in terms of capital cost estimation. The work of Romeo et al.<sup>228</sup> includes a very comprehensive costing. They assume 1200 € / kW for the supercritical power plant, and after appropriate assumptions about interest and costing, a total unmitigated cost of 37.9 € / MWh. The assumed capital cost for the Ca-looping system was 2936 € / kW (this is per kW of heat required for calcination, not on the basis of the fuel supplied to the power station boiler), including the cost of the CFB boiler, oxygen plant, carbonator and all associated materials. When integrated with the original boiler (and accounting for the increase in power), the total cost was 1726.6 € / kW. The overall efficiency of the system was 37.04 %. The overall capture cost was 15.7 € per tonne of CO<sub>2</sub>. New work<sup>229</sup> assumes that the power plant cost and the post-combustion capture power plant (CFB) will both be around 1100 € / kW (this is probably on the low side for the post combustion capture system), and by integration with a cement works (1900 € / kWt) gives a total cost per tonne of CO<sub>2</sub> avoided of 12.7 € / tonne of CO<sub>2</sub>. Given the low assumed capital cost of the post combustion capture equipment, it is notable that a sensitivity analysis yields a 0.8 € / tonne of CO<sub>2</sub> increase in cost for a 25 % increase in capital cost. If the more conservative capital costing assumptions of the 2008 paper<sup>228</sup> are made, the cost increases to only 14.16 € / tonne of CO<sub>2</sub>.

### *New Build / in-situ Capture*

One very detailed costing has been done<sup>230</sup> for the case of a 360 MW<sub>e</sub> pressurised fluidised bed combustor integrated with the calcium looping cycle. This work found that the cost of electricity would be around C\$ 6.471 / KWh (Canadian, 2005), with a contribution to the total cost for the capture equipment of around C\$ 1.186 / KWh. It should be noted that integration with a pressurised fluidised bed combustor would be significantly more easy than integration with a PCC power station, owing to the potential for use of the existing fluidised bed as a carbonator (i.e. for in-situ capture of CO<sub>2</sub>). The work of Mackenzie et al.<sup>230</sup> yields a cost per tonne of CO<sub>2</sub> avoided of \$23.7 (Canadian, 2005, current exchange rate 1 CAD = 0.71 €). The potential for in-situ capture of CO<sub>2</sub> from a biomass plant is examined in the work of Alonso et al.<sup>231</sup>. They compared a number of different technologies for CO<sub>2</sub> capture or avoidance. A cost of ~18 € / tonne of CO<sub>2</sub> is obtained for the biomass + Ca looping case, as opposed to 32 €/tCO<sub>2</sub> for the oxyfuel + coal combustion case, and 25 €/tCO<sub>2</sub> for the biomass + oxy-fuel plant. The capital costs for each plant were assumed to be 1,400 €/kW<sub>e</sub> for the reference coal CFB plant, 2,500 €/kW<sub>e</sub> for the coal oxy-fuel CCS plant, 1,400 €/kW<sub>e</sub> for the biomass CFB, 2,500 € / kW<sub>e</sub> for the biomass oxy-fuel CCS plant and 1,944 €/kW<sub>e</sub> for the biomass Ca-looping plant (a weighted average of the reference CFB plant and the oxy-fuel CFB).

However, because of the repowering inherent when Ca looping is used (the new power plant generates more electricity than before the retrofit), simply comparing the cost of the capture plant with the cost of an amine scrubbing capture plant is not reasonable. In order to make a fair cost comparison, the figures from *Romeo et al.* (2008) have been used<sup>228</sup>, with the capital costs for the PC combustor up-scaled to give the same total electricity output as the combined PC combustor plus Ca looping retrofit. The difference in capital costs between the two systems has then been calculated and converted to 2011 prices. This yields a 371 £<sub>2011</sub>/kW<sub>e</sub> incremental capex, and 21.6 £<sub>2011</sub>/ kW<sub>e</sub> / yr incremental opex, when taking into the additional power generated. It should be noted that the capex actually required to build a new plant with capture is 2,360 £<sub>2011</sub>/ kW<sub>e</sub> if no account is made of the increased electricity output.



It is clear that the capital costs of Ca looping are relatively low in comparison with those for other technologies. In comparison with e.g. amine scrubbing, it can be reasonably argued that there are few scale-up issues for this technology – whereas amine scrubbing towers 20 m in diameter have not yet been built.

**CO<sub>2</sub> capture rate**

Depending upon the conditions of operation, up to 97% of the CO<sub>2</sub> in the plant can be captured. In practice, a target of 90% might be more economic. Figure 2.20 shows the results, in terms of capture rate, for three different pilot plants<sup>232</sup>. The plants at IFK and Canmet reliably operated with 85% capture, whereas that at CSIC was set at 80%. The difficulty with small scale operation is to ensure a sufficiently high residence time for the gas in the carbonator that it is fully cleaned of CO<sub>2</sub> in the riser. Thus, larger plants with bigger risers should capture more CO<sub>2</sub>. In other tests, all of the plants in an equivalent chart to Figure 2.20 have demonstrated above 90% capture.

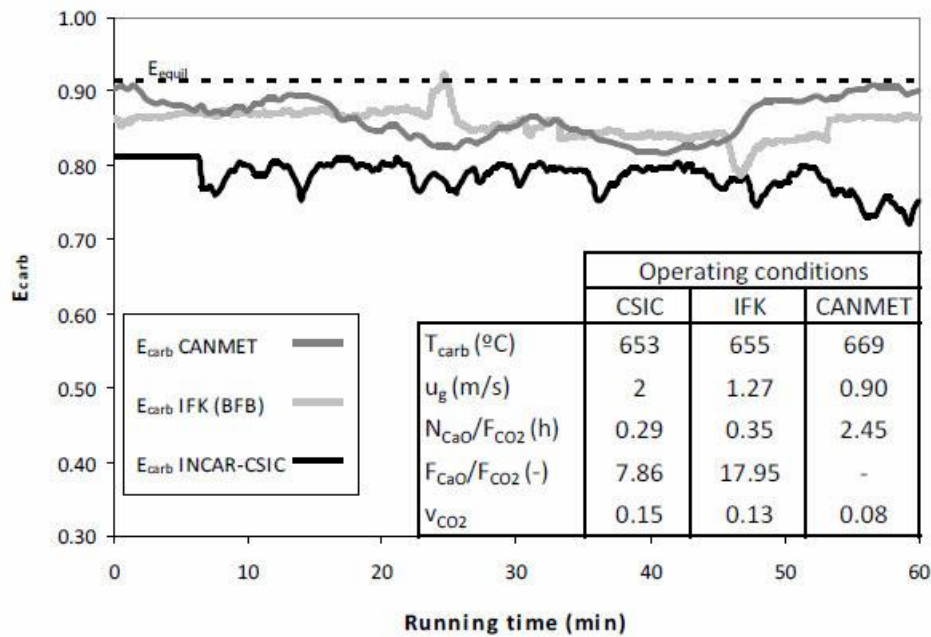

Figure 2.20: CO<sub>2</sub> capture rate of different pilot plants over time

**Flexibility and ability to load follow**

There are no anticipated problems with load following. At low plant loads it might be necessary to add supplementary air to ensure that the fluidised bed circulates properly. There will be some ability to operate at lower flowrates than the design capability without this option. The reduction in CO<sub>2</sub> for stripping will also reduce the amount of fuel required in the calciner. This is an area for further investigation in the large-scale pilot plants. One interesting possibility would be to continue to calcine material in the loop during times when low power is being produced, essentially storing chemical energy which can be released during peak times, and allowing a boost to power production.

### ***Plant efficiency with / without capture***

Based on the analysis of data from nine different sources<sup>233,234,235,236,237,228,229,230,231</sup>, the plant efficiency with capture for a retrofit is essentially limited by the efficiency of the plant providing the source of CO<sub>2</sub>. For a new build plant with direct *in-situ* capture of CO<sub>2</sub>, the plant efficiency would be limited by the availability of CFB boilers. As discussed above, Poludniowy Koncern Energetyczny (PKE) operates a 460 MW<sub>e</sub> supercritical boiler system in Poland<sup>202</sup>. There are also several different estimates for the parasitic load – these range between 6 and 8 % for the case where heat integration has been considered, including compression load. It is also important to note that Ca looping can be used to repower the plant, increasing the net power exported; a significant benefit if a large proportion of other plants are being derated by the addition of amine scrubbing.

### ***Feedstocks and feasibility***

#### ***Contaminants to be avoided***

There are no issues reported with respect to feedstock combinations if calcium looping is used to capture CO<sub>2</sub> in a post-combustion setting. For direct firing in the carbonator, care would be needed if the purge were to be used in cement manufacture to avoid elements which are known to cause issues with cement setting<sup>222</sup>, such as As, Be, Cr, Ni, V, Sr and Zn. These would not be a problem for the use of woody biomass, but could be a problem if RDF were to be used.

CaO will react with sulphur (SO<sub>2</sub>), blocking pores and increasing the rate of sorbent degradation to the point where the sorbent no longer captures CO<sub>2</sub><sup>198</sup>. However, most biomass does not contain high levels of sulphur, so this is less of an issue for biomass CCS. There are two potential solutions to this problem in the case of co-firing of coal, or where the biomass-enhanced CCS system is used to capture CO<sub>2</sub> from a plant burning coal. Firstly, if the spent sorbent is to be used in the cement industry, the purge rate can be increased and the system can be used for co-capture of sulphur and CO<sub>2</sub>, doing away with the requirement for a FGD. Secondly, the properties of the spent sorbent (changes in pore structure from small to large pores) actually improve the properties of the sorbent for SO<sub>2</sub> capture<sup>238</sup>, particularly if the sorbent is hydrated prior to use. This means that the purged limestone could be used in a small unit prior to the main carbonator, on a “once through” basis, to remove the majority of the SO<sub>2</sub> prior to the gas passing into the main looping system.

Direct firing of biomass in the carbonator has been conducted without causing serious problems in the INCAR 30 kW pilot plant<sup>239</sup>. However, it is possible that some elements present in biomass (K, Na, Cl) might give problems if fired in the calciner. This is an area requiring further study, but at present the only fuel known to have given significant problems in the calciner was petcoke, owing to the high sulphur content<sup>205</sup>.

#### ***Co-firing percentages***

There potentially could be issues with firing in the calciner, which might bring the maximum biomass proportion down to around 70 %, though this needs further investigation and optimisation – although certain feedstocks may be fine for calciner firing, it may be that others could need to be fired in some ratio. In summary, up to 100 % biomass firing is feasible, after validation of appropriate feedstocks and any proportions in which they have to be mixed.

- <sup>198</sup> Blamey, J., E. J. Anthony, et al. (2010). "The calcium looping cycle for large-scale CO<sub>2</sub> capture." *PROG ENERG COMBUST* **36**(2): 260-279
- <sup>199</sup> Sanchez, A. (2011). "EU Caoling website. [www.caoling.eu](http://www.caoling.eu). Accessed 18/04/2011.
- <sup>200</sup> Dean, C. C., D. Dugwell, et al. (2011). "Investigation into potential synergy between power generation, cement manufacture and CO<sub>2</sub> abatement using the calcium looping cycle." *Energy & Environmental Science* (DOE 2011). "US DOE list of existing generating capacity <http://www.eia.doe.gov/cneaf/electricity/page/capacity/capacity.html> Accessed 27/04/11.
- <sup>202</sup> (Power Technology 2011). " <http://www.power-technology.com/projects/lagisza/> accessed 27/04/2011."
- <sup>203</sup> Wu, Z. (2006). "Developments in fluidised bed combustion technology. CCC/110, IEA Clean Coal Centre
- <sup>204</sup> Rodríguez, N., M. Alonso, et al. (2008). "Heat requirements in a calciner of CaCO<sub>3</sub> integrated in a CO<sub>2</sub> capture system using CaO." *Chemical Engineering Journal* **138**(1-3): 148-154
- <sup>205</sup> Salvador, C., D. Lu, et al. (2003). "Enhancement of CaO for CO<sub>2</sub> capture in an FBC environment." *Chemical Engineering Journal* **96**: 187 - 195
- <sup>206</sup> Charitos, A., C. Hawthorne, et al. (2010). "Parametric investigation of the calcium looping process for CO<sub>2</sub> capture in a 10 kWth dual fluidized bed." *International Journal of Greenhouse Gas Control* **4**(5): 776-784
- <sup>207</sup> Alonso, M., N. Rodríguez, et al. (2010). "Carbon dioxide capture from combustion flue gases with a calcium oxide chemical loop. Experimental results and process development." *Int J. GHG Control* **4**(2): 167-173.
- <sup>208</sup> Rodríguez, N., M. Alonso, et al. (2011). "Comparison of experimental results from three dual fluidized bed test facilities capturing CO<sub>2</sub> with CaO." *Energy Procedia* **4**: 393-401.
- <sup>209</sup> Epple, B. (2011). "<http://www.est.tu-darmstadt.de/index.php/en/co2-versuchsfeld> accessed 18/04/2011.
- <sup>210</sup> Sanchez, A. (2011). "CaOling Project - An Exercise in Ca Looping."
- <sup>211</sup> Sánchez-Biezma, A., J. C. Ballesteros, et al. (2011). "Postcombustion CO<sub>2</sub> capture with CaO. Status of the technology and next steps towards large scale demonstration." *Energy Procedia* **4**: 852-859
- <sup>212</sup> González, B., M. Alonso, et al. (2010). "Sorbent attrition in a carbonation/calcination pilot plant for capturing CO<sub>2</sub> from flue gases." *Fuel* **89**(10): 2918-2924.
- <sup>213</sup> Wu, Y., J. Blamey, et al. (2010). "Morphological Changes of Limestone Sorbent Particles during Carbonation/Calcination Looping Cycles in a Thermogravimetric Analyzer (TGA) and Reactivation with Steam." *Energy & Fuels* **24**(4): 2768-2776
- <sup>214</sup> Abanades, J. C. and D. Alvares (2003). "Conversion limits in the Reaction of CO<sub>2</sub> with Lime." *Energy Fuels* **17**: 308 - 315
- <sup>215</sup> Grasa, G. S., J. C. Abanades, et al. (2008). "Reactivity of highly cycled particles of CaO in a carbonation/calcination loop." *Chemical Engineering Journal* **137**(3): 561-567
- <sup>216</sup> Li, Y., C.-S. Zhao, et al. (2008). "CO<sub>2</sub> capture using CaO modified with ethanol/water solution during cyclic calcination/carbonation." *Chemical Engineering and Technology* **31** 237-244.
- <sup>217</sup> Manovic, V. and E. J. Anthony (2008). "Thermal Activation of CaO-Based Sorbent and Self-Reactivation during CO<sub>2</sub> Capture Looping Cycles." *Environmental Science & Technology* **42**(11): 4170-4174.
- <sup>218</sup> González, B., J. Blamey, et al. (2011). "Calcium looping for CO<sub>2</sub> capture: sorbent enhancement through doping." *Energy Procedia* **4**: 402-409.
- <sup>219</sup> Li, Y.-j., C.-s. Zhao, et al. (2008). "Cyclic calcination/carbonation looping of dolomite modified with acetic acid for CO<sub>2</sub> capture." *Fuel Processing Technology, in press.*
- <sup>220</sup> Li, Y., C. Zhao, et al. (2009). "Modified CaO-based sorbent looping cycle for CO<sub>2</sub> mitigation." *FUEL* **88**(4): 697-704
- <sup>221</sup> Li, Y., C. Zhao, et al. (2011). "CO<sub>2</sub> capture efficiency and energy requirement analysis of power plant using modified calcium-based sorbent looping cycle." *Energy* **36**(3): 1590-1598
- <sup>222</sup> Dean, C. C., J. Blamey, et al. "The calcium looping cycle for CO<sub>2</sub> capture from power generation, cement manufacture and hydrogen production." *Chemical Engineering Research and Design In Press, Corrected Proof*
- <sup>223</sup> Abanades, J. C., M. Alonso, et al. "Experimental validation of in situ CO<sub>2</sub> capture with CaO during the low temperature combustion of biomass in a fluidized bed reactor." *International Journal of Greenhouse Gas Control In Press, Corrected Proof*
- <sup>224</sup> Aresta, M., Ed. (2003). *Carbon Dioxide Recovery and Utilisation*, Kluwer Academic, The Netherlands. p 344.
- <sup>225</sup> Fennell, P. S., J. F. Davidson, et al. (2007). "Regeneration of sintered limestone sorbents for the sequestration of CO<sub>2</sub> from combustion and other systems." *Journal of the Energy Institute* **80**(2): 116-119
- <sup>226</sup> Manovic, V. and E. J. Anthony (2007). "Steam Reactivation of Spent CaO Sorbent for Multiple CO<sub>2</sub> capture cycles." *Environmental Science and Technology*(41): 1420 - 1425.
- <sup>227</sup> Fennell, P. S., R. Pacciani, et al. (2007). "The Effects of Repeated Cycles of Calcination and Carbonation on a Variety of Different Limestones, as Measured in a Hot Fluidized Bed of Sand." *Energy and Fuels* **21**(4): 2072-2081
- <sup>228</sup> Romeo, L. M., J. C. Abanades, et al. (2008). "Oxyfuel carbonation/calcination cycle for low cost CO<sub>2</sub> capture in existing power plants." *Energy Conversion and Management* **49**(10): 2809-2814.
- <sup>229</sup> Romeo, L. M., D. Catalina, et al. (2011). "Reduction of greenhouse gas emissions by integration of Cement Plants, Power Plants and CO<sub>2</sub> Capture Systems." *Greenhouse Gases Science and Technology* **1**(1): 72-82
- <sup>230</sup> MacKenzie, A., D. L. Granatstein, et al. (2007). "Economics of CO<sub>2</sub> Capture Using the Calcium Cycle with a Pressurized Fluidized Bed Combustor." *Energy & Fuels* **21**: 920-926

- 
- <sup>231</sup> Alonso, M., N. Rodriguez, et al. (2011). "Capture of CO<sub>2</sub> during low temperature biomass combustion in a fluidized bed using CaO. Process description, experimental results and economics." Industrial & engineering chemistry research (accepted)
- <sup>232</sup> Sanchez, A. (May 2011). CaOling project - An Exercise in Carbonate Looping. CCS - Research and Development to Implementation, London, UK.
- <sup>233</sup> Ströhle, J., A. Galloy, et al. (2009). "Feasibility study on the carbonate looping process for post-combustion CO<sub>2</sub> capture from coal-fired power plants." Energy Procedia **1**(1): 1313-1320
- <sup>234</sup> Ströhle, J., A. Lasheras, et al. (2009). "Simulation of the Carbonate Looping Process for Post-Combustion CO<sub>2</sub> Capture from a Coal-Fired Power Plant." Chemical Engineering & Technology **32**(3): 435-442.
- <sup>235</sup> Ströhle, J., M. Orth, et al. (2008). "SIMULATION OF THE CARBONATE LOOPING PROCESS FOR CO<sub>2</sub> CAPTURE WITH INTERCONNECTED FLUIDIZED BED REACTORS." Proc. 9th Int. Conf. on Circulating Fluidized Beds, Hamburg, 2008
- <sup>236</sup> Abanades Garcia, J. C., E. Anthony, et al. (2005). "Fluidized bed Combustion Systems Integrating CO<sub>2</sub> Capture with CaO." Environmental Science and Technology **39**: 2861 - 2866
- <sup>237</sup> Romano, M. (2009). "Coal-fired power plant with calcium oxide carbonation for postcombustion CO<sub>2</sub> capture." Energy Procedia **1**(1): 1099-1106
- <sup>238</sup> Manovic, V. and E. J. Anthony (2007). "SO<sub>2</sub> retention by reactivated CaO-based sorbent from multiple CO<sub>2</sub> capture cycles." Environmental science & technology **41**(12): 4435-4440
- <sup>239</sup> Alonso, M., N. Rodriguez, et al. (2011). "Capture of CO<sub>2</sub> during low temperature biomass combustion in a fluidized bed using CaO. Process description, experimental results and economics." Energy Procedia **4**: 795-802.

### 2.3.7 Oxy-combustion: Oxy-fuel boiler with cryogenic O<sub>2</sub> separation from air

Oxy-combustion<sup>240,241,242</sup> involves the combustion of a fossil fuel in a mixture of oxygen and recycled flue gas, rather than air, to produce a flue gas which comprises mainly CO<sub>2</sub> and water, rather than nitrogen and CO<sub>2</sub>. The CO<sub>2</sub> concentration in the flue gas from an oxy-combustion firing system is, therefore, significantly higher than in the flue gas from an air firing system, and hence the CO<sub>2</sub> can be cleaned, compressed and stored with significantly less downstream processing than would be necessary with air firing.

The key elements of the process are illustrated in Figure 2.21. The oxygen required for combustion in the oxy-combustion plant, is obtained from a dedicated cryogenic air separation unit. In this case, the oxygen is mixed with the combustion flue gases recycled from the FGD plant exit, to provide the combustion medium for the pulverised coal. The flue gas exhaust stream from the oxy-combustion process is chilled and compressed to separate out some of the impurities, to provide a CO<sub>2</sub> product of the required quality.

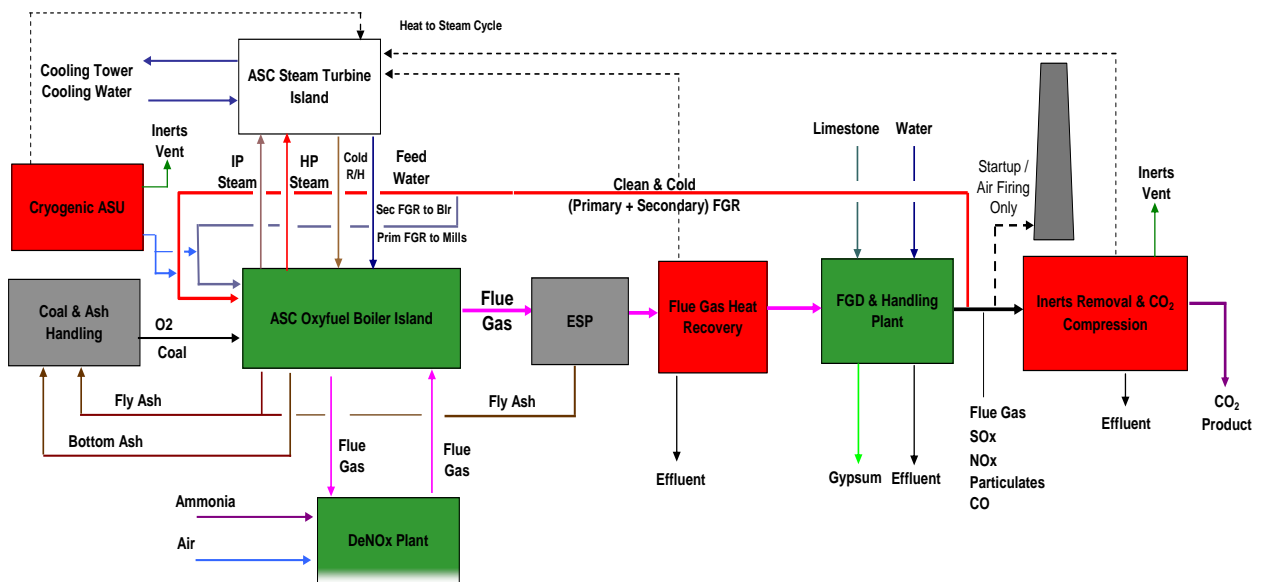

Figure 2.21: Oxy-combustion CO<sub>2</sub> capture applied to a large pulverised coal-fired power plant<sup>241</sup>

#### O<sub>2</sub> separation from air

Large-scale oxygen separation from air is generally performed by cryogenic processes based on the difference of nitrogen and oxygen boiling temperatures at a given pressure. The air is cleaned up in order to remove all impurities (dust, moisture, CO<sub>2</sub>, hydrocarbons), then compressed and cooled to condense oxygen in order to separate it from nitrogen. Cryogenic processes have been successfully applied for many years to supply oxygen for a number of industrial processes, including IGCC plants.

#### CO<sub>2</sub> treatment for Oxy-Combustion

As an illustration of some of the recent thinking on the downstream CO<sub>2</sub> purification systems associated with Oxy-fuel systems, the CO<sub>2</sub> treatment plant proposed for a coal based oxy-combustion facility that was described in a recent report from the IEA Greenhouse Gas R&D Programme<sup>243</sup>, is presented in Figure 2.22 and Figure 2.23.

The first part of the CO<sub>2</sub> treatment, illustrated in Figure 2.22, involves the cooling of the CO<sub>2</sub>-rich flue gas from the oxy-fuel combustion plant, removing some of the moisture by condensation, and the compression of the dried CO<sub>2</sub> stream to 30 bar.

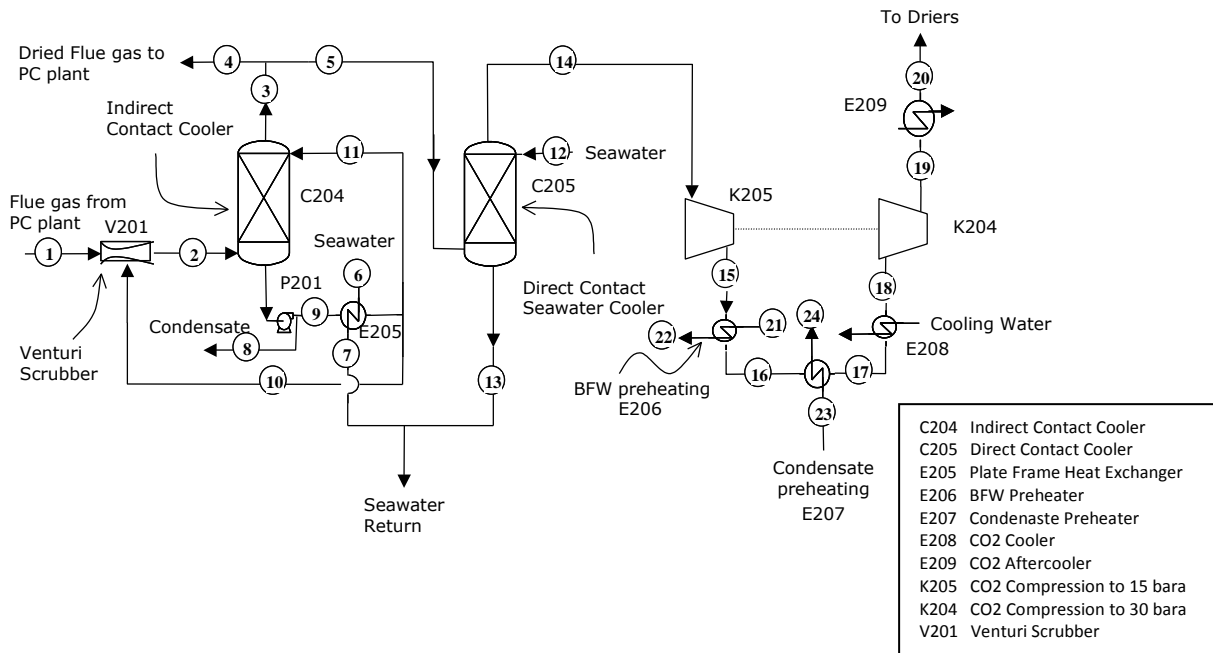

Figure 2.22: Process flow diagram for CO<sub>2</sub> cooling and compression to 30 bar

In the second phase, illustrated in Figure 2.23, the raw CO<sub>2</sub> at 30 bar is dried further, and the inert gases (principally N<sub>2</sub> and Ar) and oxygen are separated, to produce a stream with >95 mol% CO<sub>2</sub>. The CO<sub>2</sub> is then compressed further to 110 bar for pipeline transmission.

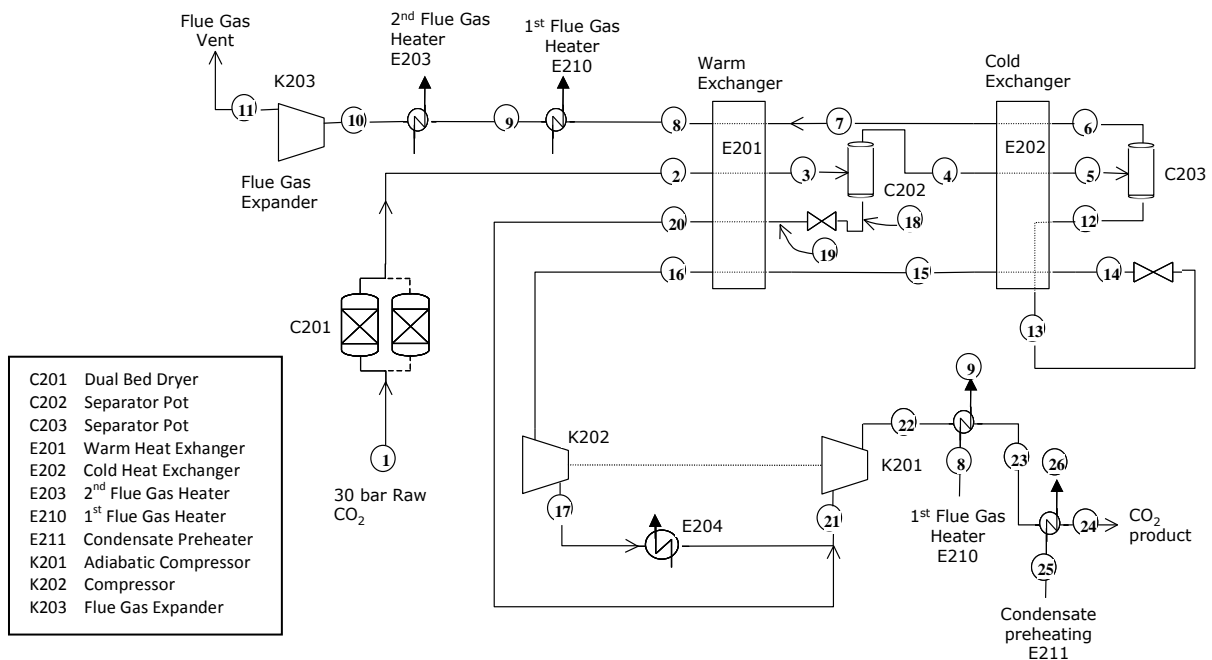

Figure 2.23: Process flow diagram for CO<sub>2</sub> and inerts removal and compression to 110 bar

The results of the study work indicated that the effects on the cost of installing a two or three stage flash process, or one with a distillation stage, were modest, but that the higher purity systems carry a small additional parasitic power penalty. The principal effect of producing higher purity CO<sub>2</sub> is a reduction in the CO<sub>2</sub> capture rate, since more CO<sub>2</sub> has to be vented with the condensable impurities. If the CO<sub>2</sub> purity is increased from 95% to 98%, for instance, there is a significant reduction, of around 2.3%, in the quantity of CO<sub>2</sub> captured, but there is little effect on the cost of electricity.

### ***Development aspects and prospects***

#### ***Key development drivers***

Oxy-fuel combustion has advantage of producing a flue gas with a high CO<sub>2</sub> concentration, making it potentially less energy intensive and more cost effective to remove CO<sub>2</sub> from the flue gas than with PCC. The advantages of this technology is that it is very similar in operation to conventional pulverised coal or CFB combustion, hence the facility would have very low emissions, and gas cleanup is relatively straightforward. The major disadvantage is the additional auxiliary power requirement of operating the Air Separation Unit (ASU) to produce the oxygen, and the CO<sub>2</sub> Purification Unit (CPU)<sup>244</sup>.

#### ***R&D activities***

A listing of some of the more interesting oxy-fuel combustion studies involving biomass is presented in Table 2.13. Many of these have focused on ignition and burnout testing of co-fired biomass, with a mixture of positive and negative results depending on the conditions used. Ongoing research topics include flame management with recycle, O<sub>2</sub> mixing, air/oxy mode switching, further burner design and aerodynamics optimisation, impurity behaviour and control, novel flue gas treatment, and CFD modelling<sup>245</sup>.

A study was carried out for Department of Energy (DOE)<sup>246</sup> to evaluate the technical feasibility of using pressurized oxy-fuel, i.e. the ThermoEnergy Integrated Power System (TIPS), to recover energy from biomass. The study involved a computer simulation of the TIPS plant. TIPS is a patented process that uses oxygen instead of air for combustion (oxy-fuel combustion) at elevated pressure. In this way, the principal product of the combustion reaction is a highly enriched CO<sub>2</sub> stream, which can be sent directly for ready for sequestration and industrial applications, such as enhanced oil recovery (EOR) and coal bed methane (CBM) recovery.

Arias et al.<sup>247</sup>, carried out an entrained flow reactor study of the ignition and burnout of blends of four different rank coals and biomass (Eucalyptus) under oxy-fuel conditions. Mixtures of CO<sub>2</sub>/O<sub>2</sub> of different concentration ratios were used, and the results were compared with those for simple combustion in air as a reference. An increase in the ignition temperature was detected in CO<sub>2</sub>/O<sub>2</sub> mixtures, when the oxygen concentration was the same as that of air. At an oxygen concentration of 30% or higher, however, there was a decrease in the ignition temperature. The blending of biomass with coal improved the ignition properties of the fuel in air.

It was also found that the burnout of the coals and biomass-coal blends in a mixture of 79% CO<sub>2</sub>-21%O<sub>2</sub> was lower than in air, but an improvement was achieved at 30 or 35% oxygen. The results of this work indicate that the % burnout of the fuel in CO<sub>2</sub>/O<sub>2</sub> mixtures are improved for those fuel blends including biomass.

Holtmeyer et.al.<sup>248,249</sup> carried out a programme of experimental work regarding biomass co-firing under oxy-combustion conditions. The experiments were performed in a 35 kW, horizontally-fired combustion facility, utilizing pulverized sub-bituminous coal and various biomass materials, including sawdust. The biomass particle size was varied by sieving. The moisture content of the biomass was also varied. The experimental results showed that in flames with high percentages of biomass co-firing and decreased secondary swirl, lift-off of the flame and increased NO emissions were observed at reduced loads. When a constant thermal input was maintained and the co-firing percentage was varied up to 50% biomass, a relatively constant NO emission was measured. The effect of biomass co-firing on flame stability, and NO<sub>x</sub> emissions, was found to be fairly complicated and dependent on a number of factors, including fuel particle size and composition, nitrogen and moisture content, feeding configuration, and burner hydrodynamics, including flow field and particle interactions.

**Table 2.13: Oxyfuel combustion studies with co-firing of biomass with coal (or MSW)**

Reference	Unit Description	Coal/Biomass	Aim of work
US Department of Energy <sup>246</sup>		Biomass	Computer simulation of the ThermoEnergy Integrated Power System plant and corrosion testing.
Vattenfall <sup>250</sup>		Lignite, Bituminous, (Biomass?)	Investigating oxy-fuel combustion in Schwarze Pumpe pilot plant
Valero <sup>251</sup> , (CIRCE)	Bubbling Fluidized Bed Combustor	Coal, wood pellets, olive residues	Technical feasibility of oxy-fuel combustion of blends of coal and biomass.
Arias et al. (2008) <sup>247</sup>	Entrained-Flow Reactor	2 Bituminous, Anthracite, Semi-anthracite, biomass	Ignition and burnout of coal/biomass blends
Fryda et al. (2009) <sup>252</sup> (2010) <sup>253</sup>	Lab-scale combustion simulator	Coal, 2 biomasses	Coal/biomass blends, effect of different burner zone residence times on burnout, emissions, and fouling
Brem et al. (2009) <sup>254</sup>		Coal, torrefied biomass	Understanding of torrefied biomass combustion at high co-firing coal ratios under oxy-fuel conditions, with respect to emissions, fuel ignition, burnout and ash quality
Holtmeyer et al. (2010) <sup>248,249</sup>	Horizontally-fired combustion facility	Subbituminous coal and various biomass	Experimental work about biomass co-firing under oxy-combustion conditions
Haykiri-Acma et al. (2010) <sup>255</sup>		sunflower seed shell and hazelnut shell/ Soma-Denis lignite	Effects of co-combustion on the thermal reactivity and the burnout
Syed et al. (2010) <sup>256</sup>		Coal, biomass	Fireside corrosion of operating superheaters at higher metal temperatures in power systems using coal/biomass fuels
Tang et al. (2011) <sup>257</sup>		Microalgae and municipal solid waste	Thermogravimetric analysis of combustion under N <sub>2</sub> /O <sub>2</sub> and CO <sub>2</sub> /O <sub>2</sub> atmospheres
Kuivalainen et al. (2010) <sup>258</sup>	0.8 MW <sub>e</sub> -scale oxy-combustion CFB pilot plant	Coal, biomass	Fuels and sorbent characterization



Condensed rotational separation (CRS) is an alternative process for CO<sub>2</sub> treatment being investigated by Eindhoven University (Netherlands)<sup>259</sup>. CRS is the mechanical separation of a partially condensed gas mixture into a vapour and a liquid phase by means of compression, rapid cooling to around -55°C, condensation and centrifugal separation of CO<sub>2</sub> droplets. However, in order to achieve CO<sub>2</sub> capture rates of ~90% at sufficiently high CO<sub>2</sub> purity, the input gas stream needs to have a high CO<sub>2</sub> concentration. Therefore CRS is only applicable to gas streams after oxy-fuel combustion or membrane separation. However, the energy costs of CRS and subsequent liquid CO<sub>2</sub> compression are higher than the purification and gas compression technique described above, and hence there may only be viable niche applications when using partially enriched oxy-fuel combustion (smaller ASU).

### ***Key development issues***

There is a significant ongoing R&D effort on boiler tube corrosion issues because of the potential increase of the concentrations of CO<sub>2</sub>, H<sub>2</sub>O, sulphur oxides and HCl in the flue gases in contact with the high temperature boiler surfaces within the flue gas recirculation loop.

There is also a significant development effort on the use of membrane separation techniques for oxygen separation. It is claimed by a number of the companies involved in its development that the use of membrane separation technology as an alternative to conventional cryogenic separation, for oxygen production can provide significant savings in capital and operating costs, and significant reductions in the energy requirements. These technologies and their integration options are discussed in more detail in Section 2.3.8.

The key elements of the fuel feeding and firing system are very similar to those in air firing and, in general terms, the impacts of the properties of the biomass feedstock on the performance and integrity of the oxy-fuel firing system are modest.

### ***Environmental factors***

There are no major negative environmental issues of any great significance associated with the combination of biomass firing and co-firing with oxy-fuel firing.

### ***Implications of retrofitting to existing power plant***

It is considered that oxy-fuel firing can be retrofitted to existing pulverised coal and biomass combustion plants. Retrofitting a coal oxy-fuel system for biomass co-firing or conversion to 100% biomass would also be possible. However, air leak can be a significant problem for older boilers (rates as high as 8% - 16% have been reported)<sup>260</sup>. At high air leak rates, flue gas CO<sub>2</sub> concentrations and capture rates decrease, and hence the costs of CO<sub>2</sub> capture increase.

### ***Technology Readiness Level***

The oxy-combustion of fossil fuels with CO<sub>2</sub> capture is not, as yet fully commercial. A number of integrated pilot plants have been or are currently being built, and detailed plans to build commercial power plants and to convert existing thermal power plants to oxy-combustion are being developed at the present time. Cryogenic air separation technology is commercially available.

The current TRL of oxy-fuel firing technology is therefore around TRL 6, and given the high level of international activity, is judged likely to reach TRL 8 to 9 for power applications by 2020.

***Main players internationally, Pilot and demonstration activities***<sup>244</sup>

The major players involved in the development of oxy-fuel firing technology include the major international boiler makers, including Vattenfall, Alstom, Hitachi, Babcock and Wilcox, Doosan Power Systems.

Oxy-fuel firing technology has now been demonstrated at large pilot / small demonstration scale and the major emphasis of future development is on full-scale boiler demonstration projects. This subsection below contains information on a number of these current and planned international testing activities involving oxyfuel firing at larger scale. Some of these oxy-fuel projects use only coal, others involve coal and biomass.

**Jänschwalde Power Station** is located 12 km (8 miles) north-east of Cottbus in the Federal State of Brandenburg and is the largest lignite-fired power plant in Germany. It has three modules each containing four 250-MW boilers feeding two 500-MW steam turbines. Vattenfall plans to build a new 250 MW Oxyfuel boiler to replace one of the existing boilers and to have the new unit operational by 2015. The feasibility study for the plant began in 2009. It is also planned to add at least partial post-combustion capture to one of the other existing boilers. Vattenfall has received funding of over € 180 million from the European Union Energy Programme of Recovery (EEPR) and estimates that the entire project will cost more than € 1.5 billion.

Vattenfall has also constructed, and operated since 2009, a 30 MW<sub>th</sub> oxy-coal pilot plant at their **Schwartze Pumpe** power station south of Cottbus, Germany. This includes an ASU, sub-critical steam generator, air quality control system equipment, flue gas coolers, and indirect-cooled (ammonia refrigeration) CO<sub>2</sub> purification system designed to purify CO<sub>2</sub> from 100% of the flue gas flow. This pilot unit has operated for several thousands of hours with about half of the time in oxy-combustion mode to supply the design information needed for the larger demonstration unit.

Endesa in Spain, has been awarded EEPR funding for a 323 MW<sub>e</sub> (gross) circulating fluidized bed oxy-coal project, at **Compostilla, Spain**. The project is scheduled for start-up in 2016. The technology development and FEED studies has been conducted over the period 2009-2012, and construction of the plant is to occur between 2012 and 2016.

Endesa has also been cooperating with CIUDEN, a Spanish government-funded research organization, in the construction and operation of a nominal 30 MW<sub>th</sub> oxy-coal circulating fluidized bed pilot plant in **El Bierzo, Spain**. This pilot plant will use liquid oxygen delivered to the site. It will conduct CO<sub>2</sub> purification unit operations on only a slip stream of the flue gas. CIUDEN has also installed a 20 MW<sub>th</sub> oxy-pulverized coal boiler at this site. Oxy-coal operations of the pulverized coal pilot plant are expected to commence in late 2010 with the fluidized bed operations following by about 12 months.

In August 2010, the U.S. Department of Energy announced that \$1 billion in Recovery Act funding would go towards the construction of the FutureGen 2.0 project in **Meredosia, Illinois** to re-power Amergen's 200 MW Unit 4 with oxy-combustion technology. The project will use a Babcock and Wilcox boiler and Air Liquide will provide the ASU and CPU. The unit will capture 90% of the CO<sub>2</sub> produced and plans to geologically sequester up to 1.2 million tonnes per year (1.3 million tons per year) of CO<sub>2</sub>. The project plans to have FEED and the NEPA process complete by 2012 and begin operation in 2016.

CS Energy has re-commissioned a 25 MWe pulverized coal power plant in **Biloela, Australia** for the purpose of conducting oxy-coal operations. The new facility will be a 30 MWe oxy-combustion plant,

and the first integrated oxy-combustion system in operation in the world. The project will capture the CO<sub>2</sub> and then truck it about 200 km (125 miles) away where it will be geologically sequestered in the Denison Trough. It is planned to sequester 60 tonnes (66 tons) per day over a three year period. It was announced on October 13, 2010 that construction had hit the halfway mark, and most of the equipment has been received on site. Commissioning is planned to begin in early 2011. The project has several partners including CS Energy, the Australian Coal Association, Xstrata Coal, Cooperating Research Centre for Coal in Sustainable Development (CCSD), IHI, Mitsui, Schlumberger, J-Power, J-Coal and the Cooperative Research Centre for Greenhouse Gas Technologies (CO<sub>2</sub>/CRC), the Australian government and the Queensland government.

In January 2010, Total began operation on Europe's first "end-to-end" carbon capture, transportation and storage at its demonstration facility in **Lacq, France**. The technology uses oxy-combustion of natural gas instead of coal, and produces a flue gas that is 90% CO<sub>2</sub>. This gas is piped 27 km (17 miles) where it is injected 4500 meters underground into a depleted natural gas reservoir. The project plans to sequester 120,000 tonnes (132,000 tons) of CO<sub>2</sub> over a two year period and then monitor the site for an additional three years.

**Babcock and Wilcox** tested a 30MW<sub>th</sub> oxy-combustion unit at their Clean Environment Development Facility (CEDF) in Alliance, Ohio in the 2007-2008 timeframe. Bituminous, sub-bituminous and lignite coals were all tested and switching between air firing and oxygen enriched flue gas was demonstrated. Environmental performance demonstrated on the unit was very promising with SO<sub>x</sub> removal approximately the same and NO<sub>x</sub> emissions were 40-70% lower than air-blown combustion, depending on the fuel. Good mixing of the oxygen into the flue gas ductwork was also demonstrated.

ENEL has proposed building a 48 MW<sub>th</sub> Pilot Plant at the **Brindisi Coal fired Power Plant** in Italy. This will be a scale-up of the 5 MW<sub>th</sub> ENEL/ITEA pressurized oxy-coal facility in Gioia del Colle, Italy that has been in operation since 2005. The pilot plant plans to begin operation in 2012.

### ***UK capabilities***

Doosan Babcock are involved in the development of oxy-fuel firing technology, principally for the large coal-fired boiler market in Europe and elsewhere. Doosan Babcock are also equipment suppliers, and have demonstrated a 40MW<sub>th</sub> OxyCoal burner in collaboration with the UK Government and other sponsors in **Renfrew, Scotland**. The burner is a full-sized utility burner suitable for installation as a retrofit or in a new unit. Work began on the unit in the summer of 2009, and the test-work was completed in 2010.

Alstom has a CCS consortium proposal in the EU's NER300 competition to build a new supercritical coal-fired boiler with oxy-fuel firing to be built on the Drax site in North Yorkshire.

### ***Technical and economic characteristics***

#### ***Equipment scales***

It is most likely that oxy-fuel technology will have application principally at the larger scales of operation. The most likely range of applications would be from about 100 MW<sub>e</sub> to 1,000 MW<sub>e</sub>. Currently, a single ASU train can produce up to around 4,000 tonnes of O<sub>2</sub> per day, with future plans to scale up to 5,000 or even 7,000 tonnes of O<sub>2</sub> per day<sup>261</sup>.

### ***Flexibility***

The integration of the boiler with a conventional ASU may have a significant impact on the power plant operational flexibility, in terms of start-up and shut down times and the boiler ramp rates and ability to follow load demand. This is because most cryogenic oxygen plants can only vary their O<sub>2</sub> output slowly, and will be integrated within the plant. A typical ASU ramping rate might be 1%/min, with 2%/min achievable with advanced control. 3%/min is possible when “designed in” as a new build plant, and higher ramping rates are possible if liquid oxygen backup is used (although expensive)<sup>261</sup>.

Future O<sub>2</sub> membrane separation technologies might have improved flexibility, although will still require heat integration due to their required operating temperatures.

### ***Efficiency with capture***

There is a significant energy penalty when operating in oxy-combustion mode, associated principally with the operation of the air separation unit. Current estimates indicate that the energy penalty associated with the oxy-fuel firing systems and the associated CO<sub>2</sub> compression plant will have the effect of reducing the overall cycle efficiency of the power plant on a LHV basis by around 8-10 %-points. However, capture and compression efficiency penalties as small as 6 %-points have been reported, with only a 5 %-point penalty expected in the future<sup>262</sup>.

The energy efficiency of the cryogenic ASU process is still being improved by major manufacturers (Air Liquide, Air Products and Praxair), and current electrical consumption is now estimated to be less than 200 kWh/tonne of oxygen depending on the application. Unlike IGCC applications, oxy-combustion doesn't need pure nitrogen, and only needs oxygen at low pressure. ASU systems optimised for oxy-fuel applications are currently at 150-160 kWh/tO<sub>2</sub>, with a 2015 target of 145 kWh/tO<sub>2</sub>, whilst power consumption is still above 200 kWh/tO<sub>2</sub> for most IGCC applications<sup>261</sup>.

There are also more advanced ASU concepts under development, such as producing high pressure, hot nitrogen to be used in a separate nitrogen turbine. Higher ASU pressures would reduce footprint, capex and energy costs (110 kWh/t could potentially be achieved), but nitrogen turbines and compressors have to be developed<sup>262</sup>.

### ***CO<sub>2</sub> capture rate, economics***

A very valuable review of the techno-economic data published between 2006 and 2010 on CO<sub>2</sub> capture from power generation was recently carried out by Finkenrath, for the IEA<sup>263</sup>. The study focuses on CO<sub>2</sub> capture from new-build coal-fired and natural gas-fired power generation plants above 300 MW<sub>e</sub> power output. Dedicated biomass-fired plants were not evaluated in this review.

The evaluation of coal-fired power generation with oxy-combustion CO<sub>2</sub> capture analysed 11 different cases, including supercritical (SCPC) and ultra-supercritical (USCPC) pulverized coal boilers. The data table has been reproduced in Table 2.14, and indicates that the installation of oxy-combustion CO<sub>2</sub> capture and compression to a new build ~550 MW<sub>e</sub> coal-fired power plant would:

- Capture on average 88% of the emitted CO<sub>2</sub> (with a range of capture rates from 87% to 89%), with CO<sub>2</sub> purities >99.9%. It is worth noting that there are 4 cases given in Table 2.14 with 100% capture rates (i.e. 0 kgCO<sub>2</sub>/MWh), but the resulting CO<sub>2</sub> purity is only 83%. This figure is supported by the results of pilot plant and engineering studies, which have indicated that CO<sub>2</sub>

capture rates of at least 85-90% will be achievable with oxy-combustion systems under commercial conditions

- Decrease the plant efficiency by 23% on average, i.e. between 7.9 and 12.2 %-points (LHV)
- Increase the overnight specific capital costs by 74% on average (with a range from 50% to 100%). This is from an average of 2,263 \$/kW<sub>e</sub> increasing to 3,959 \$/kW<sub>e</sub> (i.e. 1,437 £<sub>2011</sub>/kW<sub>e</sub> increasing to 2,513 £<sub>2011</sub>/kW<sub>e</sub>)
- Increase the LCOE by 64% on average (with a range from 45% to 90%). This is from an average of 62 \$/MWh increasing to 102 \$/MWh (i.e. 39 £<sub>2011</sub>/MWh increasing to 65 £<sub>2011</sub>/MWh)

**Table 2.14: Oxy-combustion capture from coal-fired power generation**<sup>263</sup>

Regional focus	OECD											China	Average (OECD)
Year of cost data	2005	2005	2007	2007	2007	2007	2007	2007	2009	2009	2009		
Year of publication	2007	2007	2008	2010	2010	2010	2010	2010	2009	2009	2009		
Organisation	GHG IA	MIT	NETL	NETL	NETL	NETL	NETL	NETL	GCCSI	GCCSI	NZEC		
<b>ORIGINAL DATA AS PUBLISHED (converted to USD)</b>													
Region	EU	US	US	US	US	US	US	US	US	US	CHN		
Specific fuel type	Bit coal	Bit coal	Bit coal	Sub-bit coal	Sub-bit coal	Lignite	Sub-bit coal	Lignite	Bit coal	Bit coal	Bit coal		
Power plant type	USCPC	SCPC	SCPC	SCPC	SCPC	SCPC	CFB	CFB	SCPC	USCPC	USCPC		
Net power output w/o capture (MW)	758	500	550	550	550	550	550	550	550	550	824	566	
Net power output w/ capture (MW)	532	500	550	550	550	550	549	550	550	550	673	543	
Net efficiency w/o capture, LHV (%)	44.0	40.4	41.4	40.6	40.6	39.4	40.9	40.2	41.4	46.8	43.9	41.6	
Net efficiency w/ capture, LHV (%)	35.4	32.1	30.7	32.5	29.5	31.4	31.6	30.7	30.8	34.7	35.6	31.9	
CO <sub>2</sub> emissions w/o capture (kg/MWh)	743	830	800	859	859	925	846	884	800	707	797	825	
CO <sub>2</sub> emissions w/ capture (kg/MWh)	84	104	0	98	0	103	99	105	0	0	98	59	
Capital cost w/o capture (USD/kW)	1 408	1 330	1 579	1 851	1 851	2 003	1 938	2 048	2 587	2 716	856	1 931	
Capital cost w/ capture (USD/kW)	2 205	1 900	2 660	3 093	3 086	3 163	3 491	3 821	4 121	3 985	1 266	3 153	
Relative decrease in net efficiency	20%	21%	26%	20%	27%	20%	23%	24%	26%	26%	19%	23%	
<b>RE-EVALUATED DATA (2010 USD)</b>													
Overnight cost w/o capture (USD/kW)	1 720	1 868	1 976	2 317	2 317	2 507	2 426	2 563	2 409	2 529	938	2 263	
Overnight cost w/ capture (USD/kW)	2 875	2 849	3 555	4 133	4 124	4 227	4 665	5 106	4 098	3 962	1 481	3 959	
LCOE w/o capture (USD/MWh)	69	59	61	56	56	62	59	63	70	70	51	62	
LCOE w/ capture (USD/MWh)	101	84	100	96	97	100	108	119	112	106	69	102	
Cost of CO <sub>2</sub> avoided (USD/tCO <sub>2</sub> )	49	35	49	52	47	46	66	72	52	50	27	52	
Relative increase in overnight cost	67%	53%	80%	78%	78%	69%	92%	99%	70%	57%	58%	74%	
Relative increase in LCOE	47%	43%	65%	71%	72%	62%	84%	89%	60%	51%	36%	64%	

Notes: Data cover only CO<sub>2</sub> capture and compression but not transportation and storage. Overnight costs include owner's, EPC and contingency costs, but not IDC. A 15% contingency based on EPC cost is added for unforeseen technical or regulatory difficulties for CCS cases, compared to a 5% contingency applied for non-CCS cases. IDC is included in LCOE calculations. Fuel price assumptions differ between regions. CO<sub>2</sub> purities >99.9% apart from GHG IA (96%), GCCSI (83%) and NETL case with 29.5% (LHV) efficiency (83%).

<sup>240</sup> Reports on Carbon Dioxide Capture and Storage available at <http://www.ieaghg.org/> and <http://www.iea-coal.org.uk/site/2010/home>

- <sup>241</sup> Panesar, R., Lord, M., Simpson, S., White, V., Gibbins, J., and S. Reddy (2006) "Coal-Fired Advanced Supercritical Boiler/Turbine Retrofit with CO<sub>2</sub> Capture", 8<sup>th</sup> International Conference on Greenhouse Gas Control Technologies, Trondheim, Norway, June, 2006
- <sup>242</sup> IEA Greenhouse Gas R&D Programme "CO<sub>2</sub> Capture Ready Plants, Technical Study", Report Number 2007/4, May 2007.
- <sup>243</sup> IEA Greenhouse Gas R&D Programme "Oxy combustion Process for CO<sub>2</sub> Capture from Power Plant", Report No:2005/9, July 2005
- <sup>244</sup> EPRI (2010) "Oxy-Coal Technology for Carbon Dioxide Capture: Worldwide Development Activity Update", Palo Alto, 1019673, December 2010.
- <sup>245</sup> Wall, T., Stanger, R. And S. Santos (2011) "Demonstrations of coal-fired oxy-fuel technology for carbon capture and storage and issues with commercial deployment", International Journal of Greenhouse Gas Control, 415, In press
- <sup>246</sup> US DOE (2007) "Pressurized Oxidative Recovery of Energy from Biomass", Final Technical Report, 10 June 2007, available at: [www.osti.gov/bridge/purl.cover.jsp;jsessionid=ED13AE05E52B94B2244F36A172B0ED3C?pu=915087-EPTRmW](http://www.osti.gov/bridge/purl.cover.jsp;jsessionid=ED13AE05E52B94B2244F36A172B0ED3C?pu=915087-EPTRmW)
- <sup>247</sup> Arias, B., Pevida, C., Rubiera, F., and J.J. Pis (2008) "Effect of Biomass Blending on Coal Ignition and Burnout During Oxy-Fuel Combustion", Fuel, 87, 2753-2759
- <sup>248</sup> Holtmeyer, M.L., Skeen, S.A., Kumfer, B.M., Axelbaum, R., and S. Li (2010) "Air-Fired and Oxy-Combustion of Coal and Biomass to Reduce Greenhouse Gas Emissions", Third International Symposium: Global Energy Future, St. Louis Missouri, USA, October 1-5, 2010. Links available at: <http://mageep.wustl.edu/Program2010/> and <http://mageep.wustl.edu/Program2010/Presentations/SessionI/CleanCoal/Air-Fired.pdf>
- <sup>249</sup> Holtmeyer, M.L., Skeen, S.A., Kumfer, B.M., and R. Axelbaum (2010) "Effects of Particle Size on Nitric Oxide Emissions During Coal/Biomass Combustion Under Air-Fired and Oxy-Fuel Conditions", ALChE Annual Meeting, Salt Lake City, UT, November 7-12, 2010. Links available at: <http://aiche.confex.com/aiche/2010/webprogram/Paper199170.html> and <http://aiche.confex.com/aiche/2010/webprogram/Session15865.html>
- <sup>250</sup> Vattenfall, Schwarze Pumpe (2011) "The Schwarze Pumpe pilot plant" available at: [http://www.vattenfall.com/en/ccs/schwarze-pumpe\\_73203.htm](http://www.vattenfall.com/en/ccs/schwarze-pumpe_73203.htm)
- <sup>251</sup> Valero, A., Romeo, L.M., Diez, L.I. and A. Perez (2006) "Oxy-Co-Firing: A Negative CO<sub>2</sub> Emission Process", CIRCE (Research Centre for Energy Resources and Consumptions), available at: [http://teide.cps.unizar.es:8080/pub/publicir.nsf/codigos/0381/\\$FILE/cp0381.pdf](http://teide.cps.unizar.es:8080/pub/publicir.nsf/codigos/0381/$FILE/cp0381.pdf)
- <sup>252</sup> Fryda, L., Sobrino, C., Cieplik, M., Bertrand, C., de Jong, W. and W.L. van de Kamp (2009) "Comparative Study of Ash Deposition under Air and Oxyfuel Combustion of Coal/Biomass Blends", 4th European Combustion Meeting, ECM-2009, 14-17 April, Vienna, 2009. Available at: [http://www.combustion.org.uk/ECM\\_2009/P810315.pdf](http://www.combustion.org.uk/ECM_2009/P810315.pdf)
- <sup>253</sup> Fryda, L., Sobriona, C., Cieplik, M. and W.L. van de Kamp (2010) "Study on Ash Deposition dunder Oxyfuel Combustion of Coal/Biomass Blends", Fuel, 89, 1889-1902
- <sup>254</sup> Brem, G., Geurts, B., van der Meer, T., de Goey, P., Kuerten, H., and J. van Oijen (2009), "BIOxyfuel – Torrefied Biomass Combustion under Oxyfuel Conditions in Coal Fired Power Plants", Project Number 10416, Brandbrief 2009. Available at: <http://www.stw.nl/NR/rdonlyres/941A30CB-B888-4E16-B606-206B2F9EED8A/0/Brandbrief20090714.pdf> Project details available at: <http://www.stw.nl/Projecten/T/tpc/10416.htm>
- <sup>255</sup> Haykiri-Acma, H., Turan, A.Z., Yaman, S. and S. Kucukbayrak (2010) "Controlling the Excess Heat from Oxy-Combustion of Coal by Blending with Biomass", Fuel Processing Technology, 91, 1569-1575
- <sup>256</sup> Syed, A.U., Simms, N.J., and J.E. Oakey (2011) "Fireside Corrosion of Superheaters: Effects of Air and Oxy-Firing of Caol and Biomass", Fuel, article in press
- <sup>257</sup> Tang, Y., Ma, X. And Z. Lai (2011) "Thermogravimetric Analysis of the Combustion of Microalgae and Microalgae Blended with Waste in N<sub>2</sub>/O<sub>2</sub> and CO<sub>2</sub>/O<sub>2</sub> Atmospheres", Bioresource Technology, 102, 1879-1885
- <sup>258</sup> Kuivalainen, R., Eriksson, T., Hotta, A., Sacristan, A.S.-B., Jubitero, J.M., Ballesteros, J.C., Lupion, M., Cortes, V., Anthony, B., Jia, L., McCalden, D., Tan, Y., He, I., Wu, Y., and R. Symonds (2010) "Development and Demonstration of Oxy-Fuel CFB Technology", presented at thje 35th International Technical Conference on Clean Coal&Fuel Systems, Cleawater, florida, USA, June, 6-11, 2010. Available at: [http://www.fwc.com/publications/tech\\_papers/files/TP\\_CCS\\_10\\_3.pdf](http://www.fwc.com/publications/tech_papers/files/TP_CCS_10_3.pdf)
- <sup>259</sup> Van Benthum, R.J., H.P. van kemenade, J.J.H. Brouwers and M. Golombok (2010) "CO<sub>2</sub> capture by Condensed Rotational Separation" Proc. Int. Pittsburgh Coal conference, Istanbul, October 11–14, 2010, available at: <http://www.mate.tue.nl/mate/pdfs/12195.pdf>
- <sup>260</sup> Shah, M. (2007) "Advanced Clean Coal Technologies for CO<sub>2</sub> capture", available at: [http://www.praxair.com/praxair.nsf/AllContent/3051E72FBAB659DC8525737800667F96/\\$File/Shah%20-%20Praxair%20-%20CO2%20Capture%20-%20Pittsburgh%20Coal%20Conf%202006.pdf](http://www.praxair.com/praxair.nsf/AllContent/3051E72FBAB659DC8525737800667F96/$File/Shah%20-%20Praxair%20-%20CO2%20Capture%20-%20Pittsburgh%20Coal%20Conf%202006.pdf)
- <sup>261</sup> White, V., Armstrong, P. And K. Fogash (2009) "Oxygen supply for oxyfuel CO<sub>2</sub> capture", 1<sup>st</sup> Oxyfuel combustion conference, 8-11 September 2009, Cattbus, Germany. Available at: [http://www.co2captureandstorage.info/docs/oxyfuel/OCC1/Session%204\\_B/Oxygen%20Supply%20for%20CO2%20Cap%20ture%20IEA%20GHG%20September%202009final.pdf](http://www.co2captureandstorage.info/docs/oxyfuel/OCC1/Session%204_B/Oxygen%20Supply%20for%20CO2%20Cap%20ture%20IEA%20GHG%20September%202009final.pdf)
- <sup>262</sup> Tranier, J.-P., Dubettier, R. and N. Perrin (2009) "Air Separation Unit for Oxy-Coal Combustion Systems", 1<sup>st</sup> Oxyfuel combustion conference, 8-11 September 2009, Cattbus, Germany. Available at: [http://www.co2captureandstorage.info/docs/oxyfuel/OCC1/Session%204\\_B/1st%20IEA%20GHG%20oxyfuel%20conf%20ASU%20090909\\_final.pdf](http://www.co2captureandstorage.info/docs/oxyfuel/OCC1/Session%204_B/1st%20IEA%20GHG%20oxyfuel%20conf%20ASU%20090909_final.pdf)
- <sup>263</sup> Finkenrath, M., Cost and Performance of Carbon Dioxide Capture from Power Generation Working Paper, International Energy Agency, 2011.

### 2.3.8 Oxy-combustion: Ion-exchange membrane separation of O<sub>2</sub> from air

Ion-exchange membrane (IEM), or ion transport membrane (ITM), technology utilizes non-porous ceramic membranes, fabricated from multi-component metallic oxides that have both high electronic and oxygen ion conductivity at high temperatures (greater than 700°C). There are three main process concepts using ITM technology<sup>264</sup>, distinguished by the three different driving forces (see Figure 2.24):

- **SEOSE™ Oxygen Generators:** the membranes are fabricated from oxygen ion conductors with low electron conductivity and can be used when a voltage is applied across them to separate and compress oxygen from a low-pressure source, for example air, to a high pressure product oxygen stream. However, this is a very expensive option, and likely to be for niche applications only
- **ITM Oxygen:** mixed ionic and electronic conductors are incorporated into processes which impose an oxygen partial pressure differential across the membrane at high temperature, which drives oxygen ions from the high partial pressure side to the low partial pressure side. These types of membranes have potential application in large tonnage oxygen plants and in particular applications where the co-generation of electricity is required
- **ITM Syngas:** mixed-conducting ceramic membrane materials can be used in processes in which a driving force for oxygen transport is developed by depleting the oxygen partial pressure on one side of the membrane through the chemical reaction of the input fuel (e.g. natural gas). This allows oxygen to be transported from a relatively low pressure air feed to a higher pressure reaction product stream. This category of membranes has the potential for syngas production<sup>265</sup>. ITM Syngas membranes could also be used for the larger oxygen requirements of oxy-fuel combustion, producing a CO<sub>2</sub> reaction product via the same chemical potential.

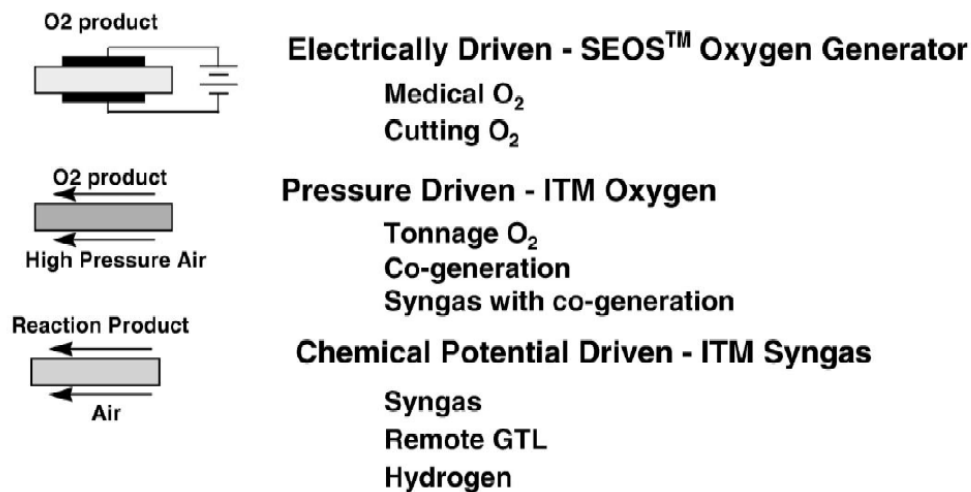

Figure 2.24: The three different ITM process concepts<sup>264</sup>

Figure 2.25 shows the ITM Syngas concept of ionic transport through an IEM membrane, where one side is fed with natural gas, and produces syngas (note that the same mechanism is applicable to coal and biomass). Heated air flows past the lower membrane surface, and only the oxygen molecules are

ionized by electrons travelling across the membrane. Driven by the oxygen partial pressure difference, oxygen ions diffuse across the barrier via oxygen vacancies in the membrane lattice. The oxygen ions then react with the input fuel to generate a syngas of carbon monoxide and hydrogen molecules, and at the same time, relinquish their electrons. The lattice structure is supposed to be 100% selective for oxygen, i.e. no other gases are transported across the barrier. An IGCC power plant would therefore plan to use the ITM Syngas membrane as its gasifier, with the rest of the downstream plant remaining the same (syngas cleaning, WGS, desulphurisation, physical absorption, combined cycle power generation with a H<sub>2</sub>-rich syngas).

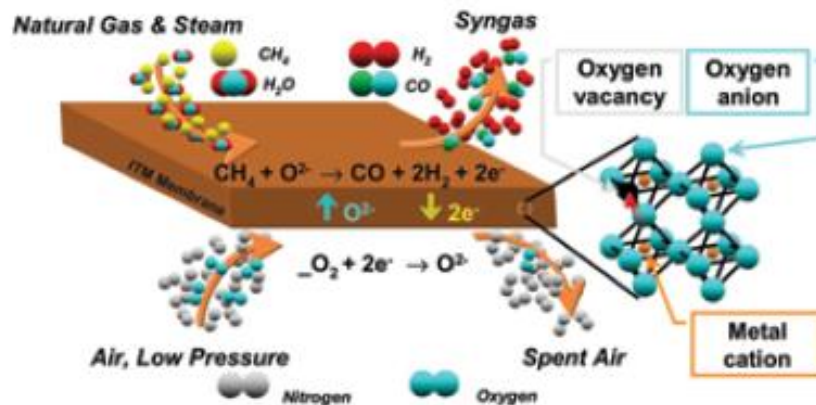

Figure 2.25: The ion transport mechanism used by ITMs<sup>266</sup>

The ITM Oxygen concept is similar, except that the partial pressure difference is no longer driven by a chemical reaction, as the membrane is not integrated inside the reactor. In operation, oxygen from a hot air stream is reduced at one surface of the membrane to oxygen ions, which diffuse through the membrane under a large pressure gradient. At the opposite surface of the membrane, the oxygen ions reform, producing very high purity molecular oxygen. This is shown below in Figure 2.26.

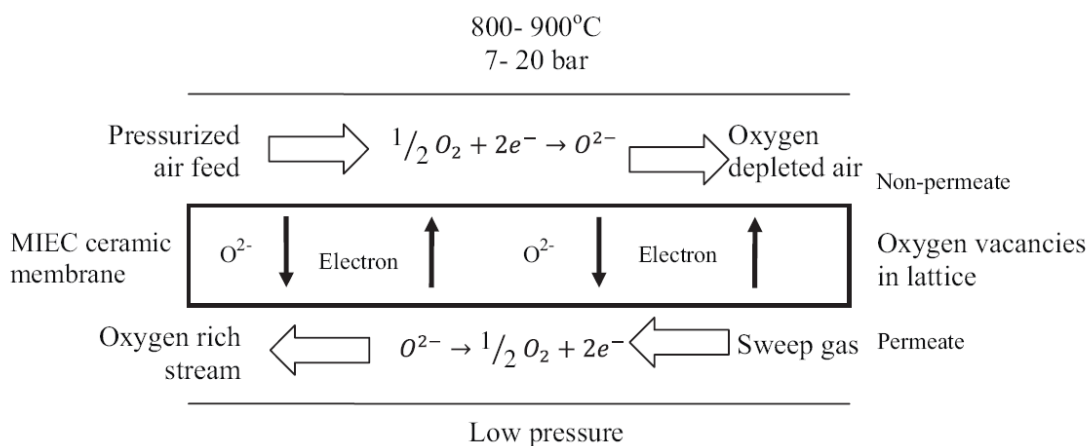
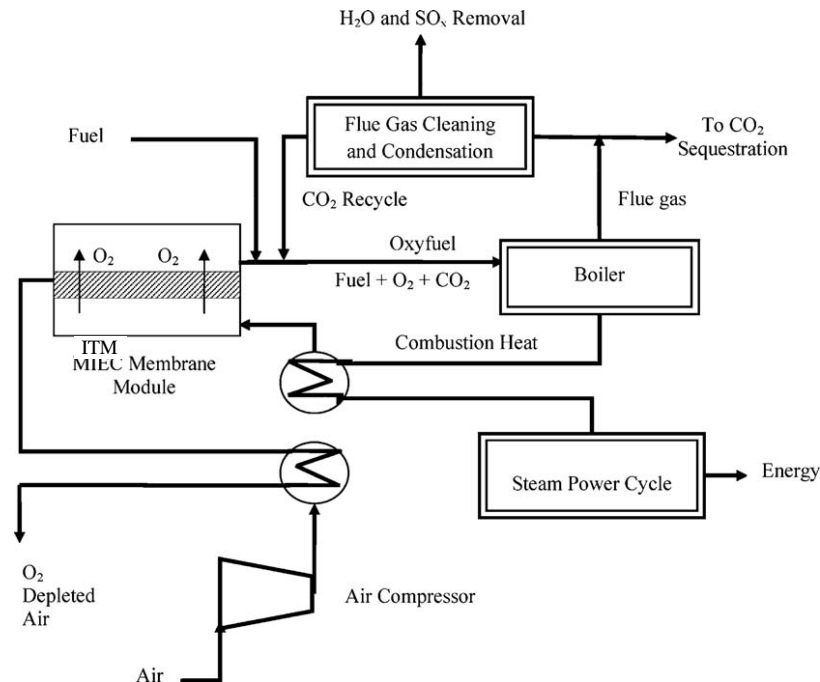

Figure 2.26: Representation of the ITM Oxygen membrane<sup>267</sup>

The heat to maintain the high temperature of the membrane can be extracted from the combination of compression of the air, hot flue gas recycle and also heat exchange from the boiler. By using recycled hot flue gas (CO<sub>2</sub>) as a slip stream to remove the O<sub>2</sub> produced, the O<sub>2</sub> partial pressure



difference across the membrane could be enhanced, thereby decreasing the compressor energy demands. The use of an ITM Oxygen membrane within an oxy-fuel plant is shown in Figure 2.27.



**Figure 2.27: Schematic of an oxy-fuel plant incorporating an O<sub>2</sub> separation membrane<sup>267</sup>**

There are also possibilities to integrate ITM Oxygen membranes within IGCC configurations, using syngas for heating and as the sweep gas, and the expansion of depleted hot air within the gas turbines<sup>268</sup>. And vice versa, ITM Syngas membranes can be used with oxy-fuel configurations, since by transporting larger quantities of oxygen, gas combustion to CO<sub>2</sub> can occur on one side of the membrane (and not just partial oxidation to syngas)<sup>269</sup>.

Regardless of the plant configuration, the oxygen flux across the membrane is given by the Nernst-Einstein equation:

$$j_{O_2} = \frac{\sigma_i RT}{4Ln^2 F^2} \ln\left(\frac{P_1}{P_2}\right)$$

Where  $j_{O_2}$  is the oxygen flux through unit area,  $\sigma_i$  is the material's ionic conductivity,  $R$  is the ideal gas constant,  $T$  is the absolute Temperature,  $L$  is the membrane thickness,  $n$  is the charge on the charge carrier, which is always 2 for oxygen ions,  $F$  is Faraday's constant,  $P_1$  is the oxygen partial pressure at the feed side, and  $P_2$  is the oxygen partial pressure at the permeate side.

Above 700°C (975 K) the flux is directly proportional to the absolute temperature and inversely proportional to the thickness of the membrane. The flux is also proportional to the natural log of the ratio of oxygen partial pressures across the membrane. This explains why the flux can be much higher when an oxygen-consuming reaction occurs on one side of the membrane (ITM Syngas) instead of just a pressure difference (ITM Oxygen).

New IEM materials are continually being created and tested. Table 2.15 lists some of these materials. Foy et al.<sup>270</sup> report some conclusions on these materials:

- BSCF appears to be the material with the highest flux among the materials investigated;

- LSGF-BSCF appears to have the highest flux among materials that are stable in a reducing environment;
- BSCF can be used to convert methane to syngas if it can be ensured that the reaction will follow the combustion and reforming mechanism;
- Supported thin film membranes allow membranes only a few micrometres thick to be created, with very high fluxes
- At the micrometer level, thickness no longer affects flux

**Table 2.15: IEM material compositions**

Name	Formula
BBCF	$\text{BaBi}_{0.4}\text{Co}_{0.2}\text{Fe}_{0.4}\text{O}_{3-d}$
BCF	$\text{BaCe}_{0.15}\text{Fe}_{0.85}\text{O}_{3-d}$
BSCF	$\text{Ba}_{0.5}\text{Sr}_{0.5}\text{Co}_{0.8}\text{Fe}_{0.2}\text{O}_{3-d}$
BTFC	$\text{BaTi}_{0.2}\text{Co}_{0.5}\text{Fe}_{0.3}\text{O}_{3-d}$
CLFC	$\text{Ca}_{0.6}\text{La}_{0.4}\text{Fe}_{0.75}\text{Co}_{0.25}\text{O}_{3-d}$
LCF	$\text{La}_{0.4}\text{Ca}_{0.6}\text{FeO}_{3-d}$
LCFC	$\text{La}_{0.6}\text{Ca}_{0.4}\text{Fe}_{0.75}\text{Co}_{0.25}\text{O}_{3-d}$
LSC	$\text{La}_{0.5}\text{Sr}_{0.5}\text{CoO}_{3-d}$
LSCF	$\text{La}_{0.6}\text{Sr}_{0.4}\text{Co}_{0.2}\text{Fe}_{0.8}\text{O}_{3-d}$
LSGF	$\text{La}_{0.15}\text{Sr}_{0.85}\text{Ga}_{0.3}\text{Fe}_{0.7}\text{O}_{3-d}$
LSGF-BSCF	$12.8\text{La}_{0.15}\text{Sr}_{0.85}\text{Ga}_{0.3}\text{Fe}_{0.7}\text{O}_{3-d}$ $\text{Ba}_{0.5}\text{Sr}_{0.5}\text{Fe}_{0.2}\text{Co}_{0.8}\text{Fe}_{0.2}\text{O}_{3-d}$

### **Development aspects and prospects**

#### **Key drivers for development**

The ITM Oxygen process is suited to integration with power generation and energy conversion processes that require oxygen as a feedstock for oxy-combustion or gasification, or in any oxygen-based application with a need for power or an export power market<sup>271</sup>. ITM technology could provide reliably supply oxygen for high-volume applications, including GTL, IGCC, oxy-fuel combustion, coal/gas/biomass-to liquids (XTL), hydrogen, Synthetic Natural Gas (SNG), carbon capture energy processes and others. The attraction of using ITM technology within an IGCC application would be to further increase plant efficiencies<sup>272</sup>.

Up to now, oxygen separation from air has been performed by cryogenic processes based on the difference of nitrogen and oxygen boiling temperatures at a given pressure. However, cryogenic processes remain energy intensive operations and research continues to investigate less energy-intensive air separation technologies in order to minimize the reduction of the host process efficiency. ITM is one such potential break-through technology, as these membranes are permeable to only oxygen, and require significantly less energy per unit of oxygen separated than cryogenic separation. This could be beneficial for both pre-combustion and oxy-combustion plants.

ITM Oxygen systems have the potential for reduced footprint, lower energy and capital costs, and better high-temperature synergies with power generation systems. ITM Syngas membranes could

combine all of these benefits within the gasification reactor, thereby further saving on equipment capital costs from not having a separate oxygen plant and gasifier.

### ***Key development issues***

It is not expected that the ITM Syngas system will resolve many of the persisting downstream IGCC issues, such as such as IGCC availability problems depending on the IGCC level of integration. IGCC and Oxy-fuel flexibility would be likely to be slightly improved using the ITM Oxygen system, as membrane technologies are inherently more flexible than cryogenic ASUs.

Being able to withstand materials expansion stresses at the high operating temperatures and chemical loadings is a key challenge – careful temperature control and reliable seals are required. Durability and contaminant tolerance of ITM Syngas with solid feedstocks are still to be proven, and the big challenges with switching to use solid feedstocks (instead of current lab-testing with natural gas) are expected to be ash behaviour and plugging. Other issues facing both ITM systems are similar to those of general membrane systems, such as capacity, stability, creep, corrosion and poisoning.

### ***Main players internationally***

Air Products is developing both ITM Oxygen and ITM Syngas concepts, having started investigations in 1988 with funding from the US DOE and in collaboration with EPRI – although current developments are focusing mainly on ITM Oxygen. Other manufacturers such as Air Liquide and Praxair are also investigating in this area, but little available information from these manufacturers was found. Main research institutes working in ITM membrane are Imperial College, Newcastle University, Twente University in Netherland, Sintef research center in Norway and European Membrane Institute in France.

### ***UK activities and capabilities***

Ian Metcalfe (Newcastle), Kang Li (Imperial) are working on ITM-Syngas concept, but only using natural gas. There are also currently no coal or biomass IGCC plants in the UK. Most component suppliers are based in the US, however, the UK's gas cleaning, turbine and chemical industry expertise should be relevant in the future, and as UK IGCC-CCS projects are developed before 2020.

### ***Equipment scales, pilots, Technology Readiness Level***

#### ***ITM Oxygen***

Current systems are only at the lab scale, although a couple of small pilot plants have emerged (such as Air Products) that are at the scale of 0.5 – 5 tonnes of O<sub>2</sub> per day. The level of development therefore corresponds to TRL 4.

The next development for Air Products is their Intermediate-Scale Test Unit at 100tpd, with plans for a unit of 2,000tpd by 2015. Technology developments are likely to continue to 2020, although the number of O<sub>2</sub> applications developed may be limited initially – oxy-fuel or IGCC CCS may not be the initial target market. The TRL of the technology is likely to reach around TRL 6 by 2020.

#### ***ITM Syngas***

The only known integrated ITM and coal combustion project is ongoing lab scale research in Utah University, in collaboration with Praxair. The current TRL is therefore 2 to 3, although biomass testing

or co-firing has not yet been conducted. Results from this research should help clarify the technical issues to overcome, and potential future pace of development.

Back in 2008, Air Products were looking to build a 1 MSCF/day pilot plant using natural gas<sup>266</sup>; however, these plans do not appear to have materialised. The future pathway for the technology, which involved reaching 25 – 125 MSCF/day demonstration scale by 2012, is no longer mentioned in Air Product's more recent literature<sup>273</sup>. However, despite this decline in industry interest, the technology should still be able to reach TRL 4 to 5 (pilot scale) by 2020 – although it remains to be seen if CCS is the primary target application (via integration in an IGCC plant), since there are numerous other syngas markets.

### ***Environmental factors***

It is expected that there will be no additional environment risks imposed by ITM systems compared to a standard IGCC plant, since the membranes are based on ceramic type materials.

### ***Implications for retrofitting to existing plant***

Conceptually, ITM Oxygen is suitable for retrofitting by simply replacing the external cryogenic O<sub>2</sub> system with an ITM Oxygen system in either an oxy-fuel or IGCC plant. However, in reality, there may be some constraints, due to the high temperature air requirements, i.e. external heat integration alongside the main boiler/gasifier, with the flue gas recycle, and/or gas turbines may be necessary.

The ITM Syngas system is considered to be impractical to integrate with existing gasifiers or coal boilers, since the membrane needs to be located inside a carefully designed fuel reactor. Using a membrane in a standard boiler or gasifier reactor would be likely to significantly reduce the residence time of particles in the reactor, leading to incomplete combustion or gasification.

### ***Technical and economic characteristics***

#### ***CO<sub>2</sub> capture rates***

In comparison with standard cryogenic oxygen separation, the O<sub>2</sub>-selectivity of both ITM Oxygen and ITM Syngas membranes are expected to be 100%, hence no syngas nitrogen or argon dilution. However, this very high selectivity is offset by the likely reduction in syngas pressure due to the membrane, which means downstream physical absorption becomes less efficient at capturing the CO<sub>2</sub>. Therefore, capture rates of ~90% are thought to be likely for an ITM Syngas-IGCC-CCS combined system.

#### ***Economics and efficiencies***

The economics and energy penalty of providing oxygen impacts the development of both oxy-fuel and IGCC processes. Although oxy-fuel combustion requires 3 to 4 times the volumes of oxygen than an IGCC plant with the same MW<sub>e</sub> output (since gasification is a limited oxygen reaction), unlike IGCC, oxy-fuel combustion does not need high pressure oxygen, nor does it need high purity nitrogen for gas turbine operation. These factors generally balance to mean that the ASU represents approximately 15% of an IGCC or oxy-fuel plant's capex, and requires a large fraction of the plant internal energy consumption – up to 10 or 15 % points from the plant's gross efficiency<sup>266</sup>. ITM Oxygen can therefore offer multiple benefits<sup>266</sup>:

- For IGCC applications: a 35% reduction in unit capital requirements over cryogenic O<sub>2</sub> ASUs, and a 35 – 40% reduction in parasitic power consumption (depending on product pressure)
- For oxy-fuel applications: a 45 – 50% reduction in unit capital requirements over cryogenic O<sub>2</sub> ASUs, and a 65 – 70% reduction in parasitic power consumption<sup>266</sup>
- ITM membranes can be integrated with other high-temperature processes to produce electrical power and/or steam from depleted air. There are also substantial reductions in cooling water consumption, and the compact, modular design has significantly smaller footprint than a cryogenic ASU plant

Membrane separation of oxygen from air is therefore expected to realise a gain of **two to three %-points** in IGCC plant efficiency, or a gain of **five to seven %-points** in Oxy-fuel plant efficiency, over current cryogenic ASU technologies. This advantage could be transformed to economic advantages if membrane cost decreases. Current membranes costs are still high and uncertain, and should decrease in the future if the market grows and matures. However, it is worth noting that the performance of cryogenic ASUs will continue to improve, hence these %-points benefits over cryogenic technologies could shrink in the future.

Due to the power consumption by a cryogenic ASU, ITM Syngas has the potential to achieve approximately a **five %-points** gain in overall plant efficiency. This equates to a 60-80% reduction in the capture efficiency penalty suffered by an IGCC plant: instead of ~8%-points loss, there would only be a 2 to 3%-points loss. Therefore, the combined efficiency of an ITM Syngas-IGCC plant with capture could be 41% currently, rising to 53% in the future with optimised gas turbines.

Given that ASUs compose around 15% of the capital cost of a coal IGCC plant without capture, by eliminating this component, up to a 11% reduction in total plant capital costs with capture could also be possible (depending on the cost of the combined gasifier/ITM Syngas membrane reactor).

### ***Feedstocks and feasibility***

#### *ITM Oxygen*

When separating oxygen from air, the membrane only comes into contact with air, hence dust plugging needs to be avoided. Biomass is not introduced into the system until downstream gasification or combustion using the O<sub>2</sub> separated by the membrane. Therefore, in this ITM Oxygen concept, suitable biomass feedstocks and specifications are only determined by the power conversion unit, and not the oxygen separation technology.

#### *ITM Syngas*

There is no experience with the use of biomass, hence there is little data available on the potential contaminants introduced by using biomass instead of natural gas. The main expected difficulties, as for coal, are ash fusion and plugging which should be avoided on membrane surface – this is particularly important for biomass, due to its lower range of ash fusion temperatures.

Sulphur compounds such as H<sub>2</sub>S and COS would also have impact on membrane performance, due to contamination, although since biomass generally has much lower sulphur than coal, this is less likely to occur than with only coal.

- 
- <sup>264</sup> Dyer P.N., Richards R.E., Russek S.L. and Taylor D.M. (2000) "Ion transport membrane technology for oxygen separation and syngas production" *Solid State Ionics* 134, pp. 21-33
- <sup>265</sup> Carolan M.F., Chen C.M. and Rynders S.W., ITM Syngas and ITM H2: Engineering Development of Ceramic Membrane Reactor Systems for Converting Natural Gas to Hydrogen and Synthesis Gas for Liquid Transportation Fuels, Proceedings of the 2002 U.S. DOE Hydrogen Program Review, NREL/CP-610-32405, 2002.
- <sup>266</sup> Air Products (2008) "Air Separation Technology— Ion Transport Membrane (ITM)", available at:  
[http://www.airproducts.com/~media/Downloads/Article/Literature\\_Cryogenic-Air-Separation-ITM-28007017GLB.ashx](http://www.airproducts.com/~media/Downloads/Article/Literature_Cryogenic-Air-Separation-ITM-28007017GLB.ashx)
- <sup>267</sup> Hashim, S.S., Mohamed, A.R. and S. Bhatia (2011) "Oxygen separation from air using ceramic-based membrane technology for sustainable fuel production and power generation" *Renewable and Sustainable Energy Reviews* 15, p. 1284-1293
- <sup>268</sup> Stein, V., Armstrong, P., Foster, T. And D. Bennett (2009) "ITM Oxygen: Taking the Next Step", presentation at Gasification Technologies 2009, Colorado Springs, 7 October 2009, available at:  
<http://www.netl.doe.gov/technologies/coalpower/gasification/projects/gas-sep/40343/40STEIN1.pdf>
- <sup>269</sup> Shah, M. (2007) "Oxy-fuel Combustion using OTM for CO2 capture from coal power plants", available at:  
<http://www.co2captureandstorage.info/docs/oxyfuel/MTG2Presentations/Session%2003/15%20-%20M.%20Shah%20%28Praxair%29.pdf>
- <sup>270</sup> Foy K. and Mc Govern J., Comparison of Ion Transport membrane, Fourth Annual Conference on Carbon Capture and Sequestration DOE/NETL, May 2-5, 2005
- <sup>271</sup> Smith A.R. and Klozek J., A review of air separation technologies and their integration with energy conversion processes, *Fuel Processing Technology*, vol. 70, 2001
- <sup>272</sup> Tonziello, J and M. Vellini (2011) "Oxygen production technologies for IGCC plants with CO2 capture" *Energy Procedia*, vol 4, pp. 637-644
- <sup>273</sup> Air Products (2010) "Air Separation Technology— Ion Transport Membrane (ITM)", available at:  
[http://www.airproducts.com/company/technology-partnerships/~media/Files/PDF/industries/ITM-DEC-10\\_DS.ashx](http://www.airproducts.com/company/technology-partnerships/~media/Files/PDF/industries/ITM-DEC-10_DS.ashx)

### 2.3.9 Oxy-combustion: Chemical-looping-combustion using solid oxygen carriers

Chemical Looping Combustion (CLC) is a process first introduced by Richter and Knoche<sup>274</sup>, in which the combustion of a carbonaceous fuel such as gasified coal or natural gas is carried out via a flameless process using oxygen provided by a metal oxide (the oxygen carrier). The process, which is illustrated in Figure 2.28, can be thought of as two separate reaction processes: reduction and oxidation. In the reduction process, a hydrocarbon fuel,  $C_nH_{2m}$ , is reacted with the oxygen carrier, reducing it to a pure metal or a lower form of the oxide whilst the fuel is oxidised to  $CO_2$  and water vapour. Condensing out the water vapour results in a pure stream of  $CO_2$  ready for sequestration. Hence, the capture of  $CO_2$  is an inherent part of the process, and is achieved without incurring any thermal efficiency penalty for the plant; in contrast, for oxyfuel combustion methods, where combustion in oxygen is only achieved after the separation of oxygen from air via an air separation unit (ASU), or for amine sorbent methods, whereby an input of heat is required to regenerate the sorbent, a plant efficiency penalty of 6-11 %-points can be expected<sup>275</sup>.

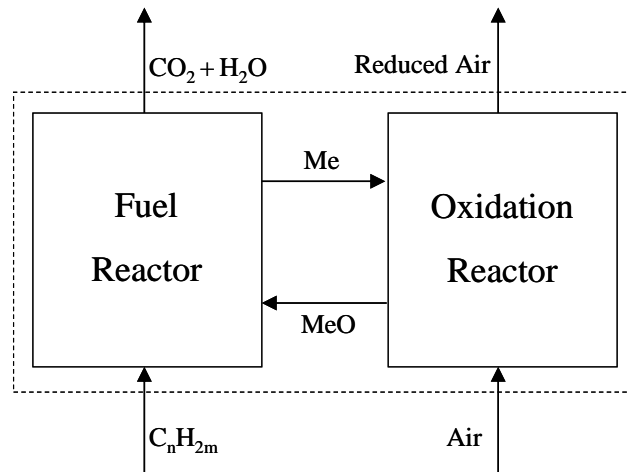
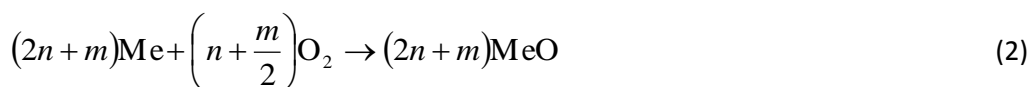
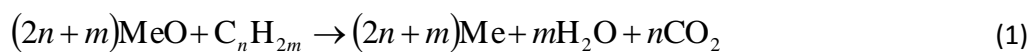
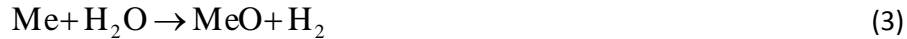

Figure 2.28: Schematic of the chemical looping combustion (CLC) process

For most metal oxides, the reduction is an endothermic, or only mildly exothermic, process. However, there are exceptions, such as the reduction of  $CuO$  to  $Cu$ . In the oxidation process, which is always exothermic, the oxygen carrier is re-oxidised to its original form, thus completing the cycle. If oxidation is carried out in air, the net heat release for the cycle is equivalent to the heat conventionally released by the combustion of the fuel in air. However, the air stream is never in direct contact with the fuel. Both the reduction and oxidation reactions can be carried out at moderate temperatures (typically 600-900 °C for reduction, 700-1000 °C for oxidation), which has the additional benefit of suppressing the formation of  $NO_x$  during oxidation. The corresponding reactions for an oxygen carrier  $MeO$  and fuel  $C_nH_{2m}$  for reduction and oxidation respectively are:



CLC is also being considered for the production of  $H_2$  for use in fuel cells<sup>276,277,278</sup>. This can be achieved if oxidation is carried out with steam instead of air, in which case the oxidation reaction takes the form:



Alternatively, a gaseous fuel may be reformed in the fuel reactor in the presence of an oxygen carrier, and subsequently converted to  $\text{H}_2$ , either through a water-gas shift reactor and pressure-swing adsorption<sup>279</sup> or the use of a sorbent to remove  $\text{CO}_2$ <sup>280</sup>. The production of  $\text{H}_2$  and generation of power need not be mutually exclusive; Chiesa *et al*<sup>281</sup> proposed a three-reactor process, shown schematically in Figure 2.29, whereby the reduced oxygen carrier is partially oxidised in steam to produce a pure stream of hydrogen (after the condensation of any remaining steam) in the steam oxidation reactor, before being returned to its most oxidised form in the air oxidation reactor.

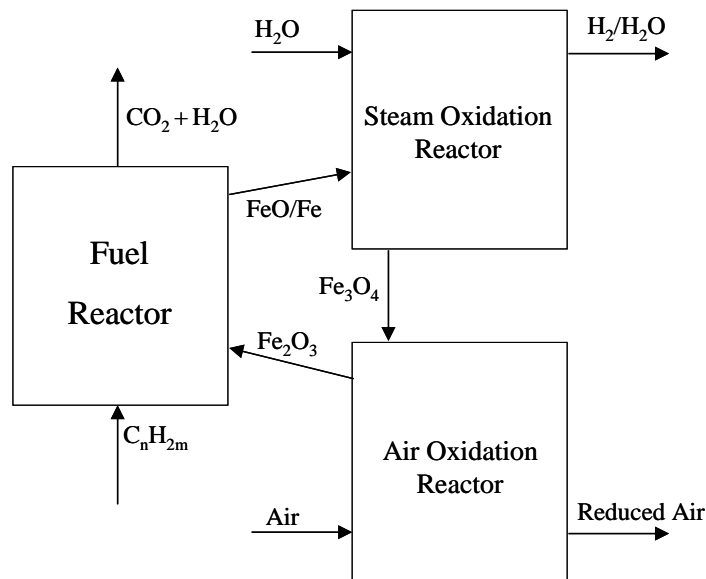

Figure 2.29: The three-reactor CLC process for simultaneous generation of heat/power

### Development aspects and prospects

#### Key drivers for development

One of the major advantages of CLC over alternative  $\text{CO}_2$  capture technologies is that the capture is achieved without any thermal efficiency penalty. Correspondingly, the thermal and exergetic efficiency of a CLC plant is very high in comparison to other options. By utilising the heat released from the air reactor to raise steam, electrical power may be derived from CLC. Additionally, if the system is pressurised, the reduced air stream may be expanded through a gas turbine for further power generation.

#### Key development issues

CLC is typically modelled as twin-interconnected fluidised bed reactors, between which the oxygen carrier is circulated<sup>282</sup>. The air reactor is typically a riser, from which the oxygen carrier particles are separated from a gas stream using a cyclone or similar device, before entering the fuel reactor where they are reduced and then returned to the air reactor. The circulation of the oxygen carrier also provides the transfer of heat from the air reactor to the fuel reactor. One of the key challenges facing CLC is its scale-up to commercial utilisation and careful optimisation of parameters such as the



reactor temperatures, the solids circulation rate, the reactor dimensions, and the air-to-fuel ratio is required to ensure a sufficiently high conversion of the fuel to CO<sub>2</sub> and H<sub>2</sub>O.

One potential technical difficulty is the required circulation rate and total solids inventory of oxygen carrier to achieve complete capture of CO<sub>2</sub>. This is highly dependent on the oxygen carrier and the fuel reactor temperature, and for oxygen carriers with low reactivity and/or oxygen capacity, a high circulation rate and solids inventory is required. Abad *et al* simulated a BFB fuel reactor achieving near-100 % conversion of methane with an inventory of 130kg/MW<sub>th</sub> for a CuO-based oxygen carrier at 1073 K, but this inventory increased by almost a factor of 10 at 973 K<sup>283</sup>. In a separate study, it was shown that an Fe<sub>2</sub>O<sub>3</sub>-based oxygen carrier required significantly higher inventories and circulation rates than either NiO- or CuO-based oxygen carriers, and may not be feasible for pressurised operation, whereby the air riser must be narrower and taller to achieve fluidisation<sup>284</sup>.

### ***Main players internationally***

There are a number of key academic players in CLC. Chalmers University in Sweden have published prolifically in the field. Other key players are Vienna University of Technology (Austria), TU Darmstadt (Germany), Ohio-State University (US), Tsinghua and Southeast universities (China) and Korea Institute of Energy Research (South Korea). In the U.K, both Cambridge University and Imperial College have considerable lab-scale interest.

Industrial activity to date has been limited but is increasing. As described below, Alstom have been a key player in recent years. Vattenfall and Air Liquide have some interest as industrial partners to pilot plant activities in Europe.

### ***Pilot and demonstration plants, and R&D activities***

Table 2.16 lists key CLC demonstration rigs and their scale. Since 2005, Chalmers University in Sweden, who have published prolifically in the field of CLC, have run with a fully operational 10 kW<sub>th</sub> plant comprising a CFB air reactor connected to a BFB fuel reactor, based on the specification of Lyngfelt *et al*<sup>282</sup>; initial work was carried out with methane<sup>285</sup> and the design has subsequently been adapted for direct solids fuels combustion<sup>286,287</sup>. The plant has subsequently achieved >1000 hours continuous operation<sup>288</sup>. In 2009, the Vienna University of Technology published its first results operating a 120 kW<sub>th</sub> plant<sup>289</sup>; this design incorporated a dual circulating fluidised bed (DCFB) configuration, shown schematically in Figure 2.30 (a). TU Darmstadt have carried out Aspen and Fortran modelling for a 1 MW<sub>th</sub> test facility, which has only very recently been erected, as part of the ÉCLAIR (Emissions-free chemical looping coal combustion process) project, funded by the EU–Research Fund for Coal and Steel<sup>290</sup>. Other key research institutions are CSIC (Spain), Ohio State University (U.S.), Southeast and Tsinghua University (China) and Korea Institute of Energy Research (South Korea). Industry participation in the development of CLC has been very limited, but is growing; Alstom, along with Air Liquide are partners of the ÉCLAIR project. Furthermore, Alstom completed construction of a 65 kW<sub>th</sub> test facility in Windsor, Connecticut in 2003. The facility has subsequently undergone successful testing with a CaSO<sub>4</sub> oxygen carrier, and a 3 MW<sub>th</sub> facility is currently under development<sup>291</sup>.

**Table 2.16: Current and forthcoming CLC demonstration plants**

Institute/Location	Scale	Year
Chalmers University, Sweden	10 kW <sub>th</sub>	2005
Alstom, Connecticut, U.S	65 kW <sub>th</sub>	2003
	3 MW <sub>th</sub>	2011
Korea Institute of Energy Research	50 kW <sub>th</sub>	2004
Vienna University of Technology	120-145 kW <sub>th</sub>	2009
TU Darmstadt, Germany	0.8-1 MW <sub>th</sub>	2011

### ***UK capabilities and activities***

Although CLC research is being carried out by Cambridge, Leeds and Imperial College, there are currently no demonstration plants in the UK, as well as very limited operating experience with bubbling or circulating fluidised bed technology. However, the degree of academic expertise in CLC within Europe (Chalmers, CSIC, TU Darmstadt) is considerable, and fluidised bed combustors / gasifiers are proven technologies elsewhere in the world, so it is perfectly conceivable that the technology could be developed and deployed quickly within the UK. Dual CFB arrangements are uncommon, however.

### ***Technology Readiness Level***

Recent years have seen advances made in both reactor design and scale. The current TRL of CLC is judged to be 4, and based on the recent progress and projected demonstration plants, may be expected to be expected to reach a TRL of 5 to 6 by 2020.

### ***Environmental factors***

Providing that the oxygen carrier comprises non-toxic materials, CLC does not pose any direct environmental risk. Gasification of biomass is likely to result in the formation of tarry compounds; however, as discussed later, the presence of the oxygen carrier during the gasification process may reduce tar formation.

### ***Technical and economic characteristics***

#### ***Equipment scales***

Based on the feasible scales of CFB combustors, CLC may be applicable for scales ranging 15-500 MW<sub>th</sub> (equivalent to 5 – 200 MW<sub>e</sub>). CLC can thus be considered suitable for small-scale power generation, and if used for H<sub>2</sub> production, could potentially be integrated directly with a H<sub>2</sub> fuel cell. As an alternative to the conventional dual fluidised bed arrangement, CLC may comprise two or more packed bed reactors in which reducing and oxidising gases are admitted sequentially into each reactor, phased in such a way that a continuous CO<sub>2</sub> stream and heat release is achieved. Such an arrangement may also be suitable for small-scale power generation, and furthermore removes the complexity of circulating a high-temperature solid stream.

#### ***Ability to load follow, flexibility***

Problems with CFB operation may result in down-time for the entire plant. Fluidised bed reactors have a fairly slow start-up time, depending on scale, and may be best to base-load operation.

However, load-following should be achievable by adjustment of solids circulation rate. In the case of combined power generation and H<sub>2</sub> production, alteration of the circulation of oxygen carrier to the steam- and air-oxidation reactors respectively shifts the plant's balance between H<sub>2</sub> and power generation.

One advantage in the development of pilot-scale CLC is its technological similarities to high-temperature solid sorbent capture e.g. Ca-looping. The 1 MW<sub>th</sub> pilot plant currently under development by TU Darmstadt may be switched quickly between operating as either a CLC or Ca-looping plant<sup>282</sup>.

### CO<sub>2</sub> capture rate

CLC is capable of achieving almost 100 % CO<sub>2</sub> capture; Fe-, Cu-, Mn- and Co- based oxygen carriers are theoretically capable of complete conversion of the fuel to CO<sub>2</sub> and H<sub>2</sub>O at temperatures of 800-1000°C, whilst Ni-based oxygen carriers enable 99 % capture<sup>292</sup>. Based on their theoretical conversion efficiency, reactivity during both oxidation and reduction, and melting points, Fe-, Cu- and Ni- based oxygen carriers are the most promising candidates for CLC, and experimental work has demonstrated that close to 100 % CO<sub>2</sub> capture is possible<sup>293,294</sup>.

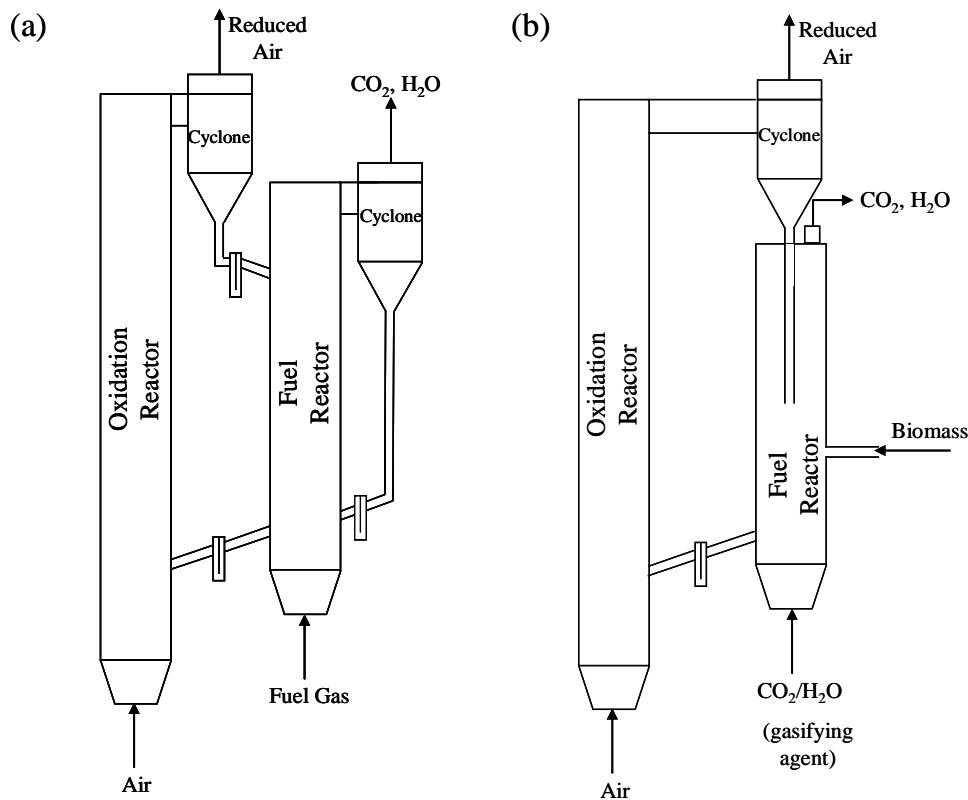

Figure 2.30: Schematic diagrams of the CLC process within (a) a dual circulating fluidised bed (DCFB) reactor and (b) suggested setup for operation with biomass (shown for a BFB fuel reactor/gasifier)

### ***Plant efficiency with capture***

A comprehensive review of thermodynamic analyses was carried out for various CLC plant arrangements<sup>295,296,297,298,299,300,301</sup>.

Exergy analyses carried out by Ishida *et al*<sup>295</sup> and Anheden *et al*<sup>296</sup> have demonstrated that power generation *via* CLC of methane compares favourably with a conventional natural gas combined-cycle power plant, and Naqvi and Bolland<sup>297</sup> estimated a net plant efficiency of 51-53 %, some 2-4 percentage points higher than a NGCC plant with 90 % CO<sub>2</sub> capture. Petrakopoulou *et al* estimated the exergetic efficiency of a CLC plant to be 5 %-points lower than a reference case combined-cycle plant without CO<sub>2</sub> capture, much of the loss being owed to the compression of captured CO<sub>2</sub>. However, with the addition of 85 % CO<sub>2</sub> capture with monoethanolamine (MEA) sorbent to the reference case, the exergetic efficiency was 6 %-points lower than for the CLC plant.

CLC with solid fuels such as coal or biomass requires the endothermic gasification of the fuel with steam and/or CO<sub>2</sub>; however, the required heat for the process may be provided by the exothermic air oxidation reaction, or by the circulation of hot oxygen carrier into the gasifier/fuel reactor, as discussed below, and so no efficiency penalty is incurred.

An ENCAP study considering a 455 MW<sub>e</sub> gross output CFB steam-generation CLC plant with CO<sub>2</sub> capture, using either bituminous coal or pet coke as a fuel, predicted efficiencies of 41.6 - 41.7 %, and an associated efficiency penalty of just 1.8-2.3 %-points<sup>302</sup>. In comparison, an equivalent oxy-fuel plant suffered a 6.4-7.2 %-point penalty, resulting in an overall efficiency of 36.7-37.1 %

Cleeton *et al*<sup>298</sup> estimated exergetic efficiencies (prior to compression of captured CO<sub>2</sub>) of close to 60 % for the CLC of coal with combined power generation and H<sub>2</sub> production. A similar model by Li *et al*<sup>299</sup> considered CLC with hybrid poplar, and estimated an optimised thermal (HHV) efficiency of 74.2 %, based on produced power and H<sub>2</sub>, with a peak thermal (HHV) efficiency based on power generation alone of 38.1 %. Hence for coal/biomass, the thermal efficiency of a CLC plant (based on power generation alone) may be thought to be ≈ 40 % i.e. equivalent to a modern coal-fired plant. This figure rises to 50 + % for a combined cycle arrangement, whereby pressurised fluidised bed combustors are used, and further power is generated by expansion of the hot, pressurised, reduced-air stream.

Since CLC offers the potential for combined power generation and H<sub>2</sub> production, *via* the process outlined in Fig. 2 or otherwise, the CO<sub>2</sub> reduction potential is high. It has been shown that H<sub>2</sub> of sufficiently high purity for PEM fuel cells is possible with CLC<sup>303,304</sup>, and so CO<sub>2</sub> offsets may be achieved in sectors such as transport, as well as power generation. Optimising the production of H<sub>2</sub> comes at the cost of electrical power output and *vice versa*; however, it has been shown that by splitting the oxygen carrier between the steam- and air oxidation reactors, or by varying the relative flows of steam and air, that a CLC plant may be operated flexibly<sup>298,299</sup>; this is a considerable asset, since the plant can be alternated between optimising electrical power output and H<sub>2</sub> production during periods of high and low energy demand respectively, and so load following should not present a significant problem.

### ***Economics***

To date, there has been limited economic analysis work carried out for CLC, due to the levels of uncertainty based on its relatively low TRL. However, an ENCAP study released in 2008 showed the economics of CLC to be highly promising<sup>302</sup>. Based on a reference case 445 MW<sub>e</sub> CFB plant without

CO<sub>2</sub> capture, using either bituminous coal or pet. coke as a fuel, the electricity costs were predicted to increase by 4-22 %, dependent on fuel for CLC, with a corresponding increase of 23-42 % for an oxy-fuel plant. The CO<sub>2</sub> avoidance costs varied from £1.0- 16.4/tonne (2004 corrected) for CLC, and were typically an order of 2-3 times higher for oxy-fuel. It should be noted that the reference CFB plant has higher associated investment costs than an equivalent PCC plant; however, the comparative costs are not presented in the published report.

Petrakopoulou *et al* carried out an exergo-economic analysis which considered the costs associated with exergy losses within each component, and compared the performance and cost (adjusted to £<sub>2011</sub>) of a 700 MW<sub>th</sub> CLC plant to that of a reference case combined-cycle plant, initially without CO<sub>2</sub> capture<sup>301</sup>. For a CLC plant of this scale, the total fixed capital investment (FCI) was estimated to be £296million, of which 13 % was attributed to the CO<sub>2</sub> compression unit, and around 35 % to the air and fuel reactors; this was in comparison to £175million for the reference plant. Correspondingly, the cost of electricity (COE) for the CLC plant was 7.4p/kWh, 24 % higher than the reference case; however, the addition of an 85 % CO<sub>2</sub> capture process *via* chemical MEA absorption resulted in a 30 % increase to the COE of the reference case. The cost of CO<sub>2</sub> capture for CLC was estimated to be £42.8/tonne of CO<sub>2</sub> captured, compared to £63.2/tCO<sub>2</sub> for the reference plant. Alstom estimated that for a 400 MW<sub>e</sub> coal-fired CLC plant, the COE would be 3.8-4.5 p/kWh (adjusted to £<sub>2011</sub>), making it favourable over other CO<sub>2</sub> capture technologies, as well as a standard PCB plant, assuming a cost on CO<sub>2</sub> of around £11.3/tonne emitted<sup>291</sup>.

Kobayashi *et al* (2009) analysed the costs of a 100 MW<sub>th</sub> Biomass Direct Chemical Looping (BDCL) process with both H<sub>2</sub> and electricity generation against corresponding IGCC plants both with and without CO<sub>2</sub> capture<sup>300</sup>. The estimated COE of 13 pence/kWh (all figures corrected from \$ in 2000 to £ in 2011), compared to 24.6 and 36.8 pence/kWh for IGCC with and without CO<sub>2</sub> capture respectively; furthermore, assuming a carbon credit of £27.2 per tonne CO<sub>2</sub> captured, it was estimated the COE would fall to 8.2 pence/kWh. The energy costs associated with preparation of biomass were taken into account; drying of wood chips from 50 % to 20 % moisture content was estimated to require 2 MJ/kg, whilst the pulverisation to a powder < 100 µm size fraction was estimated to require 2.27 MJ/kg. The latter process is particularly energy-intensive, and increases exponentially with decreasing particle size.

In the analysis by Petrakopoulou *et al*<sup>301</sup>, the cost of the oxygen carrier was assumed to be small relative to the TCI. The cost is dependent on the choice of metal oxide - at the time of writing the cost of iron ore was \$1.70 per dry tonne, in comparison to Ni which was \$26,700 per dry tonne<sup>305</sup> - but also on the durability of the oxygen carrier over repeated cycling. Hence a significant amount of work has been carried out into the choice of oxygen carrier, and can be loosely grouped into investigations into (i) high-durability synthetic oxygen carriers, and (ii) low-cost natural ores and waste industrial products<sup>306,307</sup>. Lyngfelt and Thunman<sup>285</sup> estimated that the manufacture of a synthetic oxygen carrier, ontop of material costs, was approximately 1 €/kg, based on a spray-drying process. Assuming a particle lifespan of 4000 hrs for a NiO oxygen carrier (which can be taken to be the worst-case scenario, in terms of material costs), it was estimated that the running cost for the oxygen carrier was < 1 €/tonne CO<sub>2</sub> captured (2001 estimate). Abad *et al*<sup>284</sup> assumed the same manufacturing costs and estimated that even with a more modest particle lifespan of 300 h, the cost of CO<sub>2</sub> capture was equivalent to that of MEA post-combustion capture. Thus when compared to the above CO<sub>2</sub> capture cost estimate provided by Petrakopoulou *et al*, the cost of the oxygen carrier is therefore unlikely to be a deal-breaker for the technology.

The exergetic and economic analyses carried out to date have considered CLC to be a medium-to-large scale technology, typically for the generation of many tens or a few hundred MW of electrical power. However, since CLC may be applied to the production of high-purity H<sub>2</sub> for fuel cells, efficient small scale power generation is theoretically achievable. This option would significantly reduce operating costs associated with preparation and transportation of feedstock.

### ***Feedstocks and feasibility***

Whilst much of the existing work regarding CLC has considered natural gas as a fuel, almost any carbonaceous fuel may be used, and an increasing amount of work has considered the application for solid feedstocks. In the case of a solid fuel such as coal or biomass, the fuel must first be gasified; suitable gasifying agents are H<sub>2</sub>O or CO<sub>2</sub>, but air should not be used, since N<sub>2</sub> is then subsequently entrained into the resulting captured CO<sub>2</sub> stream. The gasified feedstock produces a syngas, which typically comprises CO, H<sub>2</sub>, CO<sub>2</sub> and H<sub>2</sub>O, as well as small amounts of other species, which may then be converted by the oxygen carrier in the fuel reactor to CO<sub>2</sub> and H<sub>2</sub>O. During the initial stage of gasification, the feedstock thermally decomposes to yield volatile matter and solid char. This initial step typically occurs very quickly, and so gasification of the char usually rate-limiting, being significantly slower than either the oxidation or reduction reactions, as highlighted by Leion *et al*<sup>308</sup>. It has, however been shown for a variety of coals that introducing the solid fuel to the fuel reactor and gasifying “in-situ” i.e. in the presence of the oxygen carrier significantly enhances the rate of gasification<sup>309,310,311,312,313,314</sup>. This has been attributed to the removal of the gasification products H<sub>2</sub> and CO which are oxidised to H<sub>2</sub>O and CO<sub>2</sub> by the oxygen carrier, and would otherwise impede the gasification reaction<sup>315</sup>. Furthermore, it has been suggested that the oxygen carrier may oxidise coal char directly to CO<sub>2</sub> and H<sub>2</sub>O without the presence of a gasifying agent<sup>316,317,318</sup>; however, the general consensus is that the solid-solid rate of reaction is insufficient to negate the gasifying agent. An additional advantage of gasification in the presence of an oxygen carrier is that circulation of the oxygen carrier from the high-temperature air reactor provides the necessary heat for the endothermic gasification reaction. Therefore, whilst separate gasification, followed by combustion of the syngas in the fuel reactor is an option, it is recommended that gasification and combustion occur concurrently within a single bubbling or circulating fluidised bed reactor (shown schematically in Figure 2.30 (b)); ratings for the compatibility of different biomass conversion technologies with CLC are listed in Table 2.17. However, clever cyclone design to separate char and oxygen carrier particles is required; if char is carried into the air reactor, it will be combusted and released as uncaptured CO<sub>2</sub>. However, recovered biochar is a useful byproduct, which may be added to soils to act as a carbon sink, and to enhance fertility of the soil.

### ***Contaminants of risk, plant modifications***

The gasification of biomass presents both advantages and disadvantages to CLC. Biomass typically comprises a higher volatile content than coal, thereby enhancing the rate of gasification, and reducing the amount of char carried into the oxidation reactor(s). Furthermore, the relatively high gasification temperatures, in addition to the presence of the oxygen carrier, may assist in the decomposition of tarry compounds. However, the rapid devolatilisation of biomass at high temperatures may exceed the rate of conversion to CO<sub>2</sub> and H<sub>2</sub>O achievable by the oxygen carrier, and lower CO<sub>2</sub> capture rate<sup>319,320</sup>. Ash from biomass combustion comprises appreciable quantities of alkali metals such as potassium and magnesium; at the expected temperatures of the fuel reactor,

these ash species may melt and agglomerate, possibly resulting in defluidisation of the bed, or may react and contaminate the oxygen carrier.

The biomass feedstock should be suitably prepared for CLC. Minimising moisture content increases the calorific value of the fuel, but also prevents the oxidation of the oxygen carrier by steam released during gasification, thereby improving the purity of the captured CO<sub>2</sub> stream. Depending on the reactivity of the biomass, the feedstock should be pulverised to a powder to increase gasification rates. Both of these processes are energy-intensive.

### ***Appropriate biomass feedstocks***

On this basis, biomass used in CLC should meet the following criteria:

- Low moisture content (ideally < 15-20%)
- High volatile content
- Low ash content

Suggested feedstocks for CLC are therefore:

- Forestry wood (e.g. pine, spruce)
- Short Rotation Coppice (SRC, e.g. poplar, willow)
- Untreated waste products (e.g. wood offcuts, sawdust)
- Dry agricultural residues (e.g. chicken litter)

### ***Maximum % co-firing allowable /dedicated biomass***

There has been increasing interest in the utilisation of biomass in CLC; feedstocks considered to-date include sawdust<sup>319,320,321,322,323</sup> and hybrid poplar<sup>324,325</sup>. The use of a fluidised bed for gasification / combustion provides versatility to the choice of feedstock; co-firing with coal is an eligible option, and may be one way of reducing the alkali metal content within the fuel reactor<sup>320</sup>. However, dedicated biomass operation should be feasible for feedstocks with low alkali metal ash content e.g. forestry wood, untreated waste wood, SRC.

### ***Ease of changing to co-firing/complete conversion***

Fluidised beds provide flexibility regarding feedstock, and so little modification of the plant is expected for raising the co-firing %, or switching to dedicated biomass conversion. Pre-processing for biomass co-firing > 15 % may require dedicated equipment, but this is not a unique problem to CLC.

### ***Implications for retrofitting to an existing power plant***

For existing coal and co-fired plants, CLC is unlikely to be retro-fittable, and would most likely require the commissioning of new plant builds. However, the UK is proposing a dramatic scale-up of biomass power generation, and the expected feedstocks (wood pellets/chips from forestry and SRC, waste wood) are all compatible with CLC. CFBs are the likely boiler technology for dedicated biomass combustion plants, in which case CLC may be retrofittable via the addition of a second CFB reactor.

**Table 2.17: Conversion technology compatibility with CLC**

Technology	Compatibility (1 = low, 5 = high)	Comments
Pulverised fuel combustion	1	
Fixed grate combustion	1	
BFB biomass combustion	3	Biomass must first be gasified in steam/CO <sub>2</sub>
CFB biomass combustion	3	Biomass must first be gasified in steam/CO <sub>2</sub>
BFB biomass gasification	4	Concurrent gasification and combustion of biomass and syngas. Rate of char gasification significantly enhanced with addition of oxygen carrier
CFB biomass gasification	5	As above, with additional advantage of increased char residence time
Dual biomass gasification	5	As above, plus the system already has two interconnected fluidised bed reactors (with one CFB)

- <sup>274</sup> Richter HJ, Knoche KF. Reversibility of combustion processes. ACS Symposium Series 1983;235:71-85.
- <sup>275</sup> CO<sub>2</sub> Capture Report. IEAGHG 2007. Accessed online 03/05/2011: <http://www.ieaghg.org/index.php?/General-Publications/>
- <sup>276</sup> Ryu H-J, Jin G-T. Chemical-looping hydrogen generation system: performance estimation and process selection. Korean J. Chem. Eng. 2007;24(3):527-531
- <sup>277</sup> Jin GT, Ryu H-J, Jo S-H, Lee S-Y, Son SR, Kim SD. Hydrogen production in fluidized bed by chemical-looping cycle. Korean J. Chem. Eng. 2007;24(3):542-546
- <sup>278</sup> Bohn CD, Müller CR, Cleeton JP, Hayhurst AN, Davidson JF, Scott SA, Dennis JS. Production of very pure hydrogen with simultaneous capture of carbon dioxide using the redox reactions of iron oxides in packed beds. Industrial & Engineering Chemistry Research 2008;47(20):7623-7630.
- <sup>279</sup> Rydén M, Lyngfelt A. Using steam reforming to produce hydrogen with carbon dioxide capture by chemical-looping combustion. International Journal of Hydrogen Energy 2006;31(10):1271-1283
- <sup>280</sup> Wiltowski T, Mondal K, Campen A, Dasgupta D, Konieczny A. Reaction swing approach for hydrogen production from carbonaceous fuels. International Journal of Hydrogen Energy 2008;33(1):293-302.
- <sup>281</sup> Chiesa P, Lozza G, Malandrino A, Romano M, Piccolo V. Three-reactors chemical looping process for hydrogen production. International Journal of Hydrogen Energy 2008;33(9):2233-2245
- <sup>282</sup> Lyngfelt A, Leckner B, Mattisson T. A fluidized-bed combustion process with inherent CO<sub>2</sub> separation; application of chemical-looping combustion. Chemical Engineering Science 2001;56(10):3101-3113
- <sup>283</sup> Abad A, Adánez J, García-Labiano F, de Diego LF, Gayán P. Modeling of the chemical-looping combustion of methane using a Cu-based oxygen-carrier. Combustion and Flame 2010;157(3):602-615
- <sup>284</sup> Abad A, Adánez J, García-Labiano F, de Diego LF, Gayán P, Celaya J. Mapping of the range of operational conditions for Cu-, Fe-, and Ni-based oxygen carriers in chemical-looping combustion. Chem Eng Science 2007;62(1-2):533-549
- <sup>285</sup> Lyngfelt A, Thunman H. Construction and 100 h of operational experience of a 10-kW chemical-looping combustor. In: Carbon dioxide capture for storage in deep geologic formations. Amsterdam: Elsevier Science, 2005. p. 625-645
- <sup>286</sup> Berguerand N. Design and Operation of a 10 kW<sub>th</sub> Chemical-Looping Combustor for Solid Fuels. Chalmers University of Technology, 2009
- <sup>287</sup> Berguerand N, Lyngfelt A. Design and operation of a 10 kW<sub>th</sub> chemical-looping combustor for solid fuels - testing with South African coal. Fuel 2008;87(12):2713-2726.
- <sup>288</sup> Linderholm C, Mattisson T, Lyngfelt A. Long-term integrity testing of spray-dried particles in a 10-kW chemical-looping combustor using natural gas as fuel. Fuel 2009;88(11):2083-2096
- <sup>289</sup> Kolbitsch P, Pröll T, Bolhar-Nordenkampf J, Hofbauer H. Operating experience with chemical looping combustion in a 120 kW dual circulating fluidized bed (DCFB) unit. Energy Procedia 2009;1(1):1465-1472
- <sup>290</sup> Fachgebiet energiesysteme und energietechnik, prof. dr.-ing. Bernd Epple. Accessed online 29/04/2011: <http://www.est.tu-darmstadt.de/index.php/en/co2-versuchsfeld>
- <sup>291</sup> Herbert Jr A, Chiu J, Thibeault P, Brautsch A. Alstom's calcium oxide chemical looping combustion coal powertechnology development. In: The 34th international technical conference on clean coal & fuel systems. Florida, U.S.A.: 2009
- <sup>292</sup> Jerndal E, Mattisson T, Lyngfelt A. Thermal analysis of chemical-looping combustion. Chemical Engineering Research and Design 2006;84(9):795-806
- <sup>293</sup> Kolbitsch P, Pröll T, Bolhar-Nordenkampf J, Hofbauer H. Operating experience with chemical looping combustion in a 120 kW dual circulating fluidized bed (DCFB) unit. Energy Procedia 2009;1(1):1465-1472
- <sup>294</sup> Cho P, Mattisson T, Lyngfelt A. Comparison of iron-, nickel-, copper- and manganese-based oxygen carriers for chemical-looping combustion. Fuel 2004;83(9):1215-1225



- <sup>295</sup> Ishida M, Zheng D, Akehata T. Evaluation of a chemical-looping-combustion power-generation system by graphic exergy analysis. *Energy* 1987;12(2):147-154
- <sup>296</sup> Anheden M, Svedberg G. Exergy analysis of chemical-looping combustion systems. *Energy Conversion and Management* November;39(16-18):1967-1980.
- <sup>297</sup> Naqvi R, Bolland O. Multi-stage chemical looping combustion (CLC) for combined cycles with CO<sub>2</sub> capture. *International Journal of Greenhouse Gas Control* 2007;1(1):19-30.
- <sup>298</sup> Cleeton JPE, Bohn CD, Müller CR, Dennis JS, Scott SA. Clean hydrogen production and electricity from coal via chemical looping: identifying a suitable operating regime. *International Journal of Hydrogen Energy* 2009;34(1):1-12
- <sup>299</sup> Li F, Zeng L, Fan L-S. Biomass direct chemical looping process: process simulation. *Fuel* 2010;89(12):3773-3784
- <sup>300</sup> Kobayashi N, Fan L-S. Biomass direct chemical looping process: a perspective. *Biomass & Bioenergy* 2011;35(3):1252-1262
- <sup>301</sup> Petrakopoulou F, Boyano A, Cabrera M, Tsatsaronis G. Exergoeconomic and exergoenvironmental analyses of a combined cycle power plant with chemical looping technology. *International Journal of Greenhouse Gas Control* 2011;In Press, Corrected Proof
- <sup>302</sup> Power Systems evaluation and benchmarking. ENCAP WP1.2 Deliverable 1.2.4 Public Version. Accessed online 12/06/2011: [http://www.encapco2.org/publications/D\\_1\\_2\\_4\\_SummaryReport.pdf](http://www.encapco2.org/publications/D_1_2_4_SummaryReport.pdf)
- <sup>303</sup> Galvita V, Sundmacher K. Cyclic water gas shift reactor (CWGS) for carbon monoxide removal from hydrogen feed gas for pem fuel cells. *Chemical Engineering Journal* 2007;134(1-3):168-174.
- <sup>304</sup> Galvita V, Sundmacher K. Hydrogen production from methane by steam reforming in a periodically operated two-layer catalytic reactor. *Applied Catalysis A: General* 2005;289(2):121-127.
- <sup>305</sup> Commodity prices. Index Mundi 2011
- <sup>306</sup> Fossdal A, Bakken E, Øye BA, Schønning C, Kaus I, Mokkelbost T, Larring Y. Study of inexpensive oxygen carriers for chemical looping combustion. *International Journal of Greenhouse Gas Control* 2010;In Press, Corrected Proof.
- <sup>307</sup> Leion H, Mattisson T, Lyngfelt A. Use of ores and industrial products as oxygen carriers in chemical-looping combustion. *Energy & Fuels* 2009;23(4):2307-2315
- <sup>308</sup> Leion H, Mattisson T, Lyngfelt A. The use of petroleum coke as fuel in chemical-looping combustion. *Fuel* 2007;86(12-13):1947-1958
- <sup>309</sup> Berguerand N, Lyngfelt A. Design and operation of a 10 kW<sub>th</sub> chemical-looping combustor for solid fuels - testing with South African coal. *Fuel* 2008;87(12):2713-2726
- <sup>310</sup> Yang J-biao, Cai N-sheng, Li Z-shan. Reduction of iron oxide as an oxygen carrier by coal pyrolysis and steam char gasification intermediate products. *Energy & Fuels* 2007;21(6):3360-3368
- <sup>311</sup> Scott SA, Dennis JS, Hayhurst AN, Brown T. In situ gasification of a solid fuel and co<sub>2</sub> separation using chemical looping. *AIChE J.* 2006;52(9):3325-3328
- <sup>312</sup> Berguerand N, Lyngfelt A. The use of petroleum coke as fuel in a 10 kW<sub>th</sub> chemical-looping combustor. *International Journal of Greenhouse Gas Control* 2008;2(2):169-179
- <sup>313</sup> Leion H, Mattisson T, Lyngfelt A. Solid fuels in chemical-looping combustion. *International Journal of Greenhouse Gas Control* 2008;2(2):180-193.
- <sup>314</sup> Dennis JS, Scott SA. In situ gasification of a lignite coal and CO<sub>2</sub> separation using chemical looping with a cu-based oxygen carrier. *Fuel* 2010;89(7):1623-1640
- <sup>315</sup> Bridgwater AV. Progress in thermochemical biomass conversion. In: *Progress in thermochemical biomass conversion*, vol. 1. Wiley-Blackwell, 2001. p. 32-46.
- <sup>316</sup> Yang J-biao, Cai N-sheng, Li Z-shan. Hydrogen production from the steam-iron process with direct reduction of iron oxide by chemical looping combustion of coal char. *Energy & Fuels* 2008;22(4):2570-2579
- <sup>317</sup> Adánez J, Dueso C, de Diego LF, García-Labiano F, Gayán P, Abad A. Effect of fuel gas composition in chemical-looping combustion with ni-based oxygen carriers. 2. Fate of light hydrocarbons. *Industrial & Engineering Chemistry Research* 2009;48(5):2509-2518
- <sup>318</sup> Gayán P, Forero CR, de Diego LF, Abad A, García-Labiano F, Adánez J. Effect of gas composition in chemical-looping combustion with copper-based oxygen carriers: fate of light hydrocarbons. *International Journal of Greenhouse Gas Control* 2010;4(1):13-22
- <sup>319</sup> Shen L, Wu J, Xiao J, Song Q, Xiao R. Chemical-looping combustion of biomass in a 10 kW<sub>th</sub> reactor with iron oxide as an oxygen carrier. *Energy & Fuels* 2009;23(5):2498-2505
- <sup>320</sup> Gu H, Shen L, Xiao J, Zhang S, Song T. Chemical looping combustion of biomass/coal with natural iron ore as oxygen carrier in a continuous reactor. *Energy & Fuels* 2011;25(1):446-455
- <sup>321</sup> Shen L, Wu J, Xiao J, Song Q, Xiao R. Chemical-looping combustion of biomass in a 10 kW<sub>th</sub> reactor with iron oxide as an oxygen carrier. *Energy & Fuels* 2009;23(5):2498-2505
- <sup>322</sup> Acharya B, Dutta A, Basu P. Chemical-looping gasification of biomass for hydrogen-enriched gas production with in-process carbon dioxide capture. *Energy & Fuels* 2009;23(10):5077-5083
- <sup>323</sup> Acharya B, Dutta A, Basu P. Chemical-looping gasification of biomass for hydrogen-enriched gas production with in-process carbon dioxide capture. *Energy & Fuels* 2009;23(10):5077-5083
- <sup>324</sup> Kobayashi N, Fan L-S. Biomass direct chemical looping process: a perspective. *Biomass and Bioenergy* 2011;In Press, Corrected Proof
- <sup>325</sup> Li F, Zeng L, Fan L-S. Biomass direct chemical looping process: process simulation. *Fuel* 2010;89(12):3773-3784

### 2.3.10 Pre-combustion: IGCC with solvent absorption

The Integrated Gasification Combined Cycle (IGCC) process including CO<sub>2</sub> capture via solvent absorption has the same four main steps as detailed in Section 2.2.2 for an IGCC plant without capture, but now with three important additions<sup>326</sup>:

- Water-gas-shift (WGS) reactor, and possible Steam Methane Reforming (SMR)
- Solvent absorption of CO<sub>2</sub> and regeneration
- Drying and compression of CO<sub>2</sub>

The new plant configuration is shown in Figure 2.31.

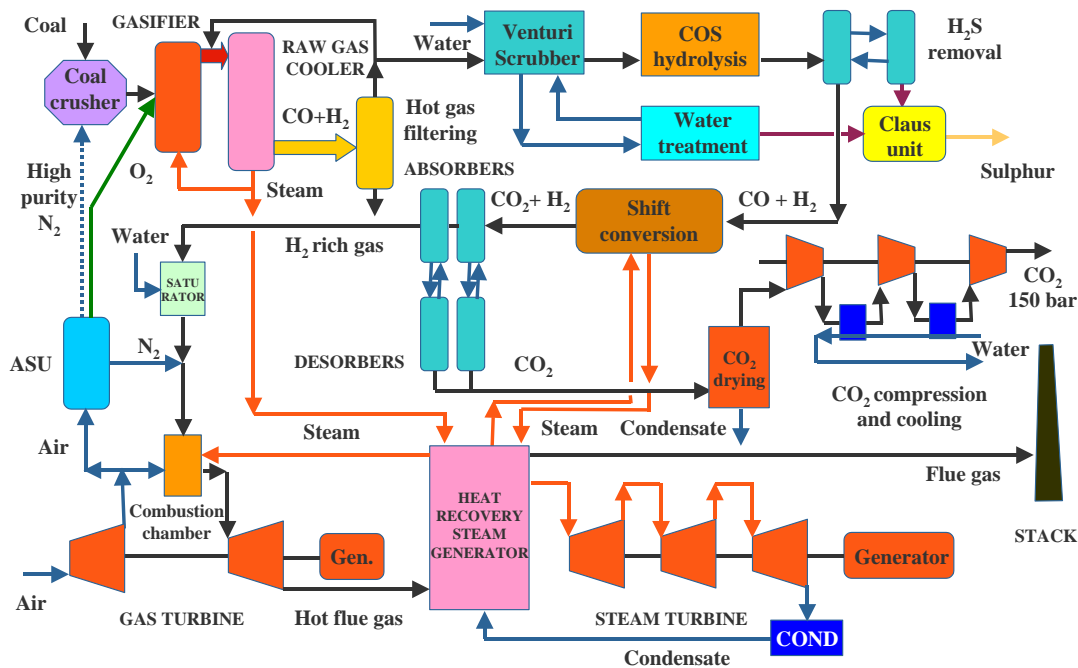

Figure 2.31: Generic schematic of an IGCC plant with CO<sub>2</sub> capture

To increase the CO<sub>2</sub> capture rate, first the majority of the CO in the syngas needs to be converted into CO<sub>2</sub>. This operation is performed in catalyst reactors where CO reacts with steam to produce CO<sub>2</sub> and H<sub>2</sub> via a water-gas-shift reaction – thereby increasing CO<sub>2</sub> concentrations for capture, and increasing H<sub>2</sub> concentrations for power generation. However, this process depends on the efficiency of the WGS reactor – at least two reactors in series, at different temperatures, are usually necessary to achieve a high CO to CO<sub>2</sub> conversion rate of around 95%. Even higher conversion rates could be achieved (97%<sup>327</sup>) if more reactors were added in series, although there are rapidly diminishing returns available. The Low-Temperature Shift (LTS) catalyst is very sensitive to sulphur and chloride poisoning, whereas the High-Temperature Water-Gas-Shift (HTS) catalysts can tolerate sulphur concentrations up to several hundred ppm, although the activity will decline. Other HTS catalyst poisons include phosphorus, silicon and unsaturated hydrocarbons in the presence of NO<sub>x</sub>.

If syngas methane concentrations are too high, a steam-methane reforming (SMR) process can be included to convert any methane to additional H<sub>2</sub> and CO<sub>2</sub>, although this imposes a cost and efficiency penalty on the system. The key poison to avoid in this reaction is sulphur: feed gas concentrations <0.5 ppm are needed<sup>328</sup>. The simplest option prior to the steam reformer is to have a

hydrogenator where sulphur compounds are converted to H<sub>2</sub>S, then a ZnO bed to absorb H<sub>2</sub>S in the feed gas. However, state-of-the-art in acid gas removal is the use of physical solvents. These processes are cost-effective when used for large-scale fossil syngas cleaning, although relevant scales for viable biosyngas processes are not yet known.

As CO<sub>2</sub> is also an acid gas, CO<sub>2</sub> is then captured as it is done for H<sub>2</sub>S with chemical solvents (amines) or physical solvents (Selexol™, Rectisol™). The developers of the CO<sub>2</sub> capture processes, such as UOP with their Selexol™ technology, nowadays also offer combined processes in order to remove H<sub>2</sub>S and CO<sub>2</sub> simultaneously. The target market for this technology is new IGCC plants designed for pre-combustion CO<sub>2</sub> capture.

Captured CO<sub>2</sub> is then dried down to 20 ppm and compressed, ready for transport in a supercritical state to a suitable storage site.

A typical CO<sub>2</sub> absorption/regeneration process is shown in Figure 2.32. The gas to be treated is first cooled in a heat exchanger, then injected at the bottom of the absorption column. The heat exchanger also serves the function of heating the treated gases after they leave the column. Depending on the process type (e.g. for methanol-Rectisol™, NMP and Selexol™ processes), the gas is chilled in a second step using a refrigeration system: this increases physical absorption capacity and limits volatile losses of the solvent. After having been cooled to a similar temperature as the chilled syngas, the lean solvent is injected at the top of the absorption column to absorb the CO<sub>2</sub> from the syngas. The CO<sub>2</sub> rich solvent exiting the absorber is then heated by exchanging heat with the lean solvent coming from the regeneration column. The solvent is regenerated in desorption column, using the heat provided by low-pressure steam condensation in the reboiler.

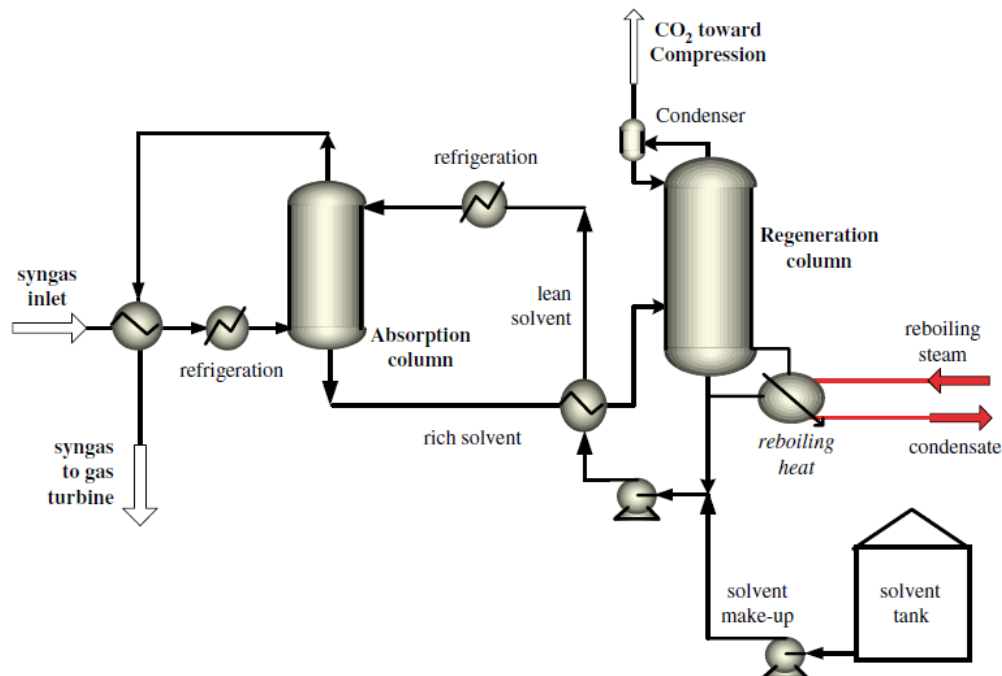
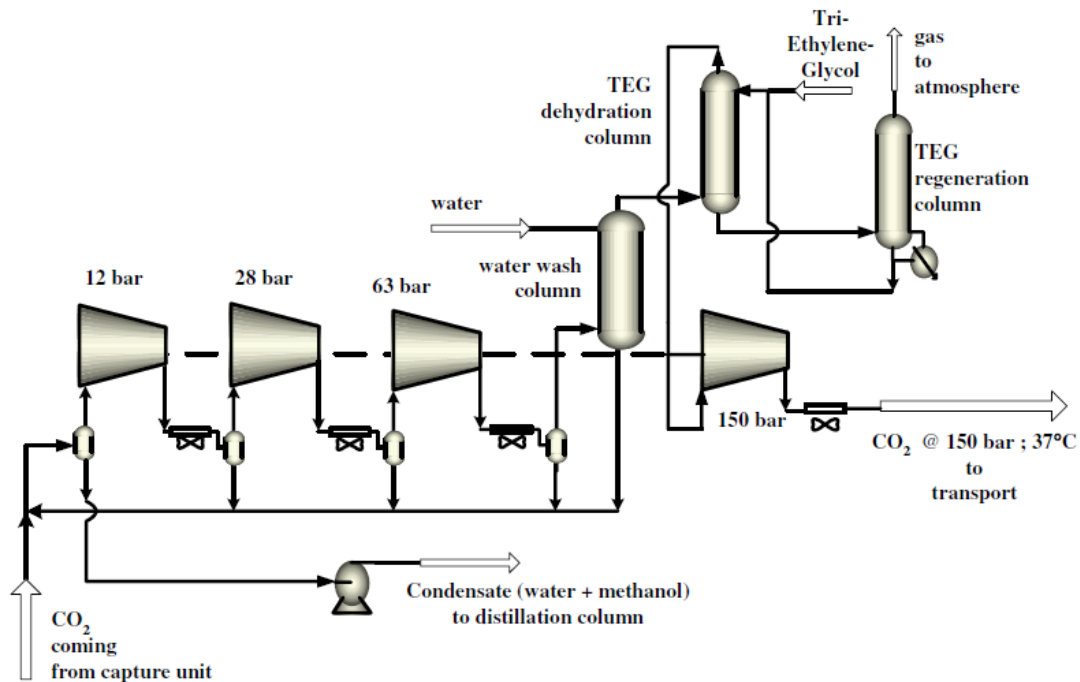

**Figure 2.32: Typical absorption process for pre-combustion CO<sub>2</sub> capture**

Physical solvents such as methanol (Rectisol™, Lurgi), propylene carbonate (PC, Fluor), N-methylpyrrolidone (NMP, Lurgi), Dimethylether of polyethylene glycol (Selexol™, UOP) are known for their chemical stability and for a non-induced corrosion effect. Moreover, their high absorption capacities

make them interesting for bulk removal. In order to increase their absorption capacity of CO<sub>2</sub>, physical solvents need generally chilling. Methanol requires the greatest level of refrigeration, due to its high volatility. In addition, the Flexisorb and Sulfinol processes employing a combination of chemical and physical solvents are also successfully practiced.

High solvent volatility is a disadvantage, due to the potential for solvent losses from the system. Even with process chilling to -30 °C, it is necessary, before the transport and the storage of the captured CO<sub>2</sub>, to add to the CO<sub>2</sub> compression unit a wash water column to capture entrained methanol within the CO<sub>2</sub> stream, as shown in Figure 2.33.



**Figure 2.33: Compression unit including methanol recovery and TEG dehydration system**

For the CO<sub>2</sub> transportation, the water content should not exceed 20 ppm to avoid corrosion problems. For this purpose, a dehydration system based on triethylene-glycol (TEG) is added in the compression unit. For methanol recovery from the condensed water, a distillation column is also added to the CO<sub>2</sub> capture unit, as shown in the overall system configuration in Figure 2.34. The recovered methanol is recycled back into the regeneration column. Figure 2.34 is an illustration of a typical CO<sub>2</sub> capture process based on chilled methanol – although we note that any similarities to Rectisol™ are not known, as there are very few details regarding Rectisol™ in the public domain. Both syngas and solvent are chilled (-20°C to -30°C) upstream the absorption column.

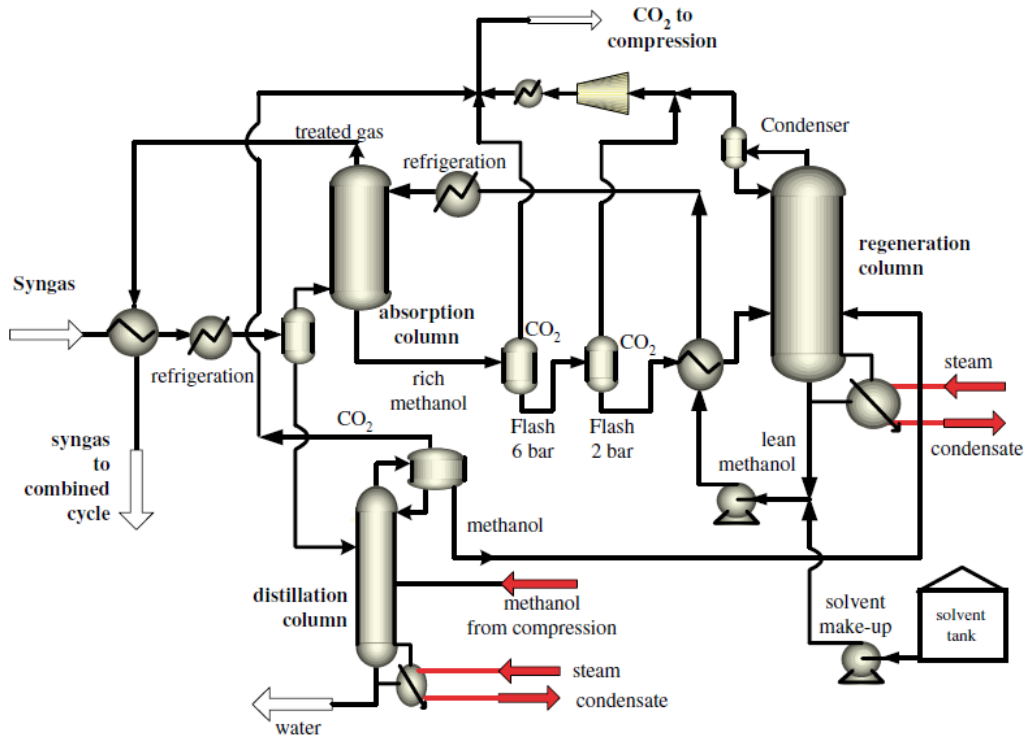

**Figure 2.34: Overall typical chilled methanol process for CO<sub>2</sub> capture, including distillation column for methanol recovery from condensation water of compressed CO<sub>2</sub> stream**

The rich solvent is regenerated partially by successive flashing before deep regeneration in regeneration column. This type of process needs, before CO<sub>2</sub> capture, a water-gas shift catalysis and desulfuration of syngas.

Figure 2.35 gives a process model of Selexol™ suitable for both H<sub>2</sub>S and CO<sub>2</sub> capture<sup>329</sup>. As H<sub>2</sub>S and CO<sub>2</sub> are both acid gases, they will compete for solvent absorption. A minimum H<sub>2</sub>S concentration needs to be maintained in the Acid gas stream, so that the downstream Claus unit can continue to recover pure sulphur. In order to ensure this occurs, it is necessary to add a partial regeneration column (H<sub>2</sub>S concentrator). By recycling H<sub>2</sub>S gas back into the H<sub>2</sub>S absorption column, the ratio of CO<sub>2</sub> over H<sub>2</sub>S decreases in the H<sub>2</sub>S absorption column, which limits the CO<sub>2</sub> amount entrained in the solvent. Elsewhere, because of very high ratio of CO<sub>2</sub> over H<sub>2</sub>S after water-gas shift reactions, and even with good solvent selectivity, a large amount of CO<sub>2</sub> is regenerated in the acid gas at the same time as H<sub>2</sub>S in the H<sub>2</sub>S stripper, leading to a less efficient design for the Claus unit (due to too much dilution of the reactive element H<sub>2</sub>S).

A third of the output H<sub>2</sub>S stream is oxidised to form SO<sub>2</sub>, so that the Claus unit can then convert the remaining two-thirds of the H<sub>2</sub>S into pure sulphur ( $2 \text{H}_2\text{S} + \text{SO}_2 \rightarrow \text{S} + 2 \text{H}_2\text{O}$ ). H<sub>2</sub>S regenerated solvent is recycled in the CO<sub>2</sub> absorption column. CO<sub>2</sub> solvent could be regenerated by successive flashing or by adding a stripper to allow a high rate of CO<sub>2</sub> capture

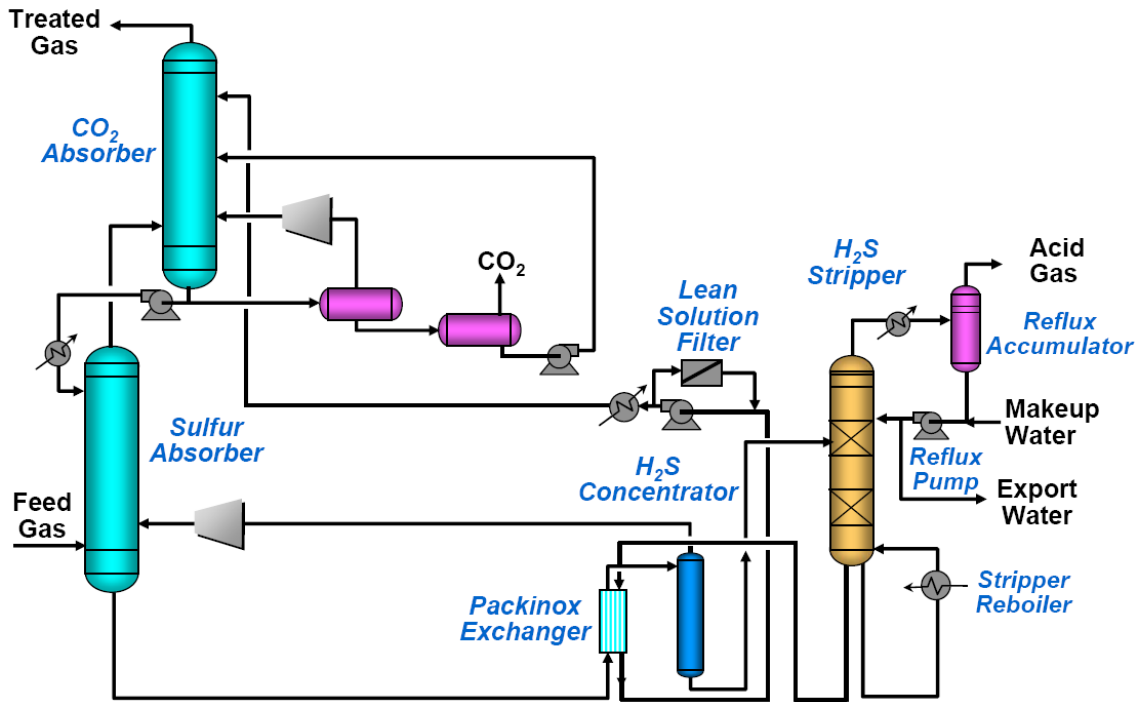

Figure 2.35: Selexol™ process for both H<sub>2</sub>S and CO<sub>2</sub> capture including distillation column for methanol recovery<sup>329</sup>

### Development aspects and prospects

#### Key drivers, Technology Readiness Level

Pre-combustion capture is actually the most mature of all the CO<sub>2</sub> capture technologies, including post-combustion amine scrubbing. Pre-combustion capture is even more mature than IGCC power generation technology itself, because it has gained many years of operational experience in numerous chemical plants (although with no or very little integration with energy production). These applications include natural gas desulfuration and decarbonation processes, as well as processes involved in the production of hydrogen, ammonia and other process gases.

Pre-combustion capture has further some advantages over post-combustion capture, due to the similarity between IGCC syngas and chemical plants gases (i.e. high pressure, minimal dust, absence of O<sub>2</sub>, SO<sub>2</sub>, NO<sub>2</sub> and other pollutants specific to coal or gas complete combustion, e.g. NO<sub>x</sub>).

Therefore, the TRL of only the CO<sub>2</sub> capture component as applied to pre-combustion capture from syngas could be assessed to be TRL 9 currently, and hence also likely to be at TRL 9 in 2020.

#### Key development issues

Due to the advanced commercialisation of several competing pre-combustion capture technologies, and widespread deployment in a range of applications, there are few key technical issues or barriers remaining to be solved. However, there is currently lack of experience in integrating a pre-combustion capture system with a power generation system at a commercial scale. The majority of pre-combustion capture applications to date have been in the chemicals industry, not the power

sector. However, the relevant experience should be gained as different capture systems are deployed with a new fleet of coal IGCC demonstrations.

As for IGCC plants without capture, there is also a need to develop higher efficiency gas turbines, but modified to use H<sub>2</sub>-rich gas (and not just syngas). Premix mode developments (mixing fuel and air before combustion) could avoid the need for nitrogen dilution, which could also save up to 1%-point in overall plant efficiency.

### ***Implications of retrofitting capture vs. new build***

Significant modifications are required in addition to the new WGS and CO<sub>2</sub> capture equipment. One key change is in the operation of the gas turbine, as the fuel supplied to it is now much richer in hydrogen. Other changes compared to IGCC without CO<sub>2</sub> capture are the need for a larger (by about 10%) gasification and air separation capacities, and changes in the steam flows in the steam cycle.

Significant pre-planning will be required to make IGCC plants capture ready<sup>326</sup>:

- Key is the careful selection of the gas turbine design, since it should be able to run efficiently on both syngas and hydrogen-rich fuel
- The pipe-work before the turbine will also have to cope with altered mass-flows
- Provisions must be made for higher ASU and gasification capacity that is needed post-capture (if the same MW<sub>e</sub> output is to be maintained)
- Footprint space for WGS reactors, CO<sub>2</sub> capture and compression equipment
- Flexibility in steam cycle design to handles any changes due to CO<sub>2</sub> capture

Unlike with post-combustion capture, shutting down the downstream CCS parts still leaves a less efficient plant than without capture, because the WGS reactors decrease efficiency. One way around this issue would be to use a double syngas path, i.e. duplicating all the equipment between the gas cleaning unit and gas turbine, so that the additional water-gas-shift reactor, H<sub>2</sub> separation, and saturator (if necessary for low NO<sub>x</sub> emissions) were on one path, and the original syngas still able to flow on a separate path. This would save the plant efficiency when CCS operations were stopped, but at high additional equipment costs.

It is because of these substantial design and operational modifications, and permanent efficiency losses, that retrofitting existing inefficient IGCC plants with CO<sub>2</sub> capture, although technically possible, is considered by some industry experts to be largely impractical – and that new build, high efficiency IGCC plants with CCS already included are a much more attractive option.

### ***Main players internationally***

Physical solvent absorption systems are commercially supplied by Lurgi, UOP, Fluor. Combined IGCC-CCS systems are being investigated by University of Texas and NETL (USA), Regina Univ. (Canada), TNO (Netherlands), Sintef (Norway), and CSIRO (Australia).

### ***UK activities and capabilities***

Currently, there are no IGCC plants in the UK. Therefore, biomass co-firing as for the UK's pulverised coal fleet is not currently possible, nor is the conversion of an existing plant to 100% biomass.

However, as part of the EU's NER300 competition<sup>330</sup>, the UK has very recently entered seven CCS project applications, with three involving new IGCC plants in North East England:

- C.GEN are planning a new 520MW<sub>e</sub> plant in Killingholme, Yorkshire, and may co-fire up to 30% biomass or petcoke. Plan to enter operation in 2015<sup>331</sup>
- Don Valley Power Project: 900MW<sub>e</sub> coal IGCC power station in Stainforth, Yorkshire, plans to commission in 2016. This was formerly the Hatfield Project, until Powerfuel Power Limited were bought out by 2Co Energy in May 2011<sup>332</sup>
- Teeside CCS project: consortium led by Progressive Energy Ltd, and plans to build a 850 MW<sub>e</sub> IGCC on a brown-field site at Eston Grange, and store the CO<sub>2</sub> offshore<sup>333</sup>

Therefore, provided that at least one of these projects receives NER300 funding and goes ahead, UK capabilities and expertise in IGCC with capture will increase significantly before 2020. Rio Tinto Alcan have also been planning converting one of the PCC boilers at their Lynemouth power plant into an IGCC unit with capture.

### ***Environmental factors***

IGCC without capture is characterised by very low pollutant emission comparatively to standard pulverised coal combustion: fewer dust, sulphur and NO<sub>x</sub> emissions, and lower or almost similar water usage depending on gasifier type. By adding CO<sub>2</sub> absorption, some emissions such as dust, sulphur are even lower. Using physical solvents presents some risk of emission of hydrocarbons through solvent evaporation, but these risks could be easily controlled by flue gas washing.

Chemical solvents need more complex handling requirements, as degraded amines could be toxic (see post-combustion solvent scrubbing in Section 2.3.1). However, for IGCC, amine degradation is expected to be very limited as NO<sub>2</sub>, SO<sub>2</sub> and O<sub>2</sub>, which are the main precursors to amine degradation, are not present in cleaned syngas. Furthermore, physical solvents are usually preferred for IGCC applications since syngas pressures and CO<sub>2</sub> concentrations are high enough to realise significant cost savings over chemical solvents.

### ***Technical and economics characteristics***

#### ***Equipment scales***

Physical absorption is already being used at scale for syngas H<sub>2</sub>S removal in power applications. Using the same system for CO<sub>2</sub> capture only requires a slightly larger capacity. Therefore, the scale of an IGCC plant with capture is more likely to be determined by the IGCC power plant.

Even with combined cycle generation units commercially available today at 50 MW<sub>e</sub>, coal IGCC commercial plant sizes will likely be between 250 and 1,200 MW<sub>e</sub> to enable economies of scale, and keep the high capital costs as low as possible. Therefore, co-firing biomass in a coal IGCC with capture is not likely to be suitable for small scale applications. Dedicated biomass IGCC have different scale constraints, since economies of scale in plant capital costs are quickly offset by increases in biomass provision costs – hence dedicated BIGCC with capture might be applicable for small scale applications, although this remains to be demonstrated.



### ***Flexibility***

IGCC plants are complex to operate, have slow response times and have long start-up times from cold (~24hours). There are also large efficiency losses when operating at partial load. The addition of a WGS reactor, physical CO<sub>2</sub> absorption cycle, CO<sub>2</sub> purification and compression is also likely to negatively impact the plant flexibility. IGCC technology in its current configuration, with or without capture, is not suitable for peak load operation. Increasing plant flexibility would incur substantial costs, e.g. by using more expensive air separation units (with faster ramp rates), using pre-heating equipment for faster start-ups, as well as incurring lower capacity factors for what is already a high capex plant.

An alternative plant configuration, under consideration for applications within a future hydrogen economy, would be to run the high-capex gasifier at full load, but then store the H<sub>2</sub> produced after capture. This buffer storage could then supply H<sub>2</sub> on demand for combustion in a much larger gas turbine combined cycle plant, i.e. highly flexible peaking power could be produced. Any additional H<sub>2</sub> would also be sold as a co-product. It is worth noting that the ability to load follow has more value in certain power markets than others (depending on spot price differentials and the generation mix), and this benefit could be offset by the extra costs of storage, and reduced turbine capacity factors.

Currently, with gas turbines requiring high purity N<sub>2</sub>, a separate storage facility for the N<sub>2</sub> produced from the ASU would also be required. However, in the future, gas turbine developments using premix mode (without N<sub>2</sub> dilution) would negate the need for this separate storage.

### ***Efficiency with capture***

The efficiency loss due to pre-combustion capture depends on the gasifier type, the type of coal, and the combined cycle unit adaptability. The relative decrease of efficiency due to CO<sub>2</sub> capture is about 20% for bituminous coal and about 21% for lignite<sup>334</sup>. This is to be compared to a relative loss of efficiency of 25% for PCC with capture. In other term, IGCC with capture losses about 8%-points efficiency compared to 10%-points lost in post- and oxy-combustion.

Given that a baseline coal combustion plant efficiency is close to 45%, with post- or oxy-combustion capture, this falls to around 35%. IGCC baseline plant efficiency will be between 50% and 55% with the most modern gas turbines recently developed, hence the plant efficiency with capture is expected to be between 42% and 47% - i.e. similar to combustion plants *without* capture. In summary, not only are IGCC plant baseline efficiencies higher, the capture efficiency penalty is also smaller, leading to significantly higher efficiencies than combustion systems with capture.

### ***CO<sub>2</sub> capture rate***

The optimal CO<sub>2</sub> capture rate using physical or chemical solvents is almost 90%, although could reach 95% before very steep increases in energy consumption are required to increase the capture rate further. However, globally it is expected that a capture rate of between 85 – 90% will be the most likely configuration choice, based on an economic and emissions optimisation.

### ***Economics***

Building on the IGCC with capture economics given in Section 2.2.2, the IEA meta-review<sup>334</sup> shows in Table 2.18 that adding CO<sub>2</sub> capture to an IGCC plant only leads to an increase of 44% in capital costs (from 2,586 up to 3,714 \$/kW<sub>e</sub>), whilst it induces an increase of 63% in PCC (from 2,162 up to 3,808

\$/kW<sub>e</sub>). Converting to £2011, these costs with capture for IGCC and PCC are 2,358 and 2,398 £<sub>2011</sub>/kW<sub>e</sub> respectively. Therefore, although IGCC plants without capture are more expensive than PCC plants without capture, once the costs of CO<sub>2</sub> capture are added, capital costs are similar.

The operating costs of a coal IGCC plant with capture are 100 to 135 \$/kW<sub>e</sub>/yr (75 – 102 £/kW<sub>e</sub>/yr).

The LCOE increase due to adding capture is only about 40% for IGCC (up to 104 \$/MWh, or £66/MWh on average), compared to a 62% increase in PCC with capture (up to 107 \$/MWh, or £68/MWh). This data shows that IGCC can also compete with PCC on the cost of electricity generated, if CO<sub>2</sub> capture technologies are included.

As already noted in Section 2.2.2, large-scale fossil fuel power plant capital costs have more than doubled in the seven years from 2003 to 2007, and fluctuated since. Although the absolute values may change, this is unlikely to significantly modify the relative positions of PCC and IGCC plants, with or without CO<sub>2</sub> capture.

**Table 2.18: Pre-combustion capture from IGCC power plants<sup>334</sup>**

Regional focus	OECD										China	Average (OECD)
Year of cost data	2005	2005	2005	2007	2007	2007	2008	2008	2008	2009	2009	
Year of publication	2007	2007	2007	2010	2010	2010	2009	2009	2009	2009	2009	
Organisation	MIT	GHG IA	GHG IA	NETL	NETL	NETL	CMU	EPRI	EPRI	GCCSI	NZEC	
<b>ORIGINAL DATA AS PUBLISHED (converted to USD)</b>												
Region	US	EU	EU	US	US	US	US	US	US	US	CHN	
Specific fuel type	Bit coal	Bit coal	Bit coal	Bit coal	Bit coal	Bit coal	Bit coal	Sub-bit coal	Bit coal	Bit coal	Bit coal	
Power plant type	GE	Shell	GE Quench	GE R+Q	CoP E-Gas FSQ	Shell	GE Quench	(Generic)	(Generic)	Shell IGCC	TPRI	
Net power output w/o capture (MW)	500	776	826	622	625	629	538	573	603	636	-	633
Net power output w/ capture (MW)	500	676	730	543	514	497	495	482	507	517	662	546
Net efficiency w/o capture, LHV (%)	40.3	43.1	38.0	40.9	41.7	44.2	40.0	41.0	41.2	43.2	-	41.4
Net efficiency w/ capture, LHV (%)	32.7	34.5	31.5	34.3	32.6	32.8	34.5	32.3	32.3	33.6	36.8	33.1
CO <sub>2</sub> emissions w/o capture (kg/MWh)	832	763	833	782	776	723	819	845	805	753	-	793
CO <sub>2</sub> emissions w/ capture (kg/MWh)	102	142	152	93	98	99	94	141	135	90	95	115
Capital cost w/o capture (USD/kW)	1 430	1 613	1 439	2 447	2 351	2 716	1 823	3 239	2 984	3 521	-	2 356
Capital cost w/ capture (USD/kW)	1 890	2 204	1 815	3 334	3 466	3 904	2 513	4 221	3 940	4 373	1 471	3 166
Relative decrease in net efficiency	19%	20%	17%	16%	22%	26%	14%	21%	22%	22%	-	20%
<b>RE-EVALUATED DATA (2010 USD)</b>												
Overnight cost w/o capture (USD/kW)	2 009	1 970	1 758	2 663	2 559	2 956	1 551	3 702	3 410	3 279	-	2 586
Overnight cost w/ capture (USD/kW)	2 834	2 874	2 367	3 874	4 027	4 536	2 323	5 150	4 808	4 348	1 721	3 714
LCOE w/o capture (USD/MWh)	62	69	75	76	73	81	52	86	92	88	-	75
LCOE w/ capture (USD/MWh)	83	102	95	104	109	120	71	118	126	115	73	104
Cost of CO <sub>2</sub> avoided (USD/tCO <sub>2</sub> )	29	53	30	42	53	62	26	45	51	41	-	43
Cost of CO <sub>2</sub> avoided vs PC baseline (USD/tCO <sub>2</sub> )	18	53	38	57	64	86	28	64	79	64	32	55
Relative increase in overnight cost	41%	46%	35%	45%	57%	53%	50%	39%	41%	33%	-	44%
Relative increase in LCOE	35%	48%	27%	38%	49%	48%	37%	37%	37%	31%	-	39%

Notes: Data cover only CO<sub>2</sub> capture and compression but not transportation and storage. Overnight costs include owner's, EPC and contingency costs, but not IDC. A 15% contingency based on EPC cost is added for unforeseen technical or regulatory difficulties for CCS cases, compared to a 5% contingency applied for non-CCS cases. IDC is included in LCOE calculations. Fuel price assumptions differ between regions. Generic data shown for EPRI; further details for individual gasifier designs, including data for Siemens gasifiers are available in EPRI (2009).

- 
- <sup>326</sup> Shah, M. (2007) "Advanced Clean Coal Technologies for CO<sub>2</sub> capture", available at: [http://www.praxair.com/praxair.nsf/AllContent/3051E72FBAB659DC8525737800667F96/\\$File/Shah%20-%20Praxair%20-%20CO2%20Capture%20-%20Pittsburgh%20Coal%20Conf%202006.pdf](http://www.praxair.com/praxair.nsf/AllContent/3051E72FBAB659DC8525737800667F96/$File/Shah%20-%20Praxair%20-%20CO2%20Capture%20-%20Pittsburgh%20Coal%20Conf%202006.pdf)
- <sup>327</sup> Descamps C., Bouallou C., and M. Kanniche (2008) "Efficiency of an Integrated Gasification Combined Cycle (IGCC) power plant including CO<sub>2</sub> removal", Energy, vol. 33.
- <sup>328</sup> Spath, P.L. and D.C. Dayton (2003) "Preliminary Screening — Technical and Economic Assessment of Synthesis Gas to Fuels and Chemicals with Emphasis on the Potential for Biomass-Derived Syngas" Report for NREL/TP-510-34929
- <sup>329</sup> UOP (2011) "Selexol technology for acid gas removal", available at: <http://www.uop.com/wp-content/uploads/2011/02/UOP-Selexol-Technology-for-Acid-Gas-Removal-tech-presentation.pdf>
- <sup>330</sup> DECC "Cutting-Edge UK Energy Projects in Running for EU funding", accessed 15<sup>th</sup> June 2011, available at: [http://www.decc.gov.uk/en/content/cms/news/pn11\\_39/pn11\\_39.aspx](http://www.decc.gov.uk/en/content/cms/news/pn11_39/pn11_39.aspx)
- <sup>331</sup> C-GEN, "Projects - Killingholme", accessed 15th June 2011, available at: [http://www.cgenpower.com/en/projects\\_killingholme.html](http://www.cgenpower.com/en/projects_killingholme.html)
- <sup>332</sup> 2Co Energy, "Don Valley Power Project", accessed 15th June 2011, available at: [http://www.2coenergy.com/don\\_valley\\_power\\_project.html](http://www.2coenergy.com/don_valley_power_project.html)
- <sup>333</sup> Progressive Energy "Welcome", accessed 15<sup>th</sup> June 2011, available at: <http://www.progressive-energy.com/>
- <sup>334</sup> Finkenrath M. (2011) "Cost and Performance of Carbon Dioxide Capture from Power Plants", OECD IEA

### 2.3.11 Pre-combustion: Membrane separation of H<sub>2</sub> from syngas

This section focuses on the potential for H<sub>2</sub> selective membranes in an integrated gasification combined cycle (IGCC) process. There are three main types of membrane materials selective for hydrogen over other gases such as CO<sub>2</sub>: metallic, porous inorganic and polymeric membranes.

#### *Metallic membranes*

Metallic membranes can produce hydrogen of up to 99.99% purity<sup>335</sup>. These are generally based on palladium, though it is possible to use a range of metals. In all cases, the process of hydrogen separation is achieved by the dissociative chemisorptions of hydrogen on the surface producing atomic hydrogen; this diffuses through the metal lattice driven by the partial pressure drop to the opposite side of the membrane. Here, atomic hydrogen is recombined into molecular hydrogen and diffuses away from the metallic surface. The rate of this process, and therefore permeability, is influenced by the metal surface roughness, purity and importantly the metallic lattice. The rate is also a function of temperature with palladium showing improved performance at higher temperatures<sup>335</sup>. This process makes metallic membranes almost 100% selective for H<sub>2</sub>, since no other gas will undergo dissociation upon the surface. Pd membranes have a number of problems, which reduce their attractiveness for large scale H<sub>2</sub> separation. Firstly, they can undergo phase changes at low temperature (<300°C), causing catastrophic failure due to hydrogen embrittlement. Efforts to develop body-centred-cubic (BCC)<sup>336</sup> alloy membranes suitable for industrial H<sub>2</sub> separation processes have increased recently and significant gains have been made in overcoming the inherent instability of these materials in hydrogen. Compared to competing face-centered-cubic alloys, BCC alloys have much higher solubilities that provide them with a high driving force for hydrogen permeation. This high solubility, however, exacerbates the problem of hydrogen embrittlement. Given their low cost components and high permeabilities, the development of membranes with sufficient durability and embrittlement resistance remains the greatest barrier to the widespread uptake of BCC membrane technology.

The presence of contaminants in the feed gas can also inhibit hydrogen dissociation and recombination reactions due to surface fouling. In particular, Pd is susceptible to sulphur compounds, CO, NH<sub>3</sub> and chlorine, all of which exist in pre-combustion syngas streams. For example, sulphur compounds destroy Pd membranes due to large lattice expansions when Pd-S is produced. Some of these issues have been overcome through the use of Pd alloys. For example the presence of Pt dramatically reduces the effect of sulphur degradation. However, the biggest issue for Pd membranes are their limited lifespan, of ten months, and the subsequent cost in replacing the membrane. Given that Pd is a precious metal, there are substantial operating costs associated with Pd-metallic membrane separation. Indeed, commercial application of these membranes has been limited to small volume processes<sup>335</sup>.

#### *Porous inorganic membranes*

Porous inorganic membranes have also been applied to the separation of hydrogen from carbon dioxide. A range of inorganic materials have been used, including silica, zeolites, alumina, nitrides, and oxides. These materials have carefully controlled pore structures and generally separate on the basis of molecular size; the smaller hydrogen molecule passes through while larger species are retained. Alternatively, if the pore sizes are larger, Knudsen diffusion can occur; in this case

separation is based on the difference in the mean path of gas molecules due to collisions with pore walls. Surface treatment to improve the sorption of H<sub>2</sub> to the pore walls can improve selectivity by increasing the migration rate of this species along the pore walls—this is known as surface diffusion.

The highest permeabilities are reported for hydrophobic silica based membranes<sup>335</sup>, though with relatively poor selectivities against CO<sub>2</sub>, dependent on fabrication technique. Also of benefit to silica systems are their low cost and their thermal and chemical stability, allowing them to be used with corrosive feeds and at high temperatures (conditions of up to 20 atm and 500°C can be tolerated). However, low H<sub>2</sub>/CO<sub>2</sub> selectivity is often observed. Exposure to high water vapour concentrations can also lead to performance decline.

#### *Non-porous polymeric membranes*

Non-porous polymeric membranes operate by the solution- diffusion mechanism. In this case the permeating gas dissolves into the polymer at one face of the membrane, diffuses across the membrane and then is desorbed at the downstream face. Permeability is thus a function of both gas diffusivity and solubility. The small size of the hydrogen molecule gives it a large diffusivity compared to other gases. However, the significantly lower critical temperature implies that condensability and therefore solubility of hydrogen within the polymeric membrane will be much lower. In H<sub>2</sub>-selective polymeric membranes, the high diffusivity is thus exploited while the effect of low solubility is limited. Such membranes are currently in application for H<sub>2</sub> recovery in the refining and chemical industry. Polymeric membranes can be provided as either intrinsically skinned hollow fibres or as asymmetric flatsheets. While it is generally much easier to provide an ultra-thin polymer skin layer in these arrangements, they are much less thermally stable with operating temperatures typically restricted to less than 100°C. In general, glassy polymeric membranes, which operate below the glass transition temperature, provide high H<sub>2</sub>/CO<sub>2</sub> selectivity due to a larger void fraction within the polymeric matrix. Hence, there is a wide range of polymeric membranes available for H<sub>2</sub> separation from CO<sub>2</sub>.

Importantly, polymeric membrane choice is strongly dependent on the ability of the membrane to maintain its separation performance in the process environment. In particular, exposure to condensing gases such as CO<sub>2</sub>, water and H<sub>2</sub>S can cause plasticization and subsequent mechanical failure. The extent of such plasticization is a function of the cohesiveness of the membrane structure and can be reduced by cross-linking of the membrane chains. Such cross-linking tends to concurrently increase selectivity but reduce permeability.

#### ***Development aspects and prospects***

##### ***Key drivers and issues for development***

The main technology advantages over IGCC acid gas removal are simplicity of the approach, the removal of gas through a selective film, ensuring high-energy efficiencies, small equipment foot print and therefore lower capital cost compared to conventional separation processes<sup>335</sup>. Gas separation membranes have been commercially proven in the sweetening of natural gas (removal of CO<sub>2</sub> and H<sub>2</sub>S) and are commonly used for H<sub>2</sub> recovery in refineries.

Metallic and porous inorganic membranes would appear to represent the most practical approach to a H<sub>2</sub>-selective membrane within an IGCC process. This is because they are able to undertake high temperature separation, while polymeric membranes, operating at low temperature, force a cooling

liability on the process. While Pd-based membranes offer the highest H<sub>2</sub> selectivity, the minor components present in syngas, especially sulphur, present a significant disadvantage. Porous inorganic membranes such as those based on silica or zeolites, are cheaper and offer greater chemical resilience. However, high water vapour loads can affect performance. The more recently developed thermally re-arranged polymeric membranes may yet offer a third viable alternative.

More generally, there are some doubts about the maximum scale achievable for membrane separation, due to the membrane surface area and reactor size. Other key issues include system stability, reducing the permeability of other gases, and operating temperatures. Current poor selectivity mean that remaining CO<sub>2</sub> will also contain CO, CH<sub>4</sub> and N<sub>2</sub> (needing additional purification), and the membrane will cause a pressure drop.

### ***Implications for retrofitting to existing plant***

As with all the other pre-combustion capture technologies, the retrofit of H<sub>2</sub> separation membranes to an existing IGCC plant is considered largely impractical, due to large modifications required in the gas flows paths and gas turbine specifications and operation.

### ***Technology Readiness Level, pilot plants***

To date, there are no clear winners amongst this group and none have been brought to commercial reality at large scale. More research is required into the development of such materials to bring them to a point where they can seriously challenge the more traditional solvent based approach. The current TRL is judged to be TRL 3, as the technology is at the lab scale, although pilot plants are beginning to be planned (by industry members such as Air Products). Developments are likely to continue, although initially on a limited sub-set of applications, hence the TRL could reach TRL 4 by 2020.

### ***Main players internationally, UK activities and capabilities***

H<sub>2</sub> membrane research is dominated by the US and Europe, with little UK activity. There are several European research institutions working in the area, however, no industry players have yet emerged with a commercial offering (although Praxair are beginning to get involved in the area).

### ***Technical and economic characteristics***

#### ***Equipment scales***

As the H<sub>2</sub> membrane is modular; it is likely to be suitable for small scales, although with a significant cost per kW<sub>e</sub>. Maximum reactor scales and membrane surface area are not yet known, as the technology costs will likely scale linearly. The scale of IGCC plants including H<sub>2</sub> separation is more likely to be determined by the economics of the IGCC power generation than the membrane.

#### ***Flexibility***

IGCC plants are complex to operate, have slow response times and have long start-up times from cold (~24hours). There are also large efficiency losses when operating at partial load. IGCC technology, with or without capture is not suitable for peak load operation. H<sub>2</sub> membrane separation is less complex than solvent absorption, hence adding capture has less impact on flexibility.

An alternative plant configuration under consideration for the future is to run the high-capex gasifier at full load, but then store the H<sub>2</sub> produced from the syngas. This buffer storage could then supply H<sub>2</sub> on demand for combustion in a much larger gas turbine combined cycle plant, i.e. highly flexible peaking power could be produced, with the gas turbine running at lower capacity factors than the gasifier.

Currently, with the gas turbine also requiring high purity N<sub>2</sub>, a separate buffer store for the N<sub>2</sub> produced from the ASU would also be required – however, in the future, gas turbine developments towards burning syngas in premix mode will negate the need for this nitrogen.

### ***CO<sub>2</sub> capture rate***

Current H<sub>2</sub> membranes have poor selectivity leading to CO<sub>2</sub> capture rates between 65% and 80% for a single membrane. Multiple stages are required for higher capture rates, but at added energy and capital cost. Rezyani et al.<sup>337</sup> assume a H<sub>2</sub> membrane system capture rate of 93%, or 2% higher than the IGCC with physical absorption capture they modelled.

### ***Economics and efficiencies***

Data in this area is very sparse. Rezyani et al.<sup>337</sup> gives similar capital costs using a Pd-Ag alloy membrane for hydrogen separation from syngas compared to pre-combustion with physical absorption. However, there is 1%-point efficiency gain for this technology over physical absorption, which results in slightly lower avoided CO<sub>2</sub> costs per kWh generated.

---

<sup>335</sup> Scholes C.A., Smith K.H., Kentish S.E., Stevens G.W., CO<sub>2</sub> capture from pre-combustion processes—Strategies for membrane gas separation, *International Journal of Greenhouse Gas Control* 4, 2010.

<sup>336</sup> Dolan M.D., Non-Pd BCC alloy membranes for industrial hydrogen separation, *Journal of Membrane Science* 362, 2010.

<sup>337</sup> Rezvani S., Huang Y., McIlveen-Wright D., Hewitt N., Deb Mondol J., Comparative assessment of coal fired IGCC systems with CO<sub>2</sub> capture using physical absorption, membrane reactors and chemical looping, *Fuel* 88, 2009

### 2.3.12 Pre-combustion: Sorbent enhanced reforming using carbonate looping

Carbonate looping CO<sub>2</sub> capture technology may be applied to pre-combustion CCS schemes whereby the CaO-based sorbent is used to affect the sorbent-enhanced reforming and water-gas shift reactions. That is, carbonate looping is directly integrated into the fuel conversion reaction scheme instead of removing the CO<sub>2</sub> from the exhaust of the coal or biomass-fired power station, which is the case for post-combustion applications.

Reforming and shift reactions underpin the gasification process whereby a fuel is reacted with insufficient O<sub>2</sub> for complete combustion (and typically in the presence of H<sub>2</sub>O) producing a mixture of combustible gases, including: CO, CH<sub>4</sub>, H<sub>2</sub> and H<sub>2</sub>O. The direct removal of the CO<sub>2</sub> from the reaction system as solid CaCO<sub>3</sub>, according to Equation 1, shifts the reforming reactions, e.g. Equations (2,3), and the water gas shift reaction, Equation (4), beyond thermodynamic equilibrium limitations, resulting in an increase in the output of H<sub>2</sub>. CaO has also been reported to catalyse the water-gas shift reaction<sup>338</sup> as well as catalysing tar cracking reactions<sup>339</sup>.

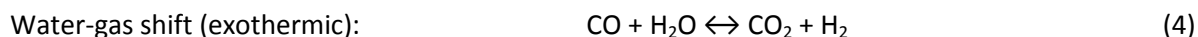
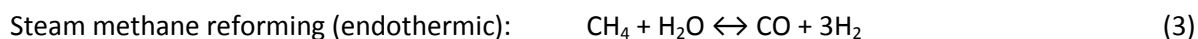
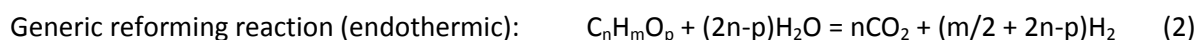

As described in detail in the context of post-combustion carbonate looping, the CaCO<sub>3</sub> can be subsequently decomposed in a separate oxy-fired calciner vessel to produce a pure stream of CO<sub>2</sub> by conducting the calcination (reverse of Equation 1) in an atmosphere of pure CO<sub>2</sub>. The basic effect is the removal of CO<sub>2</sub> from a gas stream where CO<sub>2</sub> is at a low concentration (i.e. a fuel gas) and the production of a concentrated stream of CO<sub>2</sub> suitable for storage. This CO<sub>2</sub> capture-and-release can be achieved by either temperature- or pressure-swing. Temperature swing requires significant heat input to the endothermic calciner, complicated by the requirement to provide heat without diluting the CO<sub>2</sub> gas. For this reason oxy-fired calciners are typically proposed. In a pressure-swing system, calcination can be carried out at a lower temperature than carbonation to exploit heat transfer from the exothermic carbonator to the endothermic calciner. This is achieved by elevating the carbonator pressure and running the calciner at atmospheric or sub-atmospheric pressure.

A number of process configurations have been proposed for directly integrating carbonate looping with fuel conversion technologies, shown in Figure 2.36 and Figure 2.37. These include: combined shift-carbonation<sup>340</sup>; sorbent enhanced reforming (SE-SMR)<sup>341,342</sup>; in situ CO<sub>2</sub> capture e.g., AER, LEGS and HyPr-RING<sup>339,343,344,345,346,347,348,349,350,351</sup>; and the zero-emission coal concepts (ZEC)<sup>352,353,354</sup>. These schemes are described in turn below.



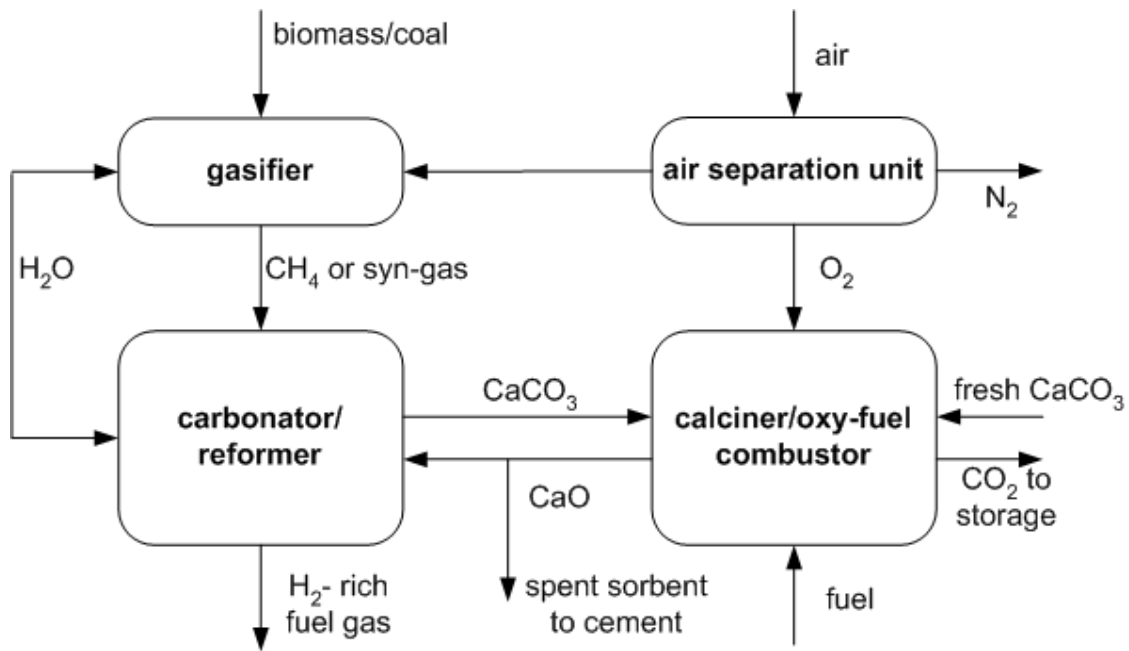

Figure 2.36: Carbonate looping for pre-combustion type power technology

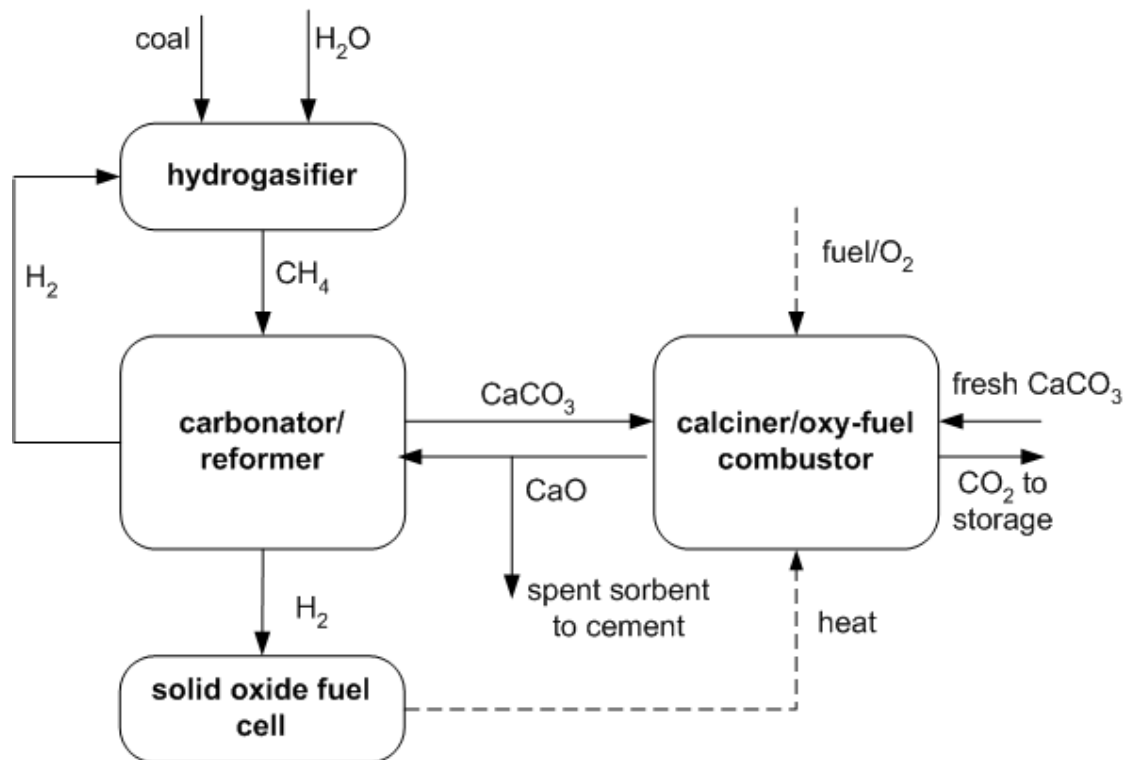

Figure 2.37: ZEC-type process with carbonate looping

A process coupling the carbonation reaction with the water-gas shift reaction for the production of  $H_2$  and the separation of  $CO_2$  was first patented in 1931. The patent describes the production of  $H_2$  by reacting equivalent quantities of steam and CO over a bed of CaO and some amount of MgO at temperatures between 300°C and 600°C and atmospheric pressure. Combining the shift and carbonation reactions represents a process simplification and improves efficiency by eliminating the

need for the input of an excessive quantity of steam. More recently, Han and Harrison<sup>340</sup> have published results from their study of the combined shift and carbonation reactions conducted in a laboratory-scale fixed bed reactor, reporting near complete equilibrium conversion of CO (> 0.995) and CO<sub>2</sub> capture at temperatures  $\geq 500^{\circ}\text{C}$  at 15 atm. Müller et al.<sup>338</sup> have investigated the cyclic stability of a variety of Ca-based sorbents for the combined carbonation and shift reactions using an atmospheric pressure fixed bed reactor. They reported superior performance using a synthetic sorbent derived from calcium magnesium acetate, compared to natural limestone and dolomite precursors (tested through five reaction-regeneration cycles).

Sorption-enhanced reforming (SER) of hydrocarbons to produce H<sub>2</sub> combines reforming, e.g., steam methane reforming (SMR) according to Equation (3) with the carbonation and the water-gas shift reactions in a single reaction step. This process, which is achieved using CaO mixed with a reforming catalyst (typically Ni-based) produces a concentrated stream of H<sub>2</sub> > 98 vol. % (dry basis)<sup>341,355</sup>. The reforming reaction is strongly endothermic, however when matched with the exothermic carbonation and water-gas shift reactions the overall process is thermally balanced. Thus, the potential energy savings of SER compared to standard SMR is reported to be in the order of 20%<sup>356</sup>. There is also the advantage of reducing the number of process steps by eliminating the shift reactors. However, some additional heat is required for calcination of CaCO<sub>3</sub> for sorbent regeneration. The SMR has been demonstrated experimentally at the lab-scale, for a range of temperatures and pressures using fixed-bed<sup>341</sup> and fluidised-bed reactors<sup>342</sup>.

A number of researchers have investigated the possibility of using the integrated reaction scheme for the gasification of solid fuels, including: the biomass Adsorption Enhanced Reforming process (AER)<sup>339,350</sup>, the Lime Enhanced Gasification Scheme (LEGS) using brown coal<sup>351</sup>, and the integrated coal gasification and H<sub>2</sub> production process, HyPr- RING<sup>346</sup>. These concepts eliminate the separate fuel gasification step shown in Figure 2.36 by combining gasification, reforming, shift and carbonation in a single reaction vessel.

The zero emission coal (ZEC) process is a hydrogen-gasification concept developed at Los Alamos National Laboratory (LANL). This scheme was first investigated by the Zero Emission Coal Alliance (ZECA) – a consortium of North American industry and government agency partners. The ZEC process, shown in Figure 2.37, first involves high-pressure gasification of coal in H<sub>2</sub> (hydro-gasification) to produce CH<sub>4</sub>, via the exothermic methanation reaction. The CH<sub>4</sub> is then reformed in a high-pressure reformer/carbonator (analogous to the SER process) to produce a H<sub>2</sub>-rich product gas. Overall, the reaction scheme results in the production of an additional 2 moles of H<sub>2</sub> for every 2 moles required for methanation. In the proposed process, some of the H<sub>2</sub> product gas is recycled to the gasifier and the remainder is used to produce electricity in a high-temperature solid oxide fuel cell (SOFC) with waste heat from the SOFC being used in a calciner to regenerate the CaO-based sorbent and produce a pure stream of CO<sub>2</sub>. Variants of the ZEC concept which eliminate the use of the high-temperature SOFC (to date unproven technology) include the ZECOMIX cycle which burns the H<sub>2</sub>-rich syngas in O<sub>2</sub> to raise steam and incorporates an oxy-fired calciner<sup>357, 358, 359</sup>. The incorporation of an oxy-fired calciner has also been proposed by Wang et al.<sup>360</sup>.

One of the major advantages of carbonate looping is the potential application to pre-combustion CCS power technologies as well as post-combustion capture schemes.

Suitable pre-combustion schemes include 'enhanced' hydrocarbon reforming, as well as H<sub>2</sub> enrichment of a synthesis gas produced by gasification of coal and/or biomass. The technology,

which is operable in temperature- and pressure-swing configurations, could potentially be integrated with IGCC coal gasification, NGCC and biomass gasification technologies.

To date, most experience at laboratory and small pilots scale (typically focussed on post-combustions applications) has used CFB and BFB reactors, suggesting a good potential for integration with BFB and CFB biomass conversion technologies, e.g., CaO-sorbent may be directly integrated as the reactor bed material. Fixed bed configurations, whereby the fuel gas inlet is 'switched' instead of cycling the solid CaO/CaCO<sub>3</sub>, have also been proposed and may be used for H<sub>2</sub> enrichment and CO<sub>2</sub> removal from fuel gas.

### ***Development aspects and prospects***

#### ***Technology Readiness Level***

A TRL of 1–2 is currently given to pre-combustion carbonate looping technologies (i.e., 1– Basic principles observed and reported; 2– Technology concept and/or application formulated). This technology readiness level assessment is made acknowledging that, although the idea of using CaO-based materials to capture CO<sub>2</sub> from a gas mixture dates back to more than a century ago, the use of carbonate looping for decarbonising electricity and/or H<sub>2</sub> production has only received significant research interest in the last 5–10 years<sup>361,362</sup>. Specifically, post-combustion 'temperature-swing' carbonate looping is considered the most developed application and was identified by The Technology Task Force of the European Technology Platform for Zero-Emission Power Plants as one of the highest priorities for future R&D<sup>363</sup>.

We also note that there is considerable cross-over in terms of key technical issues (discussed below) which means relevant insights can be gained from the research efforts focussing on post-combustion applications. (Post-combustion carbonate looping has been demonstrated in small pilot-scale rigs of the order of 100 KW<sub>th</sub> in laboratories in Canada, Spain and Germany and two projects are currently underway aiming to scale-up post-combustion calcium looping to 1 MW<sub>th</sub>, in Spain and Germany.)

A rapid advancement to a 2020 TRL of 4 or 5 "technology or part of technology validated in a working environment" may be expected by observing the trajectory for post-combustion carbonate looping (temperature-swing) which is becoming accepted as a CO<sub>2</sub> capture technology of considerable potential for full-scale demonstration. Given that post-combustion application has progressed from bench-scale (TRL: 1–2) to a planned demonstration at 1 MW<sub>th</sub> (TRL:4–5) in only ~10 years it is reasonable to assume that pilot-scale validation for pre-combustion carbonate looping systems could be achieved in a similar timeframe.

A key development feature which limits the risks associated with scale-up, applicable to pre- and post-combustion applications is the use of CFB technology. CFB is a mature technology in the power and industrial sectors and is considered to be the most suitable reactor for the carbonator and the calciner owing to very good gas-solid contacting and temperature uniformity across the reactor beds.

#### ***Drivers for development, key development issues***

The key driver for development is the potential to reduce the efficiency penalty associated with CO<sub>2</sub> capture and purification.

A technical issue relevant to all applications of carbonate looping technology is the drop-off in the capacity of CaO-sorbent derived from limestone to capture CO<sub>2</sub> through multiple capture-and-

release cycles. The loss in capacity necessitates the continuous input of large amounts of fresh limestone in order to maintain an acceptable CO<sub>2</sub> capture rate. Due to the low cost of the sorbent (crushed limestone), this does not represent a show-stopper but it does undermine the cost and energy efficiency of the process. The main factors influencing this drop-off in capacity are: sintering, attrition, and chemical deactivation due to the competing chemical reaction with sulphur dioxide (SO<sub>2</sub>). One option, for which the economics appear to be favourable is if there exists an opportunity for the exhausted sorbent to be used as a feedstock for cement manufacturing<sup>364,365,366</sup>.

Alternative methods under development for overcoming the drop-off in the capture capacity, include:

- Sorbent hydration<sup>367,368</sup>
- Doping with foreign ions<sup>369</sup>
- Thermal pre-treatments<sup>370</sup>
- Acetification<sup>371,372</sup>
- The use of inert porous supports<sup>373,374,375,376,377</sup>

To date, researchers have been successful in reducing the rate of decay, however, complete elimination of the drop-off has not been reported. An important driver for all of these methods is cost-effectiveness, because they must compete with cheap and abundant natural limestones and irreversible loss due to the presence of sulphur means some amount of fresh sorbent input may be unavoidable.

Engineering/operational issues that are relevant to the different proposed configurations (to varying extents) requiring further research and development are summarised:

- Solid circulation between two interconnected CFB or BFBs at industrially relevant scale for temperature swing operations
- Heat integration for efficient heat delivery to the calciner and heat removal from the carbonator applicable to temperature-swing operations
- Sorbent agglomeration and poisoning in the presence of solid fuels and/or ash under different reactive atmospheres (i.e.: air-fired, oxy-enriched and/or reducing environments) relevant to the use of solid fuel such as biomass in the calciner as well as more novel in situ CO<sub>2</sub> capture schemes
- Interaction between CaO and tar is expected to hamper CO<sub>2</sub> capture due to sorbent deactivation. However, the deactivation mechanism is not well understood. The elimination of tar from the product gas is a major technical challenge for biomass conversion processes. Elevating the reaction temperature (>800 °C) and the steam-to-biomass ratio are expected to increase the rate and extent of tar elimination by promoting the endothermic cracking and reforming of tar species. But, these elimination reactions lead to coke formation and the subsequent build up of coke on sorbent particles can effect sorbent deactivation. If it is assumed that deactivation of CaO is dependent on the concentration of the tar and subsequent deactivation due to coking then the tar concentration is likely to be critical for determining CaO loading. In addition CaO is well known to have a catalytic effect on the decomposition of tar species during biomass gasification whereby CaO or CaO-MgO may be used in situ or downstream from biomass gasifiers to effect tar elimination.

- Solid transport across pressure gradients (e.g., using lock-hoppers) relevant to pressure swing operations that may be important for integration with IGCC or NGCC technology
- Development of SOFCs capable of operating at high temperature for heat integration with the calciner according to the original ZEC concept. We note that given the immaturity of the capture technology it is likely that many of these issues may be circumvented or superseded subsequent to more detailed engineering design, e.g. as discussed above, the incorporation of an oxy-fired calciner to eliminate the need for a high-temperature SOFC has been proposed.

### ***Environmental factors***

Key issues regarding health and safety/environmental emissions include the presence of large quantities of CaO, which forms a highly caustic aqueous solution and the reaction between CaO and H<sub>2</sub>O is highly exothermic. As well, many of the proposed configurations incorporate an air separation unit for producing O<sub>2</sub> and produce a H<sub>2</sub>-rich fuel gas. Potential health and safety risks are mitigated by adopting protocols developed in industries (e.g., cement, oil and gas) where such risks are routinely managed.

### ***Pilot and demonstration plants***

A number of researchers have demonstrated key elements of pre-combustion carbonate looping technology (e.g. H<sub>2</sub> enrichment of fuels gas) at industrially relevant scales; however, in general, the production of a pure stream of CO<sub>2</sub> suitable for storage has not been a research and development priority.

The first example is the CO<sub>2</sub> Acceptor Process which dates back to the 1960s (continuing to the 1980s) by Consolidation Coal Company. Pilot plant trials were carried out in South Dakota, USA<sup>378</sup> using a facility consisting of two interconnected BFBs. One BFB was operated as pressurised gasifier/carbonator under steam (~ 10 atm and 825°C); and the second as a combustor/calciner (1000°C). Unfortunately there is very limited publicly available data from these trials.

The Adsorption Enhanced Reforming (AER) process is a steam gasification process which uses biomass fuels (funded under the European Commission 6<sup>th</sup> Framework Programme). Initial pilot plant investigations were carried out at the Vienna University of Technology, Austria, using their Fast Internally Circulating Fluidized Bed (FICFB) technology at a scale of 120 kW<sub>th</sub> (fuel input). The reactor system has a gasifier/carbonator reaction zone operating at 600–700 °C and atmospheric pressure and an air-fired combustor/calciner zone<sup>339</sup>. Hot CaO is cycled from the combustor/calciner zone to deliver heat for the endothermic steam gasification reaction and char and CaCO<sub>3</sub> is circulated to the combustor/calciner. This process produces a H<sub>2</sub>-rich fuel gas (~ 70 %-vol) and a flue gas, but does not result in the production of pure CO<sub>2</sub>; however, if oxygen was used in the combustor/calciner then a pure stream of CO<sub>2</sub> could be produced<sup>350</sup>. Larger trials have been conducted at the scale of 8 MW<sub>th</sub> (fuel input) at the Guessing CHP plant, Austria which has been in operation since 2002<sup>349</sup>. Wood chips were used as fuel and the bed material was a mixture of natural olivine and limestone.

CANMET Energy and Technology Centre, Ottawa (Natural Resources Canada) have a 75 kW<sub>th</sub> dual fluidised bed pilot plant consisting of a CFB calciner and a BFB combustor/carbonator<sup>379</sup>. The calciner can be operated as an oxy-fired combustor with flue gas recycle suitable for producing a pure stream of CO<sub>2</sub>. A recent paper published by Lu et al.<sup>380</sup> describes 50 hours of continuous operation under different calciner operating modes including oxy-fired combustion with biomass (low-ash wood

pellets) and bituminous coal (high-volatile, medium-sulphur bituminous). This facility has also been used (in batch mode) to investigate CO<sub>2</sub> capture from a simulated syn-gas<sup>381</sup>.

The Spanish Government Coal Research Centre, INCAR have two interconnected 30 kW<sub>th</sub> CFBs which have been used to investigate biomass combustion with in situ CO<sub>2</sub> capture using CaO<sup>382</sup>. The biomass fuels tested to date include saw dust, saw dust pellets and olive pips. In this investigation the calciner was air-fired so a pure stream of CO<sub>2</sub> was not produced. Although these test results are not directly applicable to enhanced shift/reforming they do demonstrate the potential of the concept of in situ CO<sub>2</sub> capture using biomass feedstock relevant to many of the proposed configurations.

### ***Main player internationally, UK activities and capabilities***

Academic research conducted in the UK has been carried out at Imperial College, University of Cambridge, University of Leeds and Cranfield University. To date, all of the research conducted has been at the bench-scale with a significant focus on CaO-sorbent characterisation and reactivity enhancement.

Imperial College is also part of the EU CaOling project consortium which is focussed on scaling up post-combustion carbonate looping. Other academic members of the consortium include: INCAR (Spain Research Council), Lappeenranta University of Technology (Finland), Institute of Combustion and Power Plant Technology, University of Stuttgart (Germany), and the University of Ottawa. Non-academic members of the CaOling consortium which are funding research in carbonate looping, include: Endesa Generacion S.A (Spain), Foster Wheeler Energia (Spain), Hunosa Group (Spain). In addition, Cemex (UK, Mexico, USA and Europe) also is interested in carbonate looping for mitigating emissions in the cement industry.

### ***Technical and economic characteristics***

Given the low TRL (1–2) for the pre-combustion carbonate looping technologies, there is very limited data available for determining technical and economic characteristics, including estimated capital costs.

### ***Ease of retrofitting***

Because the technologies are heavily integrated with the fuel conversion reaction scheme, only new build applications are considered possible (i.e. it is assumed that the technology is unlikely to be adopted for retrofit applications).

### ***Equipment scales, flexibility***

With regards to plant scale, it is reasonable to assume that scale will be limited by biomass feedstock availability and economics, not technical constraints associated with the capture plant design operation. The primary feedstock for pre-combustion carbonate looping is natural limestone which is cheap and abundant. It is assumed that the operating flexibility of the pre-combustion CCS facilities using biomass and/or coal is likely to be limited by the high capital cost of the gasification equipment and thus need to run at full load; however, the ability to produce electricity and H<sub>2</sub> allow for the possibility of gas storage, such that operations may continue during periods of low electricity demand.

### **CO<sub>2</sub> capture rate**

Capture rates above 90 % are technically feasible, dependent on the assumed regeneration cycle, i.e. temperature-swing, direct or indirect heating or pressure-swing.

### **Efficiencies**

The major driver for research and development of pre-combustion carbonate looping is the potential for a reduction in the parasitic energy demand. A wide range of estimates of the theoretical thermal efficiencies of pre-combustion carbonate looping schemes are reported in the literature<sup>352,353,358,359,357,360,351,383,384</sup>. For the ZEC concept, the Nexant and ZECA study estimated the overall efficiency to be about 68.9%, including CO<sub>2</sub> compression<sup>352</sup>, however a more recent analysis considering sorbent decay estimated a considerably lower efficiency of about 40%<sup>353</sup>. Variants of the original ZEC concept which eliminate the use of the high-temperature SOFC are estimated to have efficiency from about 50–60%<sup>358,360</sup>. The estimated efficiency of the LEGS process which gasifies brown coal in a dual fluidized bed system (in situ CO<sub>2</sub> capture) was 48% (LHV), with about 6 %-points deducted for O<sub>2</sub> production and CO<sub>2</sub> compression. Two studies estimate the efficiency of the SE-SMR integrated with a combined cycle plant to be about 50.5 % compared to the assumed efficiency of a NGCC plant without capture of 58.6%<sup>383,384</sup>.

### **Economics**

Closely correlated with the overall process efficiency is the cost efficiency for power plants with CO<sub>2</sub> capture. However, of all the studies reviewed, only one study includes an economic assessment in their analysis, namely Nexant<sup>352</sup>. In the case of pre-combustion systems like the ZEC concept, where the CO<sub>2</sub> capture is integrated with the fuel conversion, it is not possible to compare costs of CO<sub>2</sub> avoided for plants with and without CO<sub>2</sub> capture; hence the appropriate base case is a reference power plant including the CO<sub>2</sub> capture system. Accordingly, the Nexant and ZECA report compare the cost of electricity for the 600 MW<sub>e</sub> ZEC plant with data published by DeLallo et al.<sup>385</sup> for a range of gasification technologies with CO<sub>2</sub> capture – selected data is presented in Table 2.19. (The data presented was adjusted to an availability of 90 % capacity and a 12% cost of money and 20 year investment term was used in the economic assessment<sup>352</sup>)

One paper published by Mackenzie et al.<sup>386</sup> provides a comprehensive assessment of the economics of post-combustion carbonate looping, integrated with a pressurised CFB combustor in Western Canada. Key elements of the capture technology are common to pre-combustion carbonate looping systems, e.g., limestone receiving, storing and handling facilities, the carbonator and calciner modules and O<sub>2</sub> plant. They estimated the cost of electricity to be ¢ 6.471 / kWh (Canadian, 2005) with a contribution to the total cost for the capture equipment of ¢ 1.186 / kWh, i.e., approximately 20% of the total cost of electricity.

**Table 2.19: Comparison of selected power technologies with CO<sub>2</sub> capture from the Nexant and ZECA report<sup>352,385</sup>**

	ZEC	F Class GTCC	H Class GTCC	IGCC with H Class GT
Efficiency, HHV (%)	68.9	39.2	43.3	37.0
Cost of electricity ¢/kWh	4.32	4.59	4.25	4.47

### **Feedstocks and feasibility**

Direct contact between the sorbent particles and the biomass fuel in the gasifier/carbonator (e.g. for the AER process<sup>339</sup>) may result in sorbent deactivation due to coking or ash fouling. However, further work is required to establish workable limits and fuels may need to be tested on a case-by-case basis, e.g., fuel-bound elements such as K, Na may lead to increased rates of sintering. Similar issues are expected with direct firing of fuel in the combustor/calcliner as demonstrated by Abanades et al<sup>387</sup>.

The interaction between CaO and tar, which is expected to hamper CO<sub>2</sub> capture due to sorbent deactivation, was discussed in detail above.

Also discussed, CaO will react with sulphur (SO<sub>2</sub>), reducing the amount of sorbent available to capture CO<sub>2</sub><sup>365</sup>. This is not considered a major issue because of the typically low sulphur content of biomass feedstocks.

- 
- <sup>338</sup> Muller, C.R., et al., Investigation of the Enhanced Water Gas Shift Reaction Using Natural and Synthetic Sorbents for the Capture of CO<sub>2</sub>. *Industrial & Engineering Chemistry Research*, 2009.
- <sup>339</sup> Pfeifer, C., B. Puchner, and H. Hofbauer, Comparison of dual fluidized bed steam gasification of biomass with and without selective transport of CO<sub>2</sub>. *Chemical Engineering Science*, 2009. **64**(23): p. 5073-5083
- <sup>340</sup> Han, C. and D.P. Harrison, Simultaneous shift reaction and carbon dioxide separation for the direct production of hydrogen. *Chemical Engineering Science*, 1994. **49**(24, Part 2): p. 5875-5883
- <sup>341</sup> Balasubramanian, B., et al., Hydrogen from methane in a single-step process. *Chemical Engineering Science*, 1999. **54**(15-16): p. 3543-3552
- <sup>342</sup> Johnsen, K., et al., Sorption-enhanced steam reforming of methane in a fluidized bed reactor with dolomite as CO<sub>2</sub>-acceptor. *Chemical Engineering Science*, 2006. **61**(4): p. 1195-1202.
- <sup>343</sup> Lin, S., et al., Hydrogen production from coal by separating carbon dioxide during gasification. *Fuel*, 2002. **81**(16): p. 2079-2085
- <sup>344</sup> Lin, S., et al., Continuous experiment regarding hydrogen production by coal/CaO reaction with steam (I) gas products. *Fuel*, 2004. **83**(7-8): p. 869-874
- <sup>345</sup> Lin, S., et al., Process analysis for hydrogen production by reaction integrated novel gasification (HyPr-RING). *Energy Conversion and Management*, 2005. **46**(6): p. 869-880
- <sup>346</sup> Lin, S., et al., Continuous experiment regarding hydrogen production by Coal/CaO reaction with steam (II) solid formation. *Fuel*, 2006. **85**(7-8): p. 1143-1150.
- <sup>347</sup> Lin, S., Y. Wang, and Y. Suzuki, High-Temperature CaO Hydration/Ca(OH)<sub>2</sub> Decomposition over a Multitude of Cycles. *Energy & Fuels*. **0**(0)
- <sup>348</sup> Lin, S.-Y., et al., Developing an innovative method, HyPr-RING, to produce hydrogen from hydrocarbons. *Energy Conversion and Management*. **43**(9-12): p. 1283-1290
- <sup>349</sup> Koppatz, S., et al., H<sub>2</sub> rich product gas by steam gasification of biomass with in situ CO<sub>2</sub> absorption in a dual fluidized bed system of 8 MW fuel input. *Fuel Processing Technology*, 2009. **90**(7-8): p. 914-921
- <sup>350</sup> Pröll, T. and H. Hofbauer, H<sub>2</sub> rich syngas by selective CO<sub>2</sub> removal from biomass gasification in a dual fluidized bed system -- Process modelling approach. *Fuel Processing Technology*, 2008. **89**(11): p. 1207-1217
- <sup>351</sup> Weimer, T., et al., Lime enhanced gasification of solid fuels: Examination of a process for simultaneous hydrogen production and CO<sub>2</sub> capture. *Fuel*, 2008. **87**(8-9): p. 1678-1686
- <sup>352</sup> Nexant, I., Zero Emission Coal Alliance Project Conceptual Design and Economics. 2000
- <sup>353</sup> Perdikaris, N., et al., Design and optimization of carbon-free power generation based on coal hydrogasification integrated with SOFC. *Fuel*, 2009. **88**(8): p. 1365-1375
- <sup>354</sup> Gao, L., et al., Zero-emission carbon concept (ZECA): Equipment commissioning and extents of the reaction with hydrogen and steam. *Energy & Fuels*, 2008. **22**(1): p. 463-470
- <sup>355</sup> Harrison, D.P., Sorption-Enhanced Hydrogen Production: A Review. *Industrial & Engineering Chemistry Research*, 2008. **47**(17): p. 6486-6501
- <sup>356</sup> Lopez Ortiz, A. and D.P. Harrison, Hydrogen Production Using Sorption-Enhanced Reaction. *Industrial & Engineering Chemistry Research*, 2001. **40**(23): p. 5102-5109
- <sup>357</sup> Galeno, G. and G. Spazzafumo, ZECOMIX: Performance of alternative lay-outs. *International Journal of Hydrogen Energy*. **35**(18): p. 9845-9850
- <sup>358</sup> Romano, M. and G. Lozza, Zecomix: A zero-emissions coal power plant, based on hydro-gasification, CO<sub>2</sub> capture by calcium looping and semi-closed high temperature steam cycle. *Energy Procedia*, 2009. **1**(1): p. 1473-1480



- <sup>359</sup> Romano, M.C. and G.G. Lozza, Long-term coal gasification-based power plants with near-zero emissions. Part A: Zecomix cycle. *International Journal of Greenhouse Gas Control*. **4**(3): p. 459-468.
- <sup>360</sup> Wang, J., E.J. Anthony, and J.C. Abanades, Clean and efficient use of petroleum coke for combustion and power generation. *Fuel*, 2004. **83**(10): p. 1341-1348
- <sup>361</sup> Shimizu, T., et al., A twin fluid-bed reactor for removal of CO<sub>2</sub> from combustion processes. *Chemical Engineering Research & Design*, 1999. **77**(A1): p. 62-68
- <sup>362</sup> Silaban, A. and D.P. Harrison, High temperature capture of carbon dioxide: Characteristics of the reversible reaction between CaO(s) and CO<sub>2</sub>(g). *Chemical Engineering Communications*, 1995. **137**: p. 177-190
- <sup>363</sup> EUTTF, The EU Technology Platform for Zero Emission Fossil Fuel Power Plants, Recommendations for RTD, support actions and international collaboration activities within FP7 Energy Work programmes in support of deployment of CCS in Europe, 18 April 2008, available at <http://www.zero-emissionplatform.eu/website/docs/ETP%20ZEP/TEch%20Input%20FP7%203rd%20call%20080418.pdf>. 2008
- <sup>364</sup> Dean, C.C., et al., The calcium looping cycle for CO<sub>2</sub> capture from power generation, cement manufacture and hydrogen production. *Chemical Engineering Research and Design*. **In Press, Corrected Proof**.
- <sup>365</sup> Blamey, J., et al., The calcium looping cycle for large-scale CO<sub>2</sub> capture. *PROG ENERG COMBUST*, 2010. **36**(2): p. 260-279.
- <sup>366</sup> Dean, C.C., D. Dugwell, and P.S. Fennell, Investigation into potential synergy between power generation, cement manufacture and CO<sub>2</sub> abatement using the calcium looping cycle. *Energy & Environmental Science*, 2011
- <sup>367</sup> Manovic, V., D. Lu, and E.J. Anthony, Steam hydration of sorbents from a dual fluidized bed CO<sub>2</sub> looping cycle reactor. *Fuel*, 2008. **87**(15-16): p. 3344-3352
- <sup>368</sup> Blamey, J., et al., Reactivation of a CaO-based sorbent for CO<sub>2</sub> capture from stationary sources. *Proceedings of the Combustion Institute*. **33**(2): p. 2673-2681
- <sup>369</sup> Lu, H. and P.G. Smirniotis, Calcium Oxide Doped Sorbents for CO<sub>2</sub> Uptake in the Presence of SO<sub>2</sub> at High Temperatures. *Industrial & Engineering Chemistry Research*. **0**(0).
- <sup>370</sup> Manovic, V., E.J. Anthony, and D. Loncarevic, CO<sub>2</sub> looping cycles with CaO-based sorbent pretreated in CO<sub>2</sub> at high temperature. *Chemical Engineering Science*, 2009. **64**(14): p. 3236-3245
- <sup>371</sup> Li, F., L. Zeng, and L.-S. Fan, Techno-Economic Analysis of Coal-Based Hydrogen and Electricity Cogeneration Processes with CO<sub>2</sub> Capture. *Industrial & Engineering Chemistry Research*: p. null-null.
- <sup>372</sup> Li, Y., et al., Modified CaO-based sorbent looping cycle for CO<sub>2</sub> mitigation. *Fuel*, 2009. **88**(4): p. 697-704
- <sup>373</sup> Li, Z.-s., N.-s. Cai, and Y.-y. Huang, Effect of Preparation Temperature on Cyclic CO<sub>2</sub> Capture and Multiple Carbonation/Calcination Cycles for a New Ca-Based CO<sub>2</sub> Sorbent. *Industrial & Engineering Chemistry Research*, 2006. **45**(6): p. 1911-1917
- <sup>374</sup> Li, Z.-s., et al., Synthesis, Experimental Studies, and Analysis of a New Calcium-Based Carbon Dioxide Absorbent. *Energy & Fuels*, 2005. **19**(4): p. 1447-1452
- <sup>375</sup> Manovic, V. and E.J. Anthony, CO<sub>2</sub> Carrying Behavior of Calcium Aluminate Pellets under High-Temperature/High-CO<sub>2</sub> Concentration Calcination Conditions. *Industrial & Engineering Chemistry Research*. **49**(15): p. 6916-6922
- <sup>376</sup> Dennis, J.S. and R. Pacciani, The rate and extent of uptake of CO<sub>2</sub> by a synthetic, CaO-containing sorbent. *Chemical Engineering Science*, 2009. **64**(9): p. 2147-2157
- <sup>377</sup> Florin, N.H., J. Blamey, and P.S. Fennell, Synthetic CaO-Based Sorbent for CO<sub>2</sub> Capture from Large-Point Sources. *Energy & Fuels*. **24**(8): p. 4598-4604
- <sup>378</sup> Curran, G.P., Fink, C.E., Gorin, E., Carbon dioxide-acceptor [coal] gasification process. *Studies of acceptor properties. Advances in chemistry series 1967*. **69**: p. 141
- <sup>379</sup> Hughes, R.W., et al., Design, process simulation and construction of an atmospheric dual fluidized bed combustion system for in situ CO<sub>2</sub> capture using high-temperature sorbents. *Fuel Processing Technology*, 2005. **86**(14-15): p. 1523-1531
- <sup>380</sup> Lu, D.Y., R.W. Hughes, and E.J. Anthony, Ca-based sorbent looping combustion for CO<sub>2</sub> capture in pilot-scale dual fluidized beds. *Fuel Processing Technology*, 2008. **89**(12): p. 1386-1395
- <sup>381</sup> Symonds, R.T., et al., CO<sub>2</sub> Capture from Simulated Syngas via Cyclic Carbonation/Calcination for a Naturally Occurring Limestone: Pilot-Plant Testing. *Industrial & Engineering Chemistry Research*, 2009. **48**(18): p. 8431-8440
- <sup>382</sup> Abanades, J.C., M. Alonso, and N. Rodriguez, Experimental validation of in situ CO<sub>2</sub> capture with CaO during the low temperature combustion of biomass in a fluidized bed reactor. *International Journal of Greenhouse Gas Control*, 2010. **In Press, Corrected Proof**
- <sup>383</sup> Romano, M.C., et al., Application of the Sorption Enhanced-Steam Reforming process in combined cycle-based power plants. *Energy Procedia*. **4**: p. 1125-1132
- <sup>384</sup> Solieman, A.A.A., et al., Calcium oxide for CO<sub>2</sub> capture: Operational window and efficiency penalty in sorption-enhanced steam methane reforming. *International Journal of Greenhouse Gas Control*, 2009. **3**(4): p. 393-400
- <sup>385</sup> DaLallo, M.R., et al., Evaluation of innovative fossil cycles incorporating CO<sub>2</sub> removal, in 2000 Gasification Technologies Conference. 2000
- <sup>386</sup> MacKenzie, A., et al., Economics of CO<sub>2</sub> Capture using the Calcium Cycle with a Pressurized Fluidized Bed Combustor. *Energy Fuels*, 2007. **21**: p. 920
- <sup>387</sup> Abanades, J.C., M. Alonso, and N. Rodriguez, Experimental validation of in situ CO<sub>2</sub> capture with CaO during the low temperature combustion of biomass in a fluidized bed reactor. *International Journal of Greenhouse Gas Control*. **In Press, Corrected Proof**.

## 2.4 Feedstocks and pre-processing considerations

The majority of the biomass materials currently utilised as fuels are waste and residue materials from forestry, agriculture and other activities. In most cases, these materials were traditionally left in situ in the forest or field, or were sent to landfill for disposal. In recent years, however, their value as a renewable fuel has been recognised, and they are being collected, processed if necessary, and delivered as fuels for utilisation in combustion and other thermal processing plants.

This significant increase in the industrial utilisation of these materials for heat and power production has been in response to commitments to reduce greenhouse gas emissions, along with the financial and other instruments that have been put in place to encourage renewable energy use. In the future, the utilisation of energy crops specifically cultivated and harvested for fuel applications are also projected to form a significant part of our biomass resources.

This section of the report aims out to:

- Identify the solid biomass feedstocks that are most likely to be utilised as feedstocks for biomass CCS plants, now and in the future
- To describe the physical forms, fuel properties and ash behaviour of the different biomass feedstock materials
- Introduce and describe the benefits and costs of the different pre-processing options
- Assess the likely impact and suitability of each feedstock on the performance and integrity of each biomass conversion technology, and if any pre-processing is required

### 2.4.1 Feedstock availability

The following biomass feedstocks have been considered in this study:

- Forestry (both UK and global): timber, short roundwood, forestry residues, arboricultural arisings
- Waste wood (UK): sawdust, chip board, MDF
- Woody energy crops (both UK and global): willow, poplar, eucalyptus
- Energy grasses (both UK and global): miscanthus, switchgrass, reed canary grass
- Agricultural residues (UK only): wheat, barley and oil seed rape straws
- Other imported feedstocks (global only): olive, palm and sunflower residues, along with bagasse

However, some of these feedstocks are more commonly used than others in the UK power sector today, and this picture will be likely to change by 2050. In order to give an indication of which feedstocks are the most important for consideration in this TESBIC project, we are using current consumption data from Ofgem (for the year 2009/2010)<sup>388</sup>, as well as future resource estimates from E4tech's work for DfT<sup>389</sup>.

Table 2.20 shows that UK forestry is currently the most commonly used biomass feedstock in the UK power sector, with some UK straw and imported residues also being used. This overall value of 56.7 PJ/yr consumption also agrees with the modelling in DECC's 2050 Pathways Analysis<sup>390</sup>, which gives a power sector consumption of 52 PJ/yr solid biomass in 2010.

Table 2.21 shows that even in two very different views of future global development (IEA Reference and Blue Map), total resource availability increases significantly to 2030. Imported woody energy crops & energy grasses are projected to become the dominant feedstocks by 2030 – hence likely to be a significant part of the UK power sector’s consumption. Note that the figures in Table 2.21 are potential supply estimates for the whole of the UK, and not predicted UK power sector demand. Not all of this potential supply may be used, and the figures also do not consider any UK competing demands for solid biomass in heat, industry or biofuels sectors, since future market prices and policy are likely to determine which sectors, including power, are able to access which resources.

**Table 2.20: Current annual consumption of solid biomass by the UK power sector<sup>388</sup>**

PJ/yr	2009/2010
UK forestry	32.5
UK woody energy crops	0.5
UK energy grasses	0.1
UK straw	6.2
UK waste wood	3.7
Imported forestry	3.2
Imported energy crops & grasses	-
Imported residues	10.5
<b>TOTAL</b>	<b>56.7</b>

**Table 2.21: Potential supplies of solid biomass available to the UK, before any UK demands considered<sup>407</sup>**

PJ/yr	IEA Reference			IEA Blue Map		
	2020	2030	2050	2020	2030	2050
UK forestry	35	46	65	79	86	110
UK woody energy crops	6	32	46	9	75	181
UK energy grasses	6	32	46	9	75	181
UK straw	71	77	77	83	83	83
UK waste wood	80	78	78	80	78	78
Imported forestry	31	15	5	32	3	-
Imported energy crops & grasses	169	425	388	651	3,213	2,462
Imported residues	21	12	2	99	78	-
<b>TOTAL</b>	<b>419</b>	<b>718</b>	<b>708</b>	<b>1,042</b>	<b>3,692</b>	<b>3,094</b>

#### 2.4.2 Biomass sustainability and international trade

Although biomass is a plentiful and commercially proven source of renewable energy worldwide, its carbon neutrality and sustainability is often the subject of some debate. While it is accepted that the combustion of biomass emits only the same quantity of CO<sub>2</sub> as is captured by its growth, a more comprehensive analysis is still required to properly address carbon emissions over the whole production, supply and utilisation lifecycle. This includes the use of fossil fuels and other materials during the cultivation, harvesting, processing and transportation of the biomass. There are also

significant land use issues, biodiversity and environmental issues and concerns about the impact of large scale biomass fuel production on local communities.

Significant efforts are being made to ensure that only sustainable biomass is used in power generation in the UK and elsewhere and, whilst it is anticipated that the application of strict sustainability criteria may restrict the amount of biomass which is globally available, this is not anticipated to have a major impact upon the ability of the UK power sector to source the necessary material.

Large-scale use of biomass in the UK will inevitably mean the use of substantial amounts of imported material. This means that extensive supply chains will have to be set up to service the large biomass demands from the UK power sectors and other industries. One key component of many of these supply chains will be the bulk marine transportation of biomass in a relatively dry and densified form, most likely as pelletised material. When calculating overall CO<sub>2</sub> lifecycle emissions, the additional costs, energy and other inputs associated with the drying, milling and pellet-production process are usually more than offset by the reduced transportation and handling costs. In future, it is possible that the utilisation of torrefied pellets may become significantly more popular, as an alternative to standard biomass pellets in this context, as torrefied pellets can offer further energy, cost and CO<sub>2</sub> savings across the supply chain.

It has to be recognised that the global biomass industry is at an early stage of development, with the total international market in biomass fuels involving only a few million tonnes per annum. The necessary investments in large scale production, pelletising, torrefaction and transport facilities are only just starting to occur. It is assumed that, by 2050 or earlier, the global industry will have matured to the point where sustainable biomass is traded as a commodity and can be relied upon as a secure source of renewable energy for the UK.

### **2.4.3 Physical and fuel properties**

The most important biomass physical forms are presented in Table 2.22. These include pellets, briquettes, dusts, chips, logs, and bales. A number of these materials have been standardised and have a well-defined size, shape and set of physical properties.

The fuel properties of different biomass materials can vary widely. Some fairly typical data for a number of different types of biomass, covering the proximate and ultimate analysis data, and the heating values, are listed in Table 2.23. These data are all presented on a dry basis, to enable a comparison between feedstocks with different moisture contents. It should be noted that the moisture contents of woody biomass materials can vary widely from 50-60% for raw green wood materials, 15-25% for straws and energy grasses (depending on the time of harvest), down to values less than 10% for dried and pelletised products.

The energy content of biomass decreases linearly with increasing moisture content, hence the transport and storage of wetter biomass is less efficient. Storage of high moisture content biomass also has other issues such as a greater risk of composting, causing loss of biomass and potentially a fire risk from elevated temperatures and mould formation – but good ventilation and air flow help to minimise these problems<sup>391</sup>.

The delivered feedstock moisture content can also have a significant impact on overall power plant efficiencies. Moisture within the feedstock has to be evaporated before the first stages of

combustion or gasification can occur, and this conversion of water into steam requires heat energy input. This reduces the overall system efficiency and potentially reduces combustion or gasification temperatures below the optimum plant design levels. In addition to the generally much larger scales of coal power plants, these lower calorific values for biomass compared to coal are main reason why dedicated biomass plants have lower efficiencies than coal plants.

Lower operating temperatures will tend to lead to less complete carbon conversion, and the increased generation of tars. For this reason, many combustion boilers and gasifiers are only able to take a specified range of low moisture content biomass. However, there are other systems designed specifically to take wetter or more variable feedstocks, with the use of integrated drying occurring prior to the main fuel reaction. The future analysis in Work Package 2 will define the feedstocks properties and moisture contents being considered.

The volatile matter content of the woody biomass materials, on a dry basis, are very high, of the order of 75-85%, depending on the ash content amongst other things. The ash content for woody biomass varies between 0.1 - 8%, depending on the quantity of bark and of tramp material. The ash content of green white wood material is generally very low, less than 0.5%. The ash content of bark tends to be significantly higher, commonly up to around 5% or so, depending on the species.

Some biomass materials have higher inherent ash levels and can be contaminated with sand, solids and other tramp materials, and this can have the effect of increasing the ash content of the delivered fuel significantly.

**Table 2.22: Major traded forms of solid biomass<sup>392</sup>**

<b>Fuel Name</b>	<b>Typical Particle size</b>	<b>Common Preparation Method</b>
Briquettes	∅ > 25 mm	Mechanical Compression
Pellets	∅ < 25 mm	Mechanical Compression
Fuel Powder	< 1 mm	Milling
Sawdust	1mm – 5 mm	Cutting with sharp tools
Wood chips	5mm – 100 mm	Cutting with sharp tools
Hog fuel	Varying	Crushing with blunt tools
Logs	100 mm – 1000 mm	Cutting with sharp tools
Whole wood	> 500 mm	Cutting with sharp tools
Small straw bales	0.1 m <sup>3</sup>	Compressed and bound to cubes
Big straw bales	3.7 m <sup>3</sup>	Compressed and bound to cubes
Round straw bales	2.1 m <sup>3</sup>	Compressed and bound to cylinders
Bundle	Varying	Lengthways oriented and bound
Bark	Varying	Debarking residue from trees Can be shredded or unshredded
Chopped straw	10mm to 200 mm	Chopped during harvesting
Grain or seed	Varying	No preparation or drying
Shells and fruit stones	5mm to 15 mm	No preparation
Fibre cake	Varying	Dewatering from fibrous waste

The carbon, hydrogen and oxygen contents of the clean, woody biomass materials on a dry basis are generally in the ranges 50-53%, 6.0-6.2% and 40-42% respectively. The nitrogen, sulphur and chlorine contents are very low, typically <0.6%, <0.1% and <0.05% respectively. Fluorine contents are rarely measured, but usually negligible. Again, the nitrogen content of clean white wood material is normally very low, of the order of 0.1-0.2% or so. The nitrogen content of the bark tends to be significantly higher, and the nitrogen content of woody biomass materials generally increase with increasing bark content. The Gross Calorific Values of the large majority of woody biomass materials

are in the range 19.5-21.5 MJ kg<sup>-1</sup>, on a dry basis, depending on the species, the bark content and the ash content of the fuel.

Similar fuel analysis data for a number of grasses, straws and residues which are of interest as boiler fuels are shown in Table 2.23. In general terms, these materials are faster growing than the woody biomass materials, and sometimes have been grown with the application of mineral fertilisers. The straws and residues commonly have higher ash contents, and higher nitrogen, sulphur and chlorine contents than the wood based biomass materials, and the calorific values are correspondingly lower.

**Table 2.23: Typical proximate and ultimate analyses, and calorific values**

Feedstock category	Feedstock	Ref	Proximate analysis (% dry fuel)			Ultimate analysis (% dry fuel)						Calorific Value (MJ/kg)
			Fixed carbon	Volatile matter	Ash	C	H	O (diff.)	N	S	Cl	
Forestry	Pine	393			3.1							
	Pine chips	394	21.6	72.4	6	52.8	6.1	40.5	0.5	0.09		21.2
	Spruce wood	395	18.1	80.2	1.7	51.9	6.1	40.9	0.3	n/a	n.a	
	Spruce wood	394	18.3	81.2	0.5	52.3	6.1	41.2	0.3	0.1	0.01	20.95
	Spruce bark	394	23.4	73.4	3.2	53.6	6.2	40	0.1	0.1	0.03	21.57
Woody energy crops	Willow wood	397	16.07	82.22	1.71	49.9	5.9	41.8	0.61	0.07	<0.01	19.59
	Hybrid Poplar	397	12.49	84.81	2.7	50.18	6.06	40.43	0.6	0.02	0.01	19.02
	Poplar	393			3.4							
	Eucalyptus 1	393			4.3							
	Eucalyptus 2	393			8.1							
	Eucalyptus (Grandis)	396	16.93		0.52	48.33	5.89	45.13	0.15	0.01		19.35
Energy grasses	Miscanthus	398	16.56	81.5	1.31	48.98	6.02	44.76	0.11	0.03	0.1	19.44
	Switchgrass	399	15.16	73.05	4.62	46.94	6.27	43.26	0.43	n/a	<0.3	17.82
	Switchgrass	397	14.34	76.69	8.97	46.68	5.82	37.38	0.77	0.19	0.19	18.06
	Reed canary grass	399	14.34	76.28	5.4	46.87	6.01	40.66	0.39	n/a	<0.3	17.15
Straw	Wheat straw	397	17.71	75.27	7.02	44.92	5.46	41.77	0.44	0.16	0.23	17.94
	Barley Straw	396	20.9		10.3	39.92	5.27	43.81	1.25			17.31
	Barley straw	394	18.5	76.2	5.3	49.4	6.2	43.6	0.7	0.13	0.27	19.75
	Rape straw	394	17.9	77.4	4.7	48.5	6.4	44.5	0.5	0.1	0.03	20.72
Imports	Sugar cane bagasse	397	11.95	85.61	2.44	48.64	5.87	42.82	0.16	0.04	0.03	18.99
	Palm kernel expeller	399	17.51	78.05	4.44	51.12	7.37	38.71	2.8	n/a	n/a	20
	Olive residue A	399	20.59	69.58	9.83	54.42	6.82	37.36	1.4	n/a	n/a	19.67
	Olive residue B	399	18	74.09	7.9	54.33	7.2	37.08	1.39	0.13	n/a	20.25
	Olive residue C	399	18.26	58.54	23.19	51.38	6.32	40.85	1.45	n/a	n/a	16.1
	Sunflower	393			9.7							
	Sunflower shell	395	19.8	76.2	4	47.4	5.8	41.3	1.4	0.05	0.1	18.9
	Sunflower husk	393	20.9	76	3.1	50.4	5.5	43	1.1	0.03	0.1	20
Waste wood	Sawdust	396	13.9	76.2	2.6	46.9	5.2	37.8	0.1	0.04		18.14
	Sawdust	394	14.3	84.6	1.1	49.8	6	43.7	0.5	0.02		19.83
	Furniture waste	400			3.61						<0.01	20.15
	Forest residues	400			3.97						0.04	20.18

#### 2.4.4 Ash behaviour

All solid biomass and other solid fuels contain mineral matter and organically-bound inorganic elements which remain as solid ash during combustion. Most biomass materials have significant inorganic matter contents and many of the problems encountered with the thermal processing of biomass materials, or the co-processing of biomass with fossil fuels, are associated with the nature and the behaviour of the biomass ash components and the other inorganic constituents. The key technical ash-related problems encountered by operators of biomass thermal processing plants and equipment have been associated with:

- The formation of fused or partly-fused agglomerates and slag deposits at high temperatures within furnaces and reaction vessels, and on the gas-side surfaces of heat exchangers
- The formation of bonded ash deposits and accumulations of ash materials at lower temperatures on the gas-side surfaces of heat exchangers
- The accelerated metal wastage of the gas side surfaces of furnaces, reaction vessels and other plant components due to corrosion under ash deposits, due to ash particle impact erosion or ash abrasion or, in some cases, due a combination of the two effects
- The formation and emission of sub-micron aerosols and fumes
- The impacts of biomass ash components on the performance of exhaust gas cleaning equipment
- The handling and the utilisation/disposal of the ash residues from biomass thermal processing plants, and of the mixed ash residues from the co-utilisation of biomass materials with fossil fuels

In very general terms, the inorganic materials in most solid fuels, including biomass, can be divided into two broad fractions:

- The **inherent inorganic material**, which exists as components of the organic structure of the fuel, and is most commonly associated chemically with the oxygen, sulphur and nitrogen-containing functional groups. These organic functional groups can provide suitable sites for the inorganic species to be associated in the form of cations or chelates. Biomass materials are rich in functional groups containing oxygen, and in some cases, nitrogen and sulphur, and a significant fraction of the inorganic material in some of the lower ash biomass fuels is commonly in this form. It is also possible for some inorganic species to be present in very fine particulate form within the organic structure of some of the fuels, and to behave essentially as an inherent component of the fuel
- The **extraneous inorganic material**, which has been added to the fuel as a result of geological processes, or during harvesting, handling and processing of the fuel. Biomass fuels, for instance, can be contaminated with soil and other materials, which have become mixed with the fuel during collection, handling and storage activities, although this is marginal in volume terms for large-scale supplies

Table 2.24 summarises the ash composition of biomass ashes from the different biomass categories. Note that the total ash content of biomass is usually very low (Table 2.23), but the composition of this ash varies widely. Biomass ashes tend to be rich in a fairly similar suite of inorganic species, i.e. the compounds of calcium, potassium, silicon, phosphorus and magnesium. In very general terms, biomass ashes fall into three main categories:

- High Si high K, low Ca found in grasses and many agricultural residues
- High Si, high K, high Ca found in woods, pits shells etc
- High K, high Ca, high P found in manure

**Table 2.24: Typical ash analysis**

Feedstock category	Feedstock	Ref	Ash composition (%)									
			SiO <sub>2</sub>	Al <sub>2</sub> O <sub>3</sub>	TiO <sub>2</sub>	Fe <sub>2</sub> O <sub>3</sub>	CaO	MgO	Na <sub>2</sub> O	K <sub>2</sub> O	SO <sub>3</sub>	P <sub>2</sub> O <sub>5</sub>
Forestry	Pine	<sup>393</sup>	52				13	4.5	1.9	7.9		
	Pine chips	<sup>394</sup>	68.18	7.04	0.55	5.45	7.89	2.43	1.2	4.51	1.19	1.56
	Spruce wood	<sup>394</sup>	19.3	9.4	0.1	8.3	17.2	1.1	0.5	9.6	2.6	0.1
	Spruce bark	<sup>394</sup>	6.13	0.68	0.12	1.9	72.39	4.97	2.02	7.22	1.88	0.12
Woody energy crops	Willow wood	<sup>397</sup>	2.35	1.41	0.05	0.73	41.2	2.47	0.94	15	1.83	7.4
	Hybrid Poplar	<sup>397</sup>	5.9	0.84	0.3	1.4	49.92	18.4	0.13	9.64	2.04	1.34
	Poplar	<sup>393</sup>	2.8				33	3.7	0.14	18		
	Eucalyptus 1	<sup>395</sup>	41				18	4.2	1.9	8.7		
	Eucalyptus 2	<sup>395</sup>	41				22	2.9	1.2	4.7		
Energy grasses	Miscanthus	<sup>398</sup>	33.8	0.35	0	0.31	6.2	6.55	0.73	37.9	5.54	2.01
	Switchgrass	<sup>399</sup>	61.3	0.85	0.09	0.93	16.5	2.82	0.75	2.76	2.56	3.27
	Switchgrass	<sup>397</sup>	65.18	4.51	0.24	2.03	5.6	3	0.58	11.6	0.44	4.5
	Reed canary grass	<sup>399</sup>	75	0.37		0.04	9.13	1.95	0.25	2.87	1.82	4.09
Straw	Wheat straw	<sup>397</sup>	55.32	1.88	0.08	0.73	6.14	1.06	1.71	25.6	4.4	1.26
	Barley Straw	<sup>396</sup>										
	Barley straw	<sup>394</sup>	50.78	0.67	0.08	0.95	9.89	2.87	1.39	28.18	2.22	2.97
	Rape straw	<sup>394</sup>	40.8	5.45	0.29	2	30.68	2	0.44	13.45	2.67	2.22
Imports	Sugar cane bagasse	<sup>397</sup>	46.61	17.69	2.63	14.14	4.47	3.33	0.79	0.15	2.08	2.72
	Palm kernel expeller	<sup>399</sup>	16.51	0.87	n/a	5.7	11.9	11.51	0.41	21.43	n/a	n/a
	Olive residue A	<sup>399</sup>	21.1	1.94		2.14	15.44	5.78	0.47	31.04	n/a	n/a
	Olive residue B	<sup>399</sup>	10.88	0.85		0.75	9.4	2.87	0.33	32.08	n/a	n/a
	Olive residue C	<sup>399</sup>	67.4	2.74		5.29	19.49	5.25	0.35	4.41	n/a	n/a
	Sunflower	<sup>393</sup>	11				17	3.8	0.55	24		
	Sunflower shell	<sup>395</sup>	29.3	2.9	0.1	2.1	15.8	6.1	1.5	35.6	1.3	4.8
	Sunflower husk	<sup>394</sup>	23.66	8.75	0.15	4.27	15.31	7.33	0.8	28.53	4.07	7.13
Waste wood	Sawdust	<sup>394</sup>	26.17	4.53	0.4	1.82	44.11	5.34	2.48	10.83	2.05	1.82
	Furniture waste	<sup>400</sup>	57.62	12.23	0.5	5.63	13.89	3.28	2.36	3.77	1	0.5
	Forest residues	<sup>400</sup>	17.78	3.55	0.5	1.58	45.46	7.48	2.13	8.52	2.78	0.44

Chloride is the most important halide in biomass, and is present in high concentrations in agricultural residues (straws) in particular – see Table 2.23. During the combustion, the mineral matter such as K, Ca, P, Fe, S and Cl, are volatilized and released into vapour phase. At high temperatures, in the presence of SiO<sub>2</sub> or SiO, K can be absorbed by the silicates to form low melting potassium silicate. The gas phase chemistry is complex, but some of the key transformations are given in Figure 2.38. During the cooling process, the gaseous potassium may condense on the coarse fly ash as KCl (solid) or K<sub>2</sub>SO<sub>4</sub> (solid). This low melting fly ash may stick or form deposits on boiler tubes, creating a low-melting sticky surface. Corrosion may occur via chlorination mechanisms acting in the deposits on



the metal tube surfaces. Deposits in the radiant section of the furnace are referred to as slagging, while those in the convective sections are referred to as fouling.

These two deposition mechanisms can result in boiler operation problems, including reduction of heat transfer, lower efficiencies, erosion, blocking of the ash hopper etc. Agglomeration and sintering of fluid or fixed beds are also issues in biomass combustion, as well as corrosion. All these factors depend upon the deposition and transformation of the inorganic components found in different regions of the combustion boilers. The degrees of fouling and slagging vary with fuel characteristics along with the local gas temperatures, tube temperature and local heat flux on each particle. Biomass has more ash related problems than coal, as certain volatile elements are present in biomass materials, and ash fusion temperatures are generally lower than those of coal.

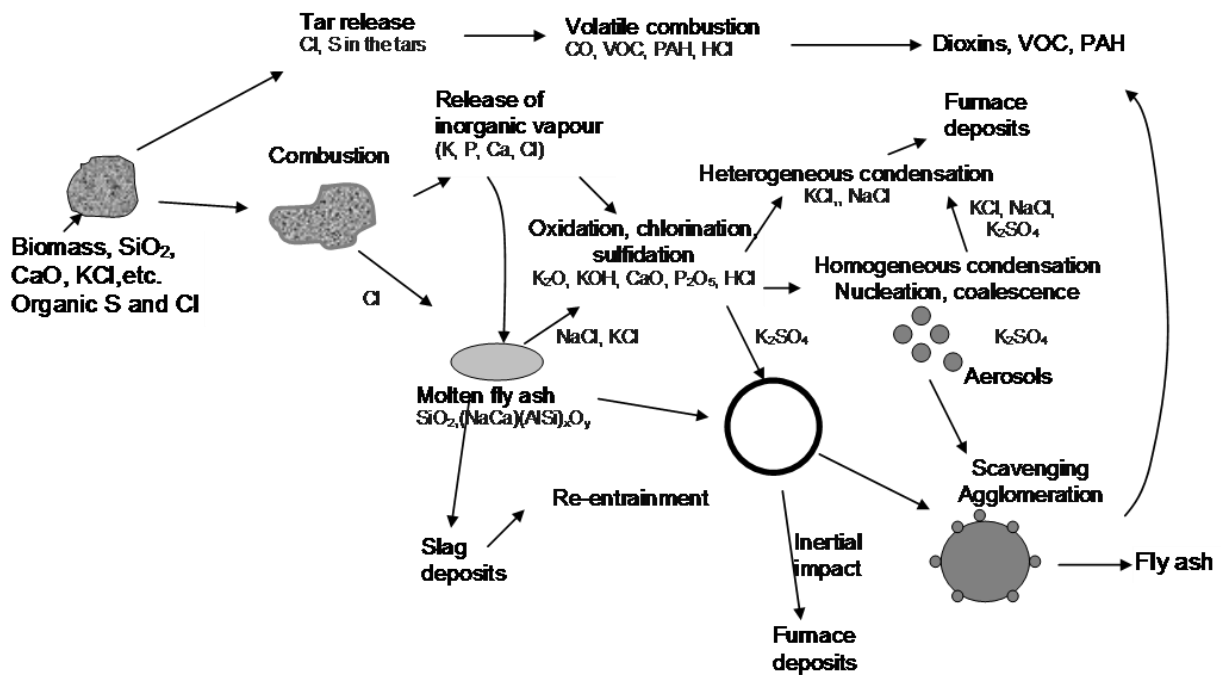

Figure 2.38: Routes to fly ash formation, slagging and fouling during biomass combustion (adapted from <sup>401</sup>)

One of the key properties of fuel ash materials is their behaviour at elevated temperatures and, in particular, their fusion behaviour. The relevance of the ash fusion temperatures to the behaviour of the biomass fuels depends, to some extent on the type of thermal processor. For example, the sintering and fusion of the ash particles on the grates in stoker-fired combustors, and the sintering, fusion and agglomeration of the ash particles in fluidised bed-fired combustors and gasifiers, are important processes, and the tendency to form a fused or partly-fused ash deposits and agglomerates is clearly dependent on the fusion temperatures of the ash. The fusion behaviour of the ashes is also an important factor in determining the propensities of the fuels to form fused or partly-fused slag deposits on the reactor wall surfaces in all thermal processors systems and, in some circumstances, may have an influence on the nature of the fouling deposits that can occur on the heat exchange and other surfaces.

The fusion behaviour of most fuel ashes is a fairly complex phenomenon, which is best described in terms of a melting curve, where the percentage of the ash, by mass, which is fused is plotted against the temperature. The standard Ash Fusion Test, which has been applied for the characterisation of the fusion behaviour of coal ashes for many decades, is based on the determination of three or four

key temperatures on the melting curve. This procedure has been developed and applied specifically for alumino-silicate, coal ash systems, which have very complex melting behaviour. Coal ash systems commonly melt over a fairly wide range of temperatures from around 1000-1500°C, and tend to produce relatively viscous melts. The test becomes more difficult to apply to biomass ashes, most of which are not alumino-silicate systems, and many of which melt at temperatures less than 1000°C. In addition, some of the biomass ashes do not behave in the same way as coal ashes in a number of respects, and caution is needed in the interpretation of the results. The ash melting properties of a number of biomass materials are listed in Table 2.25.

**Table 2.25: Typical slagging and fouling indicators, and melting behaviour**

Feedstock category	Feedstock	Ref	Slagging and fouling indices			Ash fusion temperatures (°C)		
			Alkali index (kg/GJ)	Base to acid ratio	Base %	Deformation	Hemisphere	Flow
Forestry	Pine	393				1190	1220	1280
	Pine chips	394	0.16	0.28	21.48			
	Spruce wood	394	0.02	1.27	36.7			
	Spruce bark	394	0.14	12.77	88.5			
Woody energy crops	Willow wood	397	0.14	15.84	60.34	collapses at 1190		
	Hybrid Poplar	397	0.14	11.29	79.49			
	Poplar	393				>1400	>1400	>1400
	Eucalyptus 1	395				1160	1190	1230
	Eucalyptus 2	395				1150	1240	1260
Energy grasses	Miscanthus	398	0.26	1.51	51.7	920	1070	1110
	Switchgrass	399	0.09	0.38	23.76			
	Switchgrass	397	0.6	0.33	22.81			
	Reed canary grass	399	0.1	0.19	14.24			
Straw	Wheat straw	397,393	1.07	0.62	35.24	850	1120	1320
	Barley Straw	396,401				925	n/a	1100
	Barley straw	394	0.79	0.84	43.28			
	Rape straw	394	0.32	1.04	48.57			
Imports	Sugar cane bagasse	397	0.06	0.36	22.88			
	Palm kernel expeller	399	0.48	2.93	50.94	1070	1140	1180
	Olive residue A	399	1.57	2.38	54.87	1080	1350	1360
	Olive residue B	399	1.27	3.88	45.44			
	Olive residue C	399	0.69	0.5	34.79			
	Sunflower	393				740	1360	1390
	Sunflower shell	395	0.78	1.89	61.1			
Waste wood	Sunflower husk	394	0.45	1.73	56.24			
	Sawdust	394,402	0.07	2.08	64.58	1270	1410	1430
	Furniture waste	400	0.1	0.41	28.93			
	Forest residues	400	0.2	2.99	65.17			

A number of **Slagging and Fouling Indices** are available for the assessment of the propensity of fuel ashes to form deposits in boilers and other plants. The majority of these were originally developed for the assessment of coal ashes, and a detailed description of the technical basis and use of these

indices is presented in Raask<sup>403</sup>. These indices are based either on the fuel ash content and the ash chemical composition, or on the results of the Ash Fusion Test. They have been applied, with appropriate modifications, to the ashes from other solid fuels, including wastes and biomass materials, and to the mixed ashes produced by the co-processing of biomass materials with coal.

The majority of the coal **Slagging Indices** are concerned with the fusion behaviour of the ash or the chemical composition of the ash, commonly the ratio of the acidic metal oxides, (SiO<sub>2</sub> and Al<sub>2</sub>O<sub>3</sub>) to the basic oxides (Fe<sub>2</sub>O<sub>3</sub>, CaO, MgO, Na<sub>2</sub>O and K<sub>2</sub>O). These indices provide a general assessment of the fusion behaviour of the ashes, which is then employed to rank the ash in terms of its propensity to form fused or partially-fused agglomerates and slag deposits. Despite the technical limitations of both of these approaches, they are still used widely in the industry for fuel specification, furnace, reactor and heat exchanger design and for plant operational purposes.

A number of more sophisticated approaches to the assessment of the slagging propensity, for instance based on the use of phase diagrams of the appropriate alumino-silicate systems, or on the use of mineralogical analysis data derived from the characterisation of the fuel using scanning electron microscopes and other advanced techniques, have been developed, however these have enjoyed only relatively limited use within the industry.

Since the majority of the coal ash slagging indices are based on the assessment of the fusion behaviour of alumino-silicate coal ashes, the application to biomass ash systems, which are chemically very different, can be problematic, and great care should be applied when interpreting the conventional Slagging Index values for biomass ashes and to the ashes produced from the co-processing of biomass materials with coals.

Base acid ratio ( $R_{b/a}$ ) is a way of assessing the melting temperature of ash, and is defined in equation (2), where all oxides are weight percents in the ash.

$$R_{b/a} = \frac{Fe_2O_3 + CaO + MgO + K_2O + Na_2O}{SiO_2 + TiO_2 + Al_2O_3} \quad (2)$$

Base percentage alone can also be used and the relationship with ash melting temperature is parabolic in nature, with a minimum at between 30-50% for low rank coals<sup>398,401</sup>. The minimum for biomass appears to be in the same range of base percentages but the melting corresponding minimum temperatures are much lower. Typical minima are ~1150°C for sub-bituminous coals, and less than 1000°C for biomass with 30-50% basic ash components. Typical values of base percentage are also listed in Table 2.25.

The **Fouling Indices** are based principally on the alkali metal content of the fuel. The deposition of the alkali metal compounds on cooled boiler surfaces by a volatilisation/condensation mechanism is considered to be the principal driving force for heat exchanger fouling in coal plants. For most biomass materials, potassium tends to be the dominant alkali metal, and this is generally in a form that is available for release by volatilisation. The fouling indices which have been developed specifically for the assessment of biomass materials tend, therefore, to be based on the total alkali metal content of the fuel (see, for instance, <sup>400</sup>).

The Alkali index (a fouling indicator), is defined in following equation:

$$AI = \left( \frac{1}{Q} \right) Y_f^a (Y_{K_2O}^a + Y_{Na_2O}^a) \quad (1)$$

where  $Q$  is the heating value in GJ/kg,  $Y_f^a$  is the ash fraction, and  $Y_{K_2O}^a$  and  $Y_{Na_2O}^a$  are the fractions of  $K_2O$  and  $Na_2O$  in the ash. Indicators are that an alkali index in the range 0.17-0.34 is indicative of probable fouling, while an alkali index of  $>0.34$  is indicative of almost certain fouling of a problematic nature. Some indicative biomass and coal values are shown in Figure 2.39.

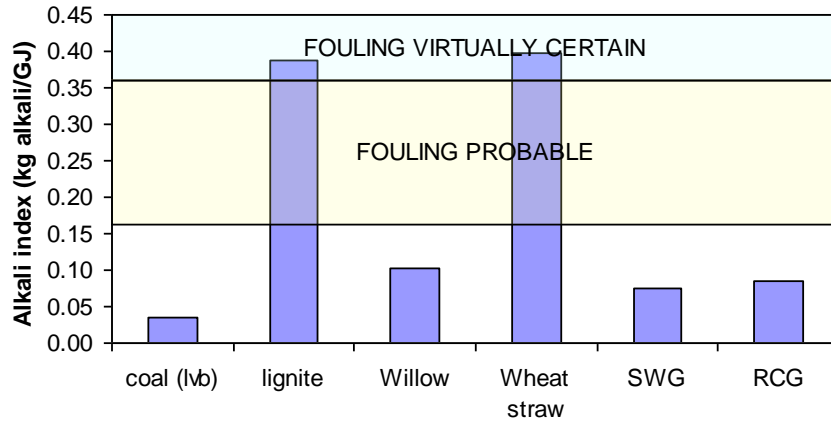

Figure 2.39: Alkali indices of some biomass fuels in comparison to coal

Overall, therefore, a practically useful suite of ash characterisation techniques and ranking methods are available for biomass materials. The majority of these techniques were originally developed and applied for the characterisation of coals and other conventional solid fuels and the study of their behaviour in combustion systems. Because they are already familiar within the energy industry, many of these methods have been adapted for use with biomass materials, and for gasification and pyrolysis systems as well as combustors. As always, great caution should be exercised when applying these procedures and methodologies to materials and processes for which they were not originally developed.

From the material presented in Table 2.25, it is clear that certain types of biomass are potentially more problematic in terms of their deposition behaviour than others:

- Woody or **forestry biomass** tends to have low ash and potassium contents. The principal ash components are calcium/magnesium oxides. A consequence of this is that the softening temperature of woody biomass ash is generally greater than  $1100^{\circ}\text{C}$ , and the slagging and fouling indices are relatively low.
- For the **woody energy crops** (willow and poplar), the alkali index is higher than other woody biomass due to higher bark levels, but generally still below the “fouling probable” threshold
- **Waste woods** are generally similar to forestry biomass in terms of the major ash components and so will have few problems in terms of slagging, fouling and corrosion. However, trace metals will be an issue with treated or painted waste wood material. Also, fuel variability is problematic, with wide ranges in composition because of its heterogeneous nature.
- The **energy grasses** have ash chemistries dominated by potassium oxide and silica. Consequently, melting temperatures are generally lower than the woody biomass, softening at  $< 1000^{\circ}\text{C}$ . The fouling and slagging index values tend to be relatively high

- The **agricultural residues** have high potassium and chloride contents. The ashes are dominated by potassium and silica with ash softening temperatures being well below 1000°C, and very high slagging and fouling indices, usually above the “fouling almost certain” threshold
- The ash chemistries of the **import biomass** types are variable in terms of ash composition and expected ash behaviour. In many cases fouling and slagging may be an issue because of high K and Si contents in the ash. Note also that these types of fuels can be high in nitrogen (Table 2.23); although much of this nitrogen partitions into the volatiles, NO<sub>x</sub> emissions might be affected.

#### 2.4.5 Pre-processing technologies

The key pre-processing options for biomass materials as fuels, including drying, size reduction, densification and thermal processing are described in Table 2.26. The costs and efficiencies of some of the pre-processing technologies have been compared recently by Uslu et al<sup>404</sup>. Evans<sup>405</sup> also conducted a thorough review of the techno-economics of energy densification processes for biomass. The performance and cost of each pre-processing option is given in Table 2.27.

For woody biomass (and some other biomass types), chipping has the highest efficiency of all the processing options, but the chipped product has only a modest bulk energy density.

For the trading and transportation of biomass materials over significant distances, pellets and briquettes are preferred since they provide a uniform fuel with improved energy density. Both fast pyrolysis processes (to produce bio-oils) and torrefaction processes have also attracted attention recently as potential pre-processing technologies for biomass.

**Fast pyrolysis** involves the rapid heating of biomass to temperatures around 500°C for a short period of time in the absence of oxygen, followed by rapid quenching of the resultant vapours to produce a mixture of bio-oils. The chemistry of the pyrolysis process is very complex and the bio-oils contains a large number of oxygenated organic compounds. These include organic acids, aldehydes, alcohols and phenols.

The biggest advantages of fast pyrolysis bio-oils are their high volumetric energy density, and the potentially easier logistics of transporting, storing and utilising a liquid fuel. The bio-oils, however, have relatively low mass energy density and have high water content and acidity. There are also concerns about the long term issues with its storage stability.

There are currently four main commercial/demonstration units are in place for fast pyrolysis, ranging in scale from 5 t/day (BTG Netherlands) to 50 t/day (Ensyn Technologies).

**Torrefaction** is a mild pyrolysis process at temperatures between 200 to 300°C at a residence time of around 30 minutes. Under these conditions, the biomass polymeric structures undergo partial decomposition, with the release of volatile components, to produce a solid product with very different properties from those of the original biomass. The heating value of the biomass increases and the solid becomes hydrophobic, and more friable. When combined with pelletising, the energy density increases even further. The indications are that the hydrophobic nature would make storage easier when compared to raw biomass, because the fuel would not start to degrade, and higher energy contents lower transport and handling costs. However, torrefaction will not significantly reduce sulphur, chlorine and alkali concentrations of the biomass, hence co-firing percentages are still likely to be limited by the same corrosion, slagging and fouling impacts on boiler integrity<sup>406</sup>.

There are a number of demonstration torrefaction plants under development using a wide range of reactor technologies. The largest of these is the 60,000 t/a TOPELL Energy plant which started operation at the end of 2010. Other plants include, Stramproy Green Investment (Netherlands) at 45,000 t/a, Torr-Coal (Netherlands) at 35,000 t/a and the Rotawave (UK) plant under development in British Columbia Canada (110,000 t/a, operational end 2011).

The development of steam exploded biomass pellets is also underway, and this product is also becoming available on the market.

While wood pellets have 10-20% embedded energy, torrefied biomass pellet production is more efficient, because of the reduced energy requirement and costs of milling of the torrefied product compared to raw wood. The torrefied biomass pellet has the highest bulk energy density of the wood products. The costs for torrefied pellets are predicted to be cheaper than for the production of wood pellets by around €0.9/GJ.

Fast pyrolysis oil has the highest bulk (volumetric) energy density of the pre-treated products, but lower efficiencies and higher production costs than the solid biomass products. Standard specifications are available for fast pyrolysis bio-oil (ASTM D7544-09), but standards for torrefied biomass pellets or chips are still under discussion.

**Table 2.26: Status of pre-processing technologies**

Option	Feedstocks	Status/Issues
<b>Chipping</b>	Woody biomass	Commercial – slicers, drum choppers, screw choppers
<b>Pelletising</b>	Woody biomass, herbaceous biomass (grasses and straws), fruit biomass, blends and mixtures	Commercial, ring-dye mill. Requires dry uniform starting fuel. May include binders. Improved energy density.
<b>Briquettes</b>	Woody biomass, herbaceous biomass, blends and mixtures	Commercial
<b>Bales</b>	Cereal crop straw, grass straw, oil seed crops stalks and leaves	Commercial
<b>Torrefaction</b>	Woody biomass, grasses and straws	Pilot/Demonstration stage. Issues in temperature control and process control and optimisation for pelletising. Improved energy density and milling performance. Combined with pelletising gives greatly improved energy density
<b>Pyrolysis oil</b>	Woody biomass, grasses and straws, fruit biomass.	Demonstration stage. Issues with acidity and stability. High water content, low heating value. Energy density greatly improved.

**Table 2.27: Performance of pre-processing technologies**<sup>404, 405</sup>

Option	Net Efficiency <sup>405</sup>	Production Costs (€2008/GJ)	Bulk density (kg/m <sup>3</sup> )	Bulk energy density (GJ/m <sup>3</sup> )	Typical prices seen by users
<b>Chipping</b>	<0.5% embedded energy		200-450	4.2-9.4	30-60 £/odt for large scale electricity <sup>407</sup>
<b>Pelletising</b>	84-88% 89%	3.4	500-650	7.8-10.5	129-133 €/odt (wood) <sup>408</sup> 105-135 £/odt (imports) for large scale electricity <sup>407</sup>
<b>Briquettes</b>					
<b>Bales</b>			135-165		38-50 £/t (wheat) <sup>409</sup> 50-70 £/t (barley) <sup>409</sup>
<b>Torrefaction</b>	90-95% Chip: 89% Pellet: 86%	Chip: 3.2 Pellet: 2.5	Chip: 230 Pellet: 750-850	Chip: 4.6 Pellet: 14.9-18.4	
<b>Pyrolysis oil</b>	64% 66%	6-12	1200	20-30	10.3 £/GJ (2008) <sup>19</sup>

#### 2.4.6 Impact of feedstock on biomass conversion technologies

For both combustion and gasification systems, the plant designer and operators will be required to work with a fuel specification which will be developed by the project team. The development of the fuel specification will be a compromise between the desire to minimise process risks and costs by only using the highest grade biomass and the requirement to minimise the delivered fuel costs and maximise the availability of fuel by widening the fuel specification. The situation is further complicated by the requirement to consider the requirements of both the specific arrangements being made for biomass transport, handling, storage and on-site pre-processing, and the fuel quality requirements of the thermal process involved.

In most situations a relatively dry biomass fuel is preferred, because of concerns about the deterioration in quality of biomass materials with moisture contents above 15-20% during storage. For long distance transportation and ease of handling and storage, a dried, densified such as a pellet, lozenge or briquette is usually preferred for most applications. Specialist equipment is required for the transport, handling and storage of biomass materials, such as straws and grasses, in baled form.

Most conventional bulk handling, storage and feeding systems prefer relatively dry material in chip, granular or pelletised form. Special care is needed to control the generation of dust from biomass for safety and environmental reasons. This may mean specifying the fines contents of delivered fuels, and the mechanical strength of pellets or briquettes, etc.

In general terms, the thermal process can be tailored to the fuel quality. When properly designed and operated, combustion and gasification systems can be used successfully to recover energy from biomass fuels as different in properties as wood pellets, sugar cane bagasse, poultry litter and black liquor.

When co-utilising biomass with coal in thermal processing equipment designed principally for coal, the biomass quality specification will depend on the coal and biomass quality and the co-firing ratio. Obviously, the fuel specification can generally be much wider at lower co-firing ratios.

When converting existing coal boilers to 100% biomass firing (of current interest in Europe and North America), the biomass specification will be constrained by concerns about ash-related impacts, so that there will be limits placed on the ash content and key ash quality parameters.

The impacts of both the physical form of the feedstock and its chemical characteristics on different power conversion technology options are summarised in Table 2.28 and Table 2.29. For any individual feedstock, there is no clear distinction (in terms of suitability or flexibility) between using combustion as opposed to gasification. Rather, the critical feedstock factors to control, and any necessary pre-processing, depend more on the individual reactor type and operating conditions

- For combustion, ash behaviour, corrosion, fouling and slagging are the main issues. Many of the technical difficulties also arise from the much smaller bulk density and bulk energy density of biomass (compared to coal), and, for PCC applications, size reduction and mill performance are key factors affecting throughput and efficiency
- For gasification, there are similar operational issues for biomass and coal, but several technical differences. These are related to the higher reactivity of biomass, the propensity for tar formation at low temperatures, the low ash melting temperatures and the corrosive/aggressive nature of the ash, and the high bulk density and fibrous nature of biomass which makes transportation, storage, handling and size reduction challenging

---

<sup>388</sup> Ofgem “Sustainability Report on biomass fuelled generating stations for 2009/10 obligation period”, available at: <http://www.ofgem.gov.uk/Pages/MoreInformation.aspx?docid=248&refer=Sustainability/Environment/RenewableFuelledStations>

<sup>389</sup> E4tech (2011) “Development of illustrative scenarios describing the quantity of different types of bioenergy potentially available to the transport sector in 2020, 2030 and 2050”, part of the Modes project for DfT

<sup>390</sup> DECC (2011) “2050 Pathways Analysis”, available at: <http://www.decc.gov.uk/en/content/cms/tackling/2050/2050.aspx>

<sup>391</sup> Biomass Energy Centre, “Effect of moisture content in biomass materials”, accessed 16<sup>th</sup> June 2011, available at: [http://www.biomassenergycentre.org.uk/portal/page?\\_pageid=75,17656&\\_dad=portal&\\_schema=PORTAL](http://www.biomassenergycentre.org.uk/portal/page?_pageid=75,17656&_dad=portal&_schema=PORTAL)

<sup>392</sup> British Standard specification for solid biofuels, CEN/TS 14961: 2005

<sup>393</sup> Fernandez Llorente, M. J. & Carrasco García, J. E. Comparing methods for predicting the sintering of biomass ash in combustion. *Fuel*, 2005, 84, 1893-1900

<sup>394</sup> Vassilev, S. V., Baxter, D., Andersen, L. K. & Vassileva, C. G. An overview of the chemical composition of biomass. *Fuel*, 2010, 89, 913-933

<sup>395</sup> Demirbas, A. Combustion characteristics of different biomass fuels. *Prog Energy Combust Sci*, 2004, 30, 219-230

<sup>396</sup> Sami, M., Annamalai, K. & Wooldridge, M. Co-firing of coal and biomass fuel blends. *Progress in Energy and Combustion Science*, 2001, 27, 171-214

<sup>397</sup> Jenkins, B. M., Baxter, L. L., Miles Jr., T. R. & Miles, T. R. Combustion properties of biomass. *Fuel Processing Technology*, 1998, 54, 17-46

<sup>398</sup> Baxter X. (2011) Combustion Properties of Miscanthus – Impact of Ash and Agronomy. PhD thesis, University of Leeds

<sup>399</sup> Darvell, L. I., Jones, J. M., Gudka, B., Baxter, X. C., Saddawi, A., Williams, A. & Malmgren, A. Combustion properties of some power station biomass fuels. *Fuel*, 2010, 89, 2881-2890.

<sup>400</sup> Miles, T. R., Miles Jr., T. R., Baxter, L. L., Bryers, R. W., Jenkins, B. M. & Oden, L. L. Boiler deposits from firing biomass fuels. *Biomass and Bioenergy*, 1996, 10, 125-138.

<sup>401</sup> Bryers, R.W. Fireside slagging, fouling, and high temperature corrosion of heat transfer surfaces due to impurities in steam-rising fuels. *Prog Energy Combust Sci*; 1996, 22, 29-120.

<sup>402</sup> Kupka, T., Mancini, M., Irmer, M. & Weber, R. Investigation of ash deposit formation during co-firing of coal with sewage sludge, saw-dust and refuse derived fuel. *Fuel*, 2008, 87, 2824-2837

<sup>403</sup> Raask, E. The model of occurrence and concentration of trace elements in coal, *Prog Energy Comb Sci* 1985, 11, 97-118

<sup>404</sup> Uslu, A., Faaij, A.P.C. & Bergman, P.C.A. Pre-treatment technologies, and their effect on international bioenergy supply chain logistics. *Techno-economic evaluation of torrefaction, fast pyrolysis & pelletisation*. *Energy*, 2008, 33, 1206-1223

<sup>405</sup> Evans, G. (2008) “Techno-Economic Assessment of Biomass ‘densification’ Technologies”, NNFFC

<sup>406</sup> Kleinschmidt, C. “Overview of international developments in torrefaction” Central European Biomass Conference 2011

<sup>407</sup> E4tech (2010) “Biomass prices in the heat and electricity sectors in the UK” report for DECC, January 2010

<sup>408</sup> APX-ENDEX Market data on biomass wood pellets. <http://www.apxendex.com>

<sup>409</sup> Farmers Weekly Interactive – Weekly feed prices for Hay & Straw (May 2011). <http://www.fwi.co.uk/prices-trends/>



**Table 2.28: Impact of feedstock physical and chemical properties on combustion conversion technologies**

Power conversion technology	Coal combustion	Biomass combustion			
	Pulverised coal, direct co-firing	Pulverised coal, converted to 100% biomass	Grate	BFB	CFB
<b>Chemical composition risks</b>	Forestry: variable composition, high ash bark Energy crops/grasses: ash slagging may be problematic at high ratios Straws: high alkali & Cl, therefore slagging, fouling, corrosion and aerosol release may be issues Waste Woods: trace metals		Biomass high in Cl and alkalis can lead to serious deposit formation on the superheaters	Ash agglomeration of high alkali biomass fuels can occur above 850°C, high alkali also responsible for corrosion problems	
<b>Physical form requirements</b>	Size reduction to the mm scale a general issue, due to the low grindability of most biomass		Wide range of particle sizes and moisture contents is acceptable, can take chips, shredded bales, briquettes, and pellets, as well as torrefied material	Mixtures of different kinds of biomass can be fired, and high moisture fuels are acceptable Chips and pellets preferred for feeding (<~80mm)	Mixtures of different kinds of biomass can be fired, and high moisture fuels are acceptable Chips and pellets preferred for feeding (<~50mm)
<b>Pre-processing aspects</b>	Pellets or torrefied biomass preferred due to defined specifications, and low moisture contents Torrified biomass also has the potential to be used at high percentages in existing coal handling and milling operations. If not torrefied, biomass is usually limited to ~10% co-firing before coal mill performance suffers Fast pyrolysis bio-oil can be easily injected		None required, however drier input biomass increases plant efficiency	Only chipping or pelletising required, low cost	
<b>Unsuitable feedstock types, or modifications required</b>	Particulate and catalyst controls for NO <sub>x</sub> ESP operation modification may be necessary for 100% biomass Control of aerosols and other airborne emissions Separation of uncontaminated wood, trace metal monitoring for WID compliance		Control of furnace temperatures and homogeneous fuel and air flows to minimize hot spots and help avoid slag formation. Automatic heat exchange cleaning has been used in some installations to prevent ash deposit formation and corrosion	Temperature control important, 650-900°C to prevent ash sintering in the bed Corrosion problems can be overcome with refractory-lined superheaters Control of trace metals and other airborne emissions needed to ensure WID compliance	

**Table 2.29: Impact of feedstock physical and chemical properties on gasification conversion technologies**

Power conversion technology	Coal gasification	Biomass gasification		
	IGCC, direct co-firing	IGCC, converted to 100% biomass (Entrained flow)	BFB	CFB and Dual fluidised bed
<b>Chemical composition risks</b>	Forestry and woody energy crops: impact of alkali, dust etc. on gas cleaning & ash utilisation Energy grasses and straws: HCl & aerosols leading to corrosion & potential emissions Waste woods: trace metals	Biomass ash melting temperatures should be >950°C to avoid bed agglomeration		
<b>Physical form requirements</b>	Delivery, storage, dust and explosion hazard, and preparation are all issues Size reduction (<~1.5mm), moisture content (< ~15%) needed	Need chipped material, although pellets and briquettes are also suitable. Size can vary between <50 – 150mm Up to 40-50% moisture acceptable	Need chipped material, although pellets and briquettes are also suitable. Size usually <20mm Up to 40-50% moisture acceptable	
<b>Pre-processing aspects</b>	Large energy input required in milling fibrous biomass down to particles <~1.5mm. Torrefied biomass would be preferred, since 70-90% lower grinding energy Pyrolysis oil is suitable because liquid pumping	Only chipping or pelletising required, low cost		
<b>Unsuitable feedstock types, or modifications required</b>	Inerting may be required Separation of uncontaminated wood Cl restriction may rule out some straws and energy grasses	Expensive catalytic bed additives, such as olivine or dolomite, can be used to prevent ash agglomeration. Otherwise ash melting temperatures rule out most straws and residues		

### 3 Technology combinations

#### 3.1 Combinations and groupings of technologies

Using the information collected in Section 2 regarding the different components within a full biomass CCS route, we next examined each combination of technologies as a whole integrated system. However, given that 11 power conversion technologies, 14 carbon capture technologies, and 6 main feedstock groups have been identified within the scope of the project, working through each of the 924 combinations in turn would have been impractical.

Therefore, we will focus on those combinations of power conversion and carbon capture technologies that we know from Section 2 are compatible – this follows the same logic as behind Figure 1.1 e.g. matching combustion boilers with post-combustion capture etc.

Component groupings have been used where individual technologies share many similarities, or have no distinctive impacts within a combination – i.e. the combinations appear very similar. This grouping is important, so that the combination recommendations made in Deliverable 1.2 will be sufficiently distinctive. The 28 combinations and groupings that we assessed for WP1.2 are shown in Table 3.1.

The suitable feedstocks for each combination are primarily determined by the power conversion technology, and not the capture technology. The preference for biomass that is dry, friable, with low ash and alkali contents, and high ash fusion temperatures (e.g. forestry wood pellets) is fairly universal across the different power conversion technologies. Likewise, most technologies would struggle to use very wet biomass (out of scope), or biomass that has high ash and alkali contents, and low ash fusion temperatures (e.g. most straws). It is also likely that there will be a large supply of feedstocks that are suitable for every power conversion technology – either as UK forestry chips or pellets currently, or increasingly imported woody energy crops and torrefied pellets in the future. Therefore, feedstock suitability is not a primary determinant as to whether a particular combination should be progressed or not in Deliverable 1.2, and hence feedstocks were not included in the power-capture combinations.

**Table 3.1: Power-capture technology combinations proposed for assessment**

		Post-combustion					Oxy-combustion			Pre-combustion					
		Solvent scrubbing, e.g. MEA, chilled ammonia	Low-temp solid sorbents, e.g. supported amines	Ionic liquids	Enzymes	Membrane separation of CO <sub>2</sub> from flue gas	High-temp solid sorbents, e.g. carbonate looping	Oxy-fuel boiler with cryogenic O <sub>2</sub> separation	Oxy-fuel boiler with membrane O <sub>2</sub> separation	Chemical-looping-combustion using solid oxygen carriers	IGCC with physical absorption e.g. Rectisol, Selexol	Membrane separation of H <sub>2</sub> from synthesis gases	Membrane production of syngas	Sorbent enhanced reforming using carbonate looping	ZECA concept
<b>Coal IGCC gasification</b>	Direct cofiring	Not feasible					Not feasible			15	17	19	21	23	
	Conversion to 100% biomass	Not feasible					Not feasible			15	17	19	21	23	
<b>Pulverised coal combustion</b>	Direct cofiring	1	3	5	5a	7	9	11	11a	13	Not feasible				
	Conversion to 100% biomass	1	3	5	5a	7	9	11	11a	13					
<b>Dedicated biomass combustion</b>	Fixed grate	2	4	6	6a	8	10	12	12a	14					
	Bubbling fluidised bed	2	4	6	6a	8	10	12	12a						
	Circulating fluidised bed	2	4	6	6a	8	10	12	12a						
<b>Dedicated biomass gasification</b>	Bubbling fluidised bed	Not feasible					Not feasible			14	16	18	20	22	24
	Circulating fluidised bed	Not feasible					Not feasible			14	16	18	20	22	24
	Dual fluidised bed	Not feasible					Not feasible			14	16	18	20	22	24
	Entrained flow	Not feasible					Not feasible			14	16	18	20	22	24

### 3.2 Global demonstration projects

This section will provide an overview on those international CCS demonstration activities that are planning to use biomass. The collected project information is summarised to provide the initial trends in biomass utilisation in the CCS sector, which technology combinations already look promising, and where there might be gaps. These factors will have an impact on the recommendations made in Deliverable 1.2, as the consortium will need to bear in mind a combination of UK capabilities, opportunity spaces, and additionality.

A list of global CCS activities **relevant to biomass** is provided in Table 3.2. It should be noted that some of these projects are well publicised, with public funding, and hence there is plenty of information available. For other projects which may have become dormant since the date of the information sources used, it has been much harder to find certain pieces of data – especially hard to find was information regarding the proposed co-firing %. Furthermore, different reports and press releases often contradict each other, especially with regards to the project timelines, and the proposed scale of the capture technology.

#### *Key messages*

Currently all the planned global demonstration projects involving the use of biomass are proposing to directly co-fire biomass with coal at existing or soon-to-be-built power stations. None of the global demonstration projects considers CCS at a dedicated biomass power plant. Out of the 11 pilot/demonstration projects, only two are currently in operation: the Schwarze Pumpe oxy-fuel plant in Germany, and the Buggenum IGCC plant in the Netherlands. For the other projects it is necessary to differentiate between the power plant and the capture unit timescales: several power plants are currently under construction, but almost all capture units are still in the planning stage and only expected to commence operation in the period 2014 to 2017.

Between them, the Netherlands and the UK have over half of all of the biomass co-firing CCS projects internationally. However, the biomass CCS projects in the Netherlands are generally at large scale, and at newly built power plants. In the UK, two out of the three projects will be retrofits at a smaller scale. The four remaining international projects are located in Germany, Poland, Italy and Spain. Interestingly, only one CCS project in North America is currently planning to use biomass, and none in Asia – all of the CCS developments in China to date are purely focused on coal.

The main technology combinations proposed, unsurprisingly, correspond to the use of components with the highest TRLs. These are pulverised coal combustion with post-combustion amine scrubbing, IGCC with pre-combustion capture and oxy-fuel combustion. Outside the three main technologies, none of the advanced capture technologies have any demonstration plans involving biomass yet.

Concerning the scale, the power plants range from 600 MW to 1,852 MW<sub>e</sub> gross output for PCC boilers, linked to smaller post-combustion capture units at scales of between 35 and 400 MW<sub>e</sub>. Current IGCC power plants are in a smaller range between 140 and 250 MW<sub>e</sub>, and oxy-fuel between 30 to 323 MW<sub>e</sub>. The proposed biomass co-firing percentage varies from 10% to 50%, although half of the projects did not provide this information.

**Table 3.2: Global CCS demonstration projects in the power sector, involving biomass** <sup>410,411,412,413,414</sup>, other references in separate Annex

Project name	Partners	Technology	Scale	Fuel type	% biomass	Current stage	Start up
Schwarze Pumpe, Brandenburg, Germany	Vattenfall Alstom, Linde, Babcock Bersig Service Group, Siemens/Emis Electrics, Trema, Hitachi	Pulverised coal Oxyfuel	30MW (oxyfuel)	Lignite, Tests with biomass planned	Only feasibility studies / testing	Operation phase 2008 - 2014	Since 2008
Buggenum, Limburg, Netherlands <sup>415</sup>	Nuon (owned by Vattenfall), ECN, Delft, KEMA	IGCC Pre-combustion	253 MW 20MW capture unit treats 8% of syngas, 10ktCO <sub>2</sub> /yr	Coal Sewage sludge, waste wood and chicken litter	Up to 30%	Operation phase for 24 months	Since April 2011
Nuon Magnum, Eemshaven, Netherlands	Nuon (owned by Vattenfall)	IGCC (Shell gasifier) Pre-combustion	1200MW	Multifuel Phase 1: Natural gas Phase 2: Gas, coal, biomass, sewage sludge, refuse	Unclear	Power plant under construction Capture unit in planning	Power plant: 2012 Capture unit not before 2020
RWE Eemshaven, Netherlands	RWE, Essent	Pulverised coal Post-combustion (technology choice end of 2011)	1600MW Capture unit: 35-250MW (depending on source)	Coal, biomass	10%	Power plant under construction Capture unit in planning	Power plant: 2013 Capture unit in 2016
Rotterdam, Netherlands <sup>416</sup>	Essent, Shell	IGCC Pre-combustion	1000MW Capture unit size?	Hard coal, biomass	?	?	2016
ROAD, Maasvlakte, Netherlands	Joint-venture of E.ON Benelux and Electrabel (GDF Suez)	Pulverised coal Post-combustion (amine scrubbing)	1070 MW (E.ON) 800 MW (Electrabel) 250MW capture unit for both plants	Coal, woodchips (E.ON) Coal, biomass (Electrabel)	20% for E.ON 50% for Elect-rabel	Both power plants under construction Capture unit in planning	Power plant: 2012/13 Capture unit in 2015
Longannet, Fife, Scotland, UK	Scottish Power Aker Clean Carbon	Pulverised coal Post-combustion retrofit	2x 600MW with co-firing ability	Coal, biomass Unsure if will co-fire in the future	?	CCS in FEED, awaiting UK completion result	2014
Hunterston, UK	Peel Energy, Doosan Power Systems, RWE npower	Ultra-super critical boiler technology Post-combustion (amine scrubbing, switch to chilled ammonia if viable)	Gross: 1852MW (2x926MW) Net: 1724MW CCS 400MW of gross output	Coal, wood pellets and wood chips	14%	Power plant and CCS unit both in application stage.	2017
Alcan Lynemouth, Teeside, UK <sup>417</sup>	Progressive Energy, Rio Tinto Alcan	IGCC retrofit (from current PCC unit) Pre-combustion	140MW (conversion of one 140MW unit to IGCC at existing 420MW power plant) Capture of 2.5MtCO <sub>2</sub> /yr	Bituminous coal, sawdust, wood pellets, olive residues	?	On hold. Financial investment decision due in 2011.	2015
Killingholme, Yorkshire, UK	C.GEN	IGCC Pre-combustion	520MWe 10ktCO <sub>2</sub> /day captured	Hard coal Woodchips Petcoke	Up to 30%	Awaiting NER300 decision	2015

Compostila, Cubillos de Sil, Spain	Endesa, Foster Wheeler, Ciuden	Circulating Fluidised Bed (CFB) supercritical Oxy-Combustion Oxy-combustion	1 <sup>st</sup> phase: 30MW pilot plant 2 <sup>nd</sup> phase: 323MW demo plant	Coal, biomass	?	Pilot plant under construction Demo plant in planning	Demo plant in 2015
Porte Tolle, Italy	Enel, Aker Clean Carbon	Retrofit from oil plant to USCPC Post-combustion (amine scrubbing)	660MW planned USC unit as part of a 1980MW plant 250MW capture unit	Coal, biomass	unclear	Power plant in FEED Capture unit in planning	Capture unit in 2015
Varo, Sweden	Sodra Skogsagarna pulp and paper mill	Post-combustion Retrofit	?	?	?	?	?
Kedzierzyn, Poland <sup>418</sup>	PKE/ZAK	IGCC as part of a chemicals syngas and methanol plant Pre-combustion	250MW <sub>e</sub> , 125 MW <sub>th</sub> , 205MW <sub>s</sub> syngas	Coal, biomass	20%	Construction	2015 (full capacity in 2020)
Hodonion, Czech Republic	Cez	Post-combustion, retrofit Retrofit	105MW Capture unit size?	Lignite, biomass	?	?	2015
North Dakota, USA	Bioreco Energy & Environment Research Centre at University of North Dakota	Next-generation gasification Pre-combustion	?	?	?	?	2012

<sup>410</sup> Global CCS Institute, Strategic Analysis of the Global Status of Carbon Capture and Storage, Report 5: Synthesis Report, Final Report 2009.

<http://www.globalccsinstitute.com/sites/default/files/Report%205-Synthesis%20Report.pdf>

<sup>411</sup> Global CCS Institute, The Global Status of CCS: 2010. <http://www.globalccsinstitute.com/resources/publications/global-status-ccs-2010>

<sup>412</sup> Zero Emission Platform (ZAEF), Current list of Announced European CCS Demonstration Projects, November 2008. Available at: <http://www.zero-emissionplatform.eu/website/docs/ETP%20ZEP/EU%20Demonstration%20Programme%20for%20CCS%20-%20ZEP%27s%20Proposal.pdf>

<sup>413</sup> Tier, S., Hetland, J., Lindeberg, E., Torvanger, A., Buhr, K., Koljonen, T., Gode, J., Onarheim, K., Tjernshaugen, A., Arasto, A., Liljeberg, M., Lehtila, A., Kujanpaa, L., and Nieminen, M., Potential for Carbon Capture and Storage (CCS) in the Nordic Region. VTT Tiedotteita – Research Notes 2556, Espoo 2010. Available at: <http://www.vtt.fi/inf/pdf/tiedotteet/2010/T2556.pdf>

<sup>414</sup> Bjorkqvist, C., Progress Towards Implementation of IGCC-CCS in Europe, ICEPAG 2010, International Colloquium on Environmentally Preferred Advanced Power Generation, Costa Mesa, California, February 9-11, 2010. Available at: <http://www.h2-igcc.eu/Pdf/ICEPAG-Final.pdf>

<sup>415</sup> Powergenworldwide.com (2010) "CCS catch-up project: the next stage for Nuon's Buggenum", available at: [http://www.powergenworldwide.com/index/display/articledisplay/8675641419/articles/power-engineering-international/volume-18/issue\\_5/features/CCS\\_catch\\_up\\_project\\_the\\_next\\_stage\\_for\\_Nuons\\_Buggenum.html](http://www.powergenworldwide.com/index/display/articledisplay/8675641419/articles/power-engineering-international/volume-18/issue_5/features/CCS_catch_up_project_the_next_stage_for_Nuons_Buggenum.html)

<sup>416</sup> [http://www.essent.eu/content/about\\_essent/news/archive/essent\\_and\\_shell\\_take\\_first\\_step\\_toward\\_low-co2\\_power\\_plant.html](http://www.essent.eu/content/about_essent/news/archive/essent_and_shell_take_first_step_toward_low-co2_power_plant.html)

<sup>417</sup> The 850MW IGCC power plant that is part of the North East CSS Cluster is not included in this table as no biomass feedstock input is mentioned.

<sup>418</sup> PKE Grupa Tauron and Zaklady Azotowe Kedzierzyn SA (ZAK). Polygeneration power plant with CO<sub>2</sub> capture demonstration project Kedzierzyn. Available at: [http://www.pke.pl/sites/default/files/PPP\\_eng.pdf](http://www.pke.pl/sites/default/files/PPP_eng.pdf)

## 4 Assessment criteria

Once the combinations and groupings were agreed, in WP1.2 the TESBIC project partners then assessed each combination against the criteria set out in Table 4.1. These criteria cover a range of different development, techno-economic, feedstock, feasibility and UK aspects. This assessment shares many similarities with the component reviews in Section 2, with much of the information coming from the work completed in WP1.1, but thinking of the whole system, as opposed to individual components.

With input from ETI, the consortium members agreed a prioritisation for these criteria, in order to guide our recommendations at the end of Deliverable 1.2. The most important criteria are those highlighted in bold below. These key criteria are a good mix of technical risk, economic attractiveness, and applicability to the UK. Evidence on the other criteria was gathered and discussed, but these secondary criteria only influenced the ranking of a technology if there were major issues with them.

When conducting the assessments, written justifications were provided for each criterion – the highlights of which are given in Section 5. Quantitative scores between 1 (poor) and 5 (excellent) were also provided, although these were only used as a secondary comparative measure: the D1.2 recommendations were primarily based on the qualitative assessments and evidence gathered.

**Table 4.1: Combination assessment criteria**

Category	Criteria
Development aspects and prospects	Key drivers for development
	<b>Key development issues, potential show-stoppers</b>
	Main players internationally
	Pilot/demonstration/commercial plants and R&D activities
	Current TRL, and <b>likely TRL in 2020</b>
	Environmental issues
Techno-economics	Equipment scales (MW min, MW max), suitability for small-scale
	<b>Plant LHV efficiency with capture</b>
	Flexibility, ability to load follow
	<b>Capital cost with capture</b>
Feedstocks and feasibility	Contaminants of risk, required specifications
	Any necessary pre-processing required, benefits
	Appropriate biomass feedstocks, robustness to variability
	Maximum % co-firing allowable / dedicated biomass
	Technical feasibility of component combination
	Ease of changing to high co-firing / complete conversion
	Implications of retrofitting capture versus new build
UK aspects	UK activities and capabilities
	Opportunity space, IP considerations
	<b>UK deployment potential</b>
	Timing of demonstration plants



#### 4.1 Description of the assessment criteria chosen

Based on the feedback from ETI, this section provides some further explanation behind the choice and relative importance of each of the criteria used in the WP1.2 combination assessments.

##### ***Development aspects and prospects***

Understanding the current level of development of a technology combination provides a solid basis for discussion of its future prospects, hence the current TRL is a useful indicator to assess. The number of academics, research institutions and industrial players working on the technology around the world, and the scale and status of currently operating or planned pilot, demonstration and commercial plants are strong indicators of the level of interest and investment in the technology combination, and how rapidly the technology might be expected to progress.

Setting the current TRL, and gauging the trajectory for its increase over the next 10 years then leads to an assessment of the likely TRL in 2020. This is judged to be a key criterion, since as mentioned above in Section 1.4, unless a technology is likely to reach TRL 5 by around 2020, then commercial availability (TRL 8) is unlikely to be achieved before 2035, and hence there will not be any significant deployment by 2050.

However, as well as the current levels of activity and stage of development, there also has to be consideration given to the strength of the drivers (market pull) for the technology, as well as the severity of the development issues that might slow development, and have to be overcome to reach commercial maturity. Any significant environmental or health and safety issues need also to be considered. The identification of potential show-stoppers is vital to ensure that the risks behind each particular technology combination are fully understood, as failure to address these risks could lead to future failures or hamper development.

##### ***Techno-economics***

At least one of the technology combinations recommended for progression has to be suitable for small-scale power applications (i.e. approximately 10 to 30 MW<sub>e</sub>). This is because ETI wish to understand the flexibility that a plant of this scale could provide in a future energy systems context, with possible CO<sub>2</sub>, H<sub>2</sub> or syngas infrastructure configurations, and the ability to source all of the plant's required feedstock locally, without necessarily having to rely on imports (as is generally the case for larger plants >100 MW<sub>e</sub>).

Therefore, assessing the minimum and maximum scales of the power generation and carbon capture technologies, and the likely scales of operation for the combination will allow a judgement to be made regarding suitability of the combination for small-scale power applications, and identify any scale-up issues or scale mis-matches between power and capture components.

Many sources focus on the %-point efficiency penalty imposed by adding CO<sub>2</sub> capture. However, in this study, there are several novel integrated power/capture technologies (e.g. ZECA concept, Chemical Looping Combustion) that do not operate without capture. There are also different baseline technologies used, with PCC plants for post-combustion and oxy-combustion capture, but a higher efficiency coal IGCC baseline used for pre-combustion capture technologies. Therefore, the use of efficiency penalties was not considered useful – instead, the overall plant LHV efficiency with capture was estimated. This value is of key importance, because coal and biomass prices contribute to a very

substantial proportion of the plant's levelised cost of electricity. Higher efficiency plants do not have to source as much biomass in order to generate the same power output as lower efficiency plants, which is likely to mean more local, cheaper feedstocks can be used (import reliance can be reduced).

The ability of a power plant to load follow is not of primary importance, since additional base load generation can be accommodated on most grid networks. However, the competitive time-of-day pricing market mechanisms present in certain countries can economically favour the ability of new plants on the system to load follow – it is our judgement that this may be the case in the UK to 2050 as increasing levels of intermittent renewables (e.g. onshore and offshore wind) are added to the network.

Capital costs are always a key factor in any investment decision, and especially as capital costs of plants with CO<sub>2</sub> capture are usually significantly higher than equivalent plants without capture. Operating costs and fuel costs are also important factors for the levelised cost of electricity, but when comparing technology combinations side-by-side, the same fuel costs are likely to be used throughout, and operating costs are generally taken as a fixed percentage of the capital costs (e.g. 4%).

### ***Feedstocks and feasibility***

As discussed above, feedstock suitability is primarily determined by the power conversion technology, with fuel, ash and contaminant properties already discussed in Section 2.4.6.

There is, however, some value in assessing if the combination has any particular contaminants of risk or required feedstock specifications, and the robustness to variable feedstock quality. The maximum co-firing % is again primarily determined by the power conversion technology, although there are different limits for some of the more novel integrated power/capture systems. Based on discussion from ETI, the co-firing of biomass in coal systems is seen as being equally important as the use of biomass in dedicated power plants.

It is interesting to know if any of the component technologies have already been combined, for non-power applications, or with one component at a different scale to that proposed in the combination (e.g. acid gas removal for IGCC plants is usually just for H<sub>2</sub>S, but can be enlarged to also capture CO<sub>2</sub>), as this is an indication that there should be fewer process integration issues to overcome than for those components not yet combined at the scales considered.

The ease of changing to high co-firing percentages, or complete conversion to 100% biomass, indicates the possible costs and industry willingness to utilise more biomass in their existing plants. The question of whether CO<sub>2</sub> capture is able to be retrofitted to an existing plant, or has to be built as part of a new power project has implications for near-term demonstration opportunities, as well as the long-term deployment options to 2050 – ETI consider that both timeframes are important. In general, new plants properly designed with capture already included will be cheaper, more compact and more efficient than when adding capture onto an existing plant. The vast majority of the UK network equipment and power plants in use today will not be around in 2050, hence retrofitting to today's existing plants will not have a large impact on 2050 deployment, or create any lock-in. However, new biomass power plants and fossil CCS projects planned for construction in the 2015 timeframe (and beyond) are likely to still be around in 2050 – so these retrofit vs. new build questions are already worth considering from a strategic point of view as the first blocks of the 2050 picture become known.

***UK aspects***

As a sub-set of the competitive international market, the assessment of relevant UK capabilities and activities will help to understand if there are any technology areas where the UK is particularly strong, and hence the UK could export its technologies and expertise abroad. This is also tied into the R&D and industrial activities ongoing internationally, and whether there would be space for R&D activities in the UK to capture some of the arising IP value, or develop new technology in “white space” as a new opportunity for development.

However, ETI have stated at this stage of the TESBIC project, the primary focus is not on UK value generation or export potential; rather it is on the potential to deploy technologies in the UK. We have therefore borne in mind the current mix of UK plants, and likely strict emissions constraints applying to the power sector in 2030 – 2050 when estimating what plants types and fuels are likely to be used at different points in the future, and what mix of plants should be available for nearer-term demonstration opportunities. For example, unabated fossil fuels are unlikely to be built or be able to operate if the power sector has to decarbonise by around 2030.

## **5 Assessment of technology combinations**

This section presents the detailed assessment for each of the biomass power and capture technology combinations, bringing together information from the individual component reviews, and highlighting the key benefits and risks of each of the combinations in turn. The principal purpose of this Section is to act as an evidence base for the recommendations made in Section 6.

The 28 combination assessments were reviewed internally to ensure a consistent approach has been taken between all the partners in their assessments. A full day workshop was held on 2<sup>nd</sup> June 2011 to present and debate all the combinations in turn, and draw out key advantages and disadvantages.

The following pages present a short description for each technology combination, with their key benefits and risks. Co-firing and dedicated biomass combinations assessments are given in pairs on the same page for ease of comparison.

**(1) Co-firing combustion, with post-combustion amine scrubbing**

<b>Description</b>	<ul style="list-style-type: none"> <li>Biomass is milled with coal into powder, then combusted together in a boiler. Heat is recovered by producing steam, which then drives a steam turbine to generate power. After gas clean-up steps, CO<sub>2</sub> is separated from the cooled flue gases using a solvent scrubbing cycle, with solvent regeneration capturing the CO<sub>2</sub></li> </ul>
<b>Pros</b>	<ul style="list-style-type: none"> <li>This combination integrates compatible components, and can be readily applied as a retrofit to existing coal power plants.</li> <li>There is <b>high level of activity</b> internationally, and a number of the planned coal combustion solvent scrubbing demonstrations will co-fire biomass: <b>TRL 7-8 in 2020</b></li> <li>There are a number of pulverised coal boilers co-firing biomass in the UK, and a demonstration of solvent scrubbing on a large coal power plant</li> <li>The development, feedstock and environmental issues are fairly modest –scrubbing tower scale-up and degradation issues expected to be overcome</li> <li>Impact of the capture system on <b>operational flexibility</b> of the boiler plant is expected to be modest</li> </ul>
<b>Cons</b>	<ul style="list-style-type: none"> <li>There is a significant <b>efficiency penalty</b> associated with the heating requirement for solvent stripping</li> <li>Possible environmental problems with solvent loss to the atmosphere (amine slip)</li> </ul>

**(2) Dedicated biomass combustion with post-combustion amine scrubbing**

<b>Description</b>	<ul style="list-style-type: none"> <li>Biomass chips are burnt in a dedicated biomass boiler. Heat is recovered by producing steam, which then drives a steam turbine to generate power. After gas clean-up steps, CO<sub>2</sub> is separated from the cooled flue gases using a solvent scrubbing cycle, with solvent regeneration capturing the CO<sub>2</sub></li> </ul>
<b>Pros</b>	<ul style="list-style-type: none"> <li>This combination integrates compatible components, and the application of solvent scrubbing to dedicated biomass boilers is a <b>modest step technically from coal</b>. The TRL could therefore be 6-7 in 2020</li> <li>Application possible over a <b>range of scales</b> of operation, although not yet known if amine scrubbing will be economically viable at small scales</li> <li>The UK has numerous biomass combustion power plants in planning, and hence capture could be readily applied as a retrofit to these biomass power plants</li> <li>As with co-firing, there are few development, feedstock, operational or environmental issues</li> </ul>
<b>Cons</b>	<ul style="list-style-type: none"> <li>There is a significant <b>efficiency penalty</b> associated with the heating requirement for solvent stripping</li> <li>Dedicated biomass plants without capture have <b>lower efficiencies</b> and higher costs than coal power plants, hence capture efficiency penalties are proportionally larger</li> <li>Component suppliers of MW-scale dedicated biomass boilers are large non-UK industrials</li> </ul>

**(3) Co-firing combustion, with post-combustion low temperature solid sorbents**

<b>Description</b>	<ul style="list-style-type: none"> <li>Biomass is milled with coal into powder, then combusted together in a boiler. Heat is recovered by producing steam, which then drives a steam turbine to generate power. After gas clean-up steps, CO<sub>2</sub> is separated from the cooled flue gases using low temperature solid sorbents, with sorbent regeneration capturing the CO<sub>2</sub></li> </ul>
<b>Pros</b>	<ul style="list-style-type: none"> <li>There are a number of pulverised coal boilers co-firing biomass in the UK. This combination can be readily applied as a retrofit to existing coal power plants</li> <li>CFB technology is already proven at scale</li> <li>Slightly <b>lower efficiency penalty</b> than solvent scrubbing: ~4-5% for capture + 3% compression</li> <li>There is <b>activity internationally</b>, with the US DOE funding research, and leading research also at Nottingham and Edinburgh</li> <li>Impact of the capture system on operational flexibility of the boiler plant is expected to be modest</li> </ul>
<b>Cons</b>	<ul style="list-style-type: none"> <li>Technology is still relatively <b>early stage (only TRL 5 by 2020)</b>, and little industrial interest in the UK</li> <li>May not achieve the required loading increases</li> <li>Potential for <b>poisoning</b> by SO<sub>2</sub>, H<sub>2</sub>O and O<sub>2</sub></li> <li>Sorbents <b>costs unknown</b>, and overall costs are very approximate</li> </ul>

**(4) Dedicated biomass combustion, with post-combustion low temperature solid sorbents**

<b>Description</b>	<ul style="list-style-type: none"> <li>Biomass chips are burnt in a dedicated biomass boiler. Heat is recovered by producing steam, which then drives a steam turbine to generate power. After gas clean-up steps, CO<sub>2</sub> is separated from the cooled flue gases using low temperature solid sorbents, with sorbent regeneration capturing the CO<sub>2</sub></li> </ul>
<b>Pros</b>	<ul style="list-style-type: none"> <li>This combination can be readily applied as a retrofit to biomass power plants</li> <li>CFB technology is already proven at scale</li> <li>Slightly <b>lower efficiency penalty</b> than solvent scrubbing: ~4-5% for capture + 3% compression, and possible capture rates above 90%</li> <li>The UK has numerous biomass combustion power plants in planning, and hence capture could be readily applied as a retrofit to these biomass power plants</li> <li>Impact of the capture system on operational flexibility of the boiler plant is expected to be modest</li> </ul>
<b>Cons</b>	<ul style="list-style-type: none"> <li>Researchers and industry are <b>only focusing on coal</b>, not dedicated biomass. Hence combination is likely to be too early stage (only TRL 4 by 2020)</li> <li>May not achieve the required loading increases</li> <li>Potential for <b>poisoning</b> by SO<sub>2</sub>, H<sub>2</sub>O and O<sub>2</sub></li> <li>Sorbents <b>costs unknown</b>, and overall costs are very approximate</li> </ul>

**(5) Co-firing combustion, with post-combustion ionic liquids**

<b>Description</b>	<ul style="list-style-type: none"> <li>Biomass is milled with coal into powder, then combusted together in a boiler. Heat is recovered by producing steam, which then drives a steam turbine to generate power. After gas clean-up steps, CO<sub>2</sub> is separated from the cooled flue gases using ionic liquids, with regeneration capturing the CO<sub>2</sub></li> </ul>
<b>Pros</b>	<ul style="list-style-type: none"> <li>There are a number of pulverised coal boilers co-firing biomass in the UK. This combination can be readily applied as a retrofit to existing coal power plants – potentially much smaller tower volumes required / <b>smaller footprint</b></li> <li>Could also be combined with amine functionality</li> <li>Potential for slightly <b>lower parasitic losses</b> than amine scrubbing</li> <li><b>Low material losses</b> from the process cycle, due to negligible vapour pressure and chemical stability of ILs</li> <li>IL salt compounds can be <b>optimised</b> for specific applications and flue gases</li> </ul>
<b>Cons</b>	<ul style="list-style-type: none"> <li>Technology is still <b>early stage</b> (currently TRL 2-3, only 4-5 by 2020)</li> <li>Susceptibility to <b>poisoning</b> by contaminants is unknown</li> <li>Some ILs have high viscosity when they absorb CO<sub>2</sub>, hence pumping energy could be significant</li> <li>Current IL <b>capital costs are extremely high</b> (\$1,000 – 10,000/kg)</li> </ul>

**(6) Dedicated biomass combustion, with post-combustion ionic liquids**

<b>Description</b>	<ul style="list-style-type: none"> <li>Biomass chips are burnt in a dedicated biomass boiler. Heat is recovered by producing steam, which then drives a steam turbine to generate power. After gas clean-up steps, CO<sub>2</sub> is separated from the cooled flue gases using ionic liquids, with sorbent regeneration capturing the CO<sub>2</sub></li> </ul>
<b>Pros</b>	<ul style="list-style-type: none"> <li>The UK has numerous biomass combustion power plants in planning. This combination can be applied as a retrofit to biomass power plants – potentially much smaller tower volumes required / <b>smaller footprint</b></li> <li>Could also be combined with amine functionality</li> <li>Potential for <b>slightly lower parasitic losses</b> than amine scrubbing</li> <li><b>Low material losses</b> from the process cycle, due to negligible vapour pressure and chemical stability of ILs</li> <li>IL salt compounds can be optimised for specific applications and flue gases</li> </ul>
<b>Cons</b>	<ul style="list-style-type: none"> <li>Technology is <b>too early stage</b> (currently TRL 1-2, only 3-4 by 2020)</li> <li>Susceptibility to <b>poisoning</b> by contaminants is unknown</li> <li>Some ILs have high viscosity when they absorb CO<sub>2</sub>, hence pumping energy could be significant</li> <li>Current IL <b>capital costs are extremely high</b> (\$1,000 – 10,000/kg)</li> </ul>

**(5a) Co-firing combustion, with post-combustion enzymes**

<b>Description</b>	<ul style="list-style-type: none"> <li>Biomass is milled with coal into powder, then combusted together in a boiler. Heat is recovered by producing steam, which then drives a steam turbine to generate power. After gas clean-up steps, CO<sub>2</sub> is separated from the cooled flue gases using a solvent cycle loaded with enzymes, with regeneration capturing the CO<sub>2</sub></li> </ul>
<b>Pros</b>	<ul style="list-style-type: none"> <li>There are a number of pulverised coal boilers co-firing biomass in the UK. This combination can be readily applied as a retrofit to existing coal power plants – potentially much smaller tower volumes required / <b>smaller footprint</b></li> <li>Enzymes enhance the CO<sub>2</sub> reaction rates of more commercially mature amine solvents</li> <li>Potential for <b>slightly lower parasitic losses</b> than amine scrubbing, and significantly reduced solvent volumes</li> </ul>
<b>Cons</b>	<ul style="list-style-type: none"> <li>Technology is still <b>early stage</b> (currently TRL 3, only 5 by 2020)</li> <li><b>Few international players</b>, and no UK capabilities</li> <li>Susceptibility to poisoning by contaminants is unknown, and high temperature <b>durability</b> is currently limited</li> <li>Current <b>enzymes capital costs are very uncertain</b>, and likely to be high</li> </ul>

**(6a) Dedicated biomass combustion, with post-combustion enzymes**

<b>Description</b>	<ul style="list-style-type: none"> <li>Biomass chips are burnt in a dedicated biomass boiler. Heat is recovered by producing steam, which then drives a steam turbine to generate power. After gas clean-up steps, CO<sub>2</sub> is separated from the cooled flue gases using a solvent cycle loaded with enzymes, with sorbent regeneration capturing the CO<sub>2</sub></li> </ul>
<b>Pros</b>	<ul style="list-style-type: none"> <li>The UK has numerous biomass combustion power plants in planning. This combination can be applied as a retrofit to biomass power plants</li> <li>Enzymes enhance the CO<sub>2</sub> reaction rates of more commercially mature amine solvents</li> <li>Potential for slightly lower parasitic losses than amine scrubbing, and significantly reduced solvent volumes / tower sizes</li> </ul>
<b>Cons</b>	<ul style="list-style-type: none"> <li>Technology is too <b>early stage</b> (currently TRL 2, only 4 by 2020), since main target is capture from coal plants</li> <li><b>Few international players</b>, and no UK capabilities</li> <li>Susceptibility to poisoning by contaminants is unknown, and high temperature <b>durability</b> is currently limited</li> <li>Current <b>enzymes capital costs are very uncertain</b>, and likely to be high</li> </ul>



**(7) Co-firing combustion, with post-combustion CO<sub>2</sub> membrane separation**

<b>Description</b>	<ul style="list-style-type: none"> <li>Biomass is milled with coal into powder, then combusted together in a boiler. Heat is recovered by producing steam, which then drives a steam turbine to generate power. After gas clean-up steps, CO<sub>2</sub> is separated from the cooled flue gases using a pressure difference across a CO<sub>2</sub>-selective membrane</li> </ul>
<b>Pros</b>	<ul style="list-style-type: none"> <li>There are a number of pulverised coal boilers co-firing biomass in the UK. This combination can be readily applied as a retrofit to existing coal power plants</li> <li>Operationally <b>simple approach</b>, small footprint</li> <li>Could also be combined with amines if using membrane gas absorption</li> <li>Research at Imperial and Newcastle, only a few other groups internationally</li> </ul>
<b>Cons</b>	<ul style="list-style-type: none"> <li>Achieving sufficiently high selectivity with good CO<sub>2</sub> permeability is a significant technical hurdle, especially if large flow-rates are required</li> <li>The need for elevated pressures or for a vacuum to provide a driving force for the CO<sub>2</sub> to pass through the membrane imposes a large <b>energy penalty</b></li> <li>Potential for <b>fouling</b> of the membrane with flue gas components</li> <li>Membrane <b>material stability</b> at high operating temperatures is unknown</li> <li>Technology is still <b>early stage</b>, seen as likely to take a back seat to the development of advanced amine solvents, and at best, see commercialisation in tandem with solid sorbent technologies (TRL 5 by 2020)</li> </ul>

**(8) Dedicated biomass combustion, with post-combustion CO<sub>2</sub> membrane separation**

<b>Description</b>	<ul style="list-style-type: none"> <li>Biomass chips are burnt in a dedicated biomass boiler. Heat is recovered by producing steam, which then drives a steam turbine to generate power. After gas clean-up steps, CO<sub>2</sub> is separated from the cooled flue gases using a pressure difference across a CO<sub>2</sub>-selective membrane</li> </ul>
<b>Pros</b>	<ul style="list-style-type: none"> <li>The UK has numerous biomass combustion power plants in planning. This combination can be applied as a retrofit to biomass power plants</li> <li>Operationally <b>simple approach</b>, small footprint</li> <li>Could also be combined with amines if using membrane gas absorption</li> <li>Research at Imperial and Newcastle, only a few other groups internationally</li> </ul>
<b>Cons</b>	<ul style="list-style-type: none"> <li>Achieving sufficiently high selectivity with good CO<sub>2</sub> permeability is a significant technical hurdle, especially if large flow-rates are required</li> <li>Performance is highly dependent on the flue gas CO<sub>2</sub> concentration, and dedicated biomass flue gas CO<sub>2</sub> concentrations will be lower than co-firing with coal</li> <li>The need for elevated pressures or for a vacuum to provide a driving force for the CO<sub>2</sub> to pass through the membrane imposes a large <b>energy penalty</b></li> <li>Potential for <b>fouling</b> of the membrane with flue gas components</li> <li>Membrane <b>material stability</b> at high operating temperatures is unknown</li> <li>Researchers and industry are focusing on coal, not dedicated biomass. Hence combination is likely to be too <b>early stage</b> (only TRL 4 by 2020)</li> </ul>

**(9) Co-firing combustion, with post-combustion carbonate looping**

<b>Description</b>	<ul style="list-style-type: none"> <li>Biomass is milled with coal into powder, then combusted together in a boiler. Heat is recovered by producing steam, which then drives a steam turbine to generate power. After gas clean-up steps, CO<sub>2</sub> in the flue gas reacts with CaO in the carbonator to form solid CaCO<sub>3</sub>. This CaCO<sub>3</sub> is then transferred to the calciner, where heat is supplied (by additional fuel CFB combustion with pure O<sub>2</sub>) to release a stream of CO<sub>2</sub> for capture</li> </ul>
<b>Pros</b>	<ul style="list-style-type: none"> <li>Extremely cheap and widely available sorbent (crushed limestone)</li> <li><b>Repowers system</b>, offsetting most of the additional capture capex – up to 40 % more power generated, hence one of the very cheapest capture technologies</li> <li>Potentially <b>lowest efficiency penalty</b> of all the post-combustion capture systems, due to high temperature heat recovery in the carbonator</li> <li>Strong <b>synergy with cement manufacture</b>, and potential for significant cement decarbonisation, using the purge stream of CaO</li> <li>Given pilot plant and industrial activities, TRL is likely to reach 5-6 in 2020</li> </ul>
<b>Cons</b>	<ul style="list-style-type: none"> <li>CFB combustion is not widely used for coal, and not used in the UK</li> <li>Cement integration not fully proven</li> <li><b>Degradation</b> leads to a large <b>purge of CaO</b> needs disposal unless integrated with cement manufacture</li> <li>More complex than standard post-combustion capture</li> <li>Biomass utilisation in the calciner may not be possible, i.e. maximum 70% co-firing</li> </ul>

**(10) Dedicated biomass combustion, with post-combustion carbonate looping**

<b>Description</b>	<ul style="list-style-type: none"> <li>Biomass chips are burnt in a dedicated biomass boiler. Heat is recovered by producing steam, which then drives a steam turbine to generate power. After gas clean-up steps, CO<sub>2</sub> in the flue gas reacts with CaO in the carbonator to form solid CaCO<sub>3</sub>, and also generate extra heat. This CaCO<sub>3</sub> is then transferred to the calciner, where heat is supplied (by additional fuel CFB combustion with pure O<sub>2</sub>) to release a stream of CO<sub>2</sub> for capture</li> </ul>
<b>Pros</b>	<ul style="list-style-type: none"> <li>Extremely cheap and widely available sorbent (crushed limestone)</li> <li><b>Repowers system</b> (40% more power), offsetting most of the additional capture capex and effort to modify the steam cycle – hence very cheap capture</li> <li>Potentially <b>lowest efficiency penalty</b> (~3% + 3%) of all the post-combustion capture systems, due to high temperature heat recovery in the carbonator</li> <li>Strong <b>synergy with cement manufacture</b>, and potential for significant cement decarbonisation, using the purge stream of CaO</li> <li>Highly suitable for small-scale applications, due to fluidised bed reactors</li> </ul>
<b>Cons</b>	<ul style="list-style-type: none"> <li><b>Biomass utilisation in the calciner may not be possible</b> (due to tars &amp; coking). Coal is more of a focus than dedicated biomass, hence TRL may only be 4-5 by 2020</li> <li>CFB combustion is not widely used in UK yet, though very widely used elsewhere</li> <li><b>Degradation</b> leads to a large <b>purge of CaO</b> needing disposal, unless integrated with cement manufacture (not yet proven), although less of a problem for small-scales</li> <li>More complex than standard post-combustion capture</li> </ul>

**(11) Co-firing oxy-combustion, with cryogenic O<sub>2</sub> separation**

<b>Description</b>	<ul style="list-style-type: none"> <li>Biomass is milled with coal into powder, then combusted together in a boiler. The boiler is fitted with a cryogenic oxygen plant, and modified to combust fuel in a mixture of pure O<sub>2</sub> and recycled flue gas (to regulate combustion temperatures), rather than in air. The cleaned flue gas therefore comprises mainly CO<sub>2</sub> and water, rather than N<sub>2</sub> and CO<sub>2</sub>, facilitating downstream CO<sub>2</sub> capture. Heat recovery produces steam for a turbine to generate power as for a standard combustion plant</li> </ul>
<b>Pros</b>	<ul style="list-style-type: none"> <li>The combination integrates compatible components, and can be readily applied as a retrofit to existing coal power plants</li> <li>There is a <b>high level of activity</b> internationally, and a number of the demonstrations after 2015 may co-fire biomass. Likely <b>TRL is 7 in 2020</b></li> <li>Few development or environmental issues</li> </ul>
<b>Cons</b>	<ul style="list-style-type: none"> <li>Currently, cryogenic O<sub>2</sub> separation is the main commercially available technology for O<sub>2</sub> production, but there is a significant <b>efficiency penalty</b></li> <li>The integration of a cryogenic ASU into the plant results in complex operation, slow response and start-up times – resulting in a significantly <b>less flexible plant</b></li> <li><b>Corrosion mechanisms</b> are intensified due to higher concentrations of certain species via recycling, but this is expected to be overcome</li> </ul>

**(12) Dedicated biomass oxy-combustion, with cryogenic O<sub>2</sub> separation**

<b>Description</b>	<ul style="list-style-type: none"> <li>Biomass is burnt in a dedicated biomass boiler, fitted with a cryogenic oxygen plant, and modified to operate in oxy-fuel mode (as described before)</li> </ul>
<b>Pros</b>	<ul style="list-style-type: none"> <li>The combination integrates compatible components, and is only a <b>modest step technically from coal</b> – likely TRL is 6 in 2020</li> <li>Application is possible over a range of scales of operation</li> <li>The UK has numerous biomass combustion power plants in planning, and hence capture could be readily <b>applied as a retrofit</b> to these new biomass power plants</li> </ul>
<b>Cons</b>	<ul style="list-style-type: none"> <li>There are currently no known projects which are specifically aimed at the combination of oxy-fuel firing with dedicated biomass combustion, and there is also limited experience with coal CFB oxy-combustion in comparison to pulverised coal boilers</li> <li>100% biomass oxy-fuel firing may give boiler tube <b>corrosion issues</b>, due to species concentration with recycling, so biomass quality may have to be tightly specified</li> <li>Currently, cryogenic O<sub>2</sub> separation is the main commercially available technology for O<sub>2</sub> production, but there is a significant <b>efficiency penalty</b></li> <li>The integration of a cryogenic ASU into the plant results in complex operation, slow response and start-up times – resulting in a significantly <b>less flexible plant</b></li> </ul>

**(11a) Co-firing oxy-combustion, with membrane O<sub>2</sub> separation**

<b>Description</b>	<ul style="list-style-type: none"> <li>Biomass is milled with coal into powder, then combusted together in a boiler. The boiler is fitted with a membrane oxygen plant, and modified to combust fuel in a mixture of pure O<sub>2</sub> and recycled flue gas (to regulate combustion temperatures), rather than in air. The cleaned flue gas therefore comprises mainly CO<sub>2</sub> and water, rather than N<sub>2</sub> and CO<sub>2</sub>, facilitating downstream CO<sub>2</sub> capture. Heat recovery produces steam for a turbine to generate power as for a standard combustion plant</li> </ul>
<b>Pros</b>	<ul style="list-style-type: none"> <li>The combination can be readily applied as a retrofit to existing coal power plants</li> <li>There is a high level of activity in oxy-fuel internationally, and a number of the demonstrations after 2015 may co-fire biomass</li> <li>Several <b>major industrials</b> developing O<sub>2</sub> membranes</li> <li>Potential for <b>significant modest step technically from coal</b> in O<sub>2</sub> production by using membranes instead of cryogenic ASU</li> </ul>
<b>Cons</b>	<ul style="list-style-type: none"> <li>Currently, membrane O<sub>2</sub> separation is only at the lab/pilot scale (TRL 4), but could reach TRL 6 by 2020</li> <li>Membrane development issues include capacity, <b>stability</b>, operating temperature, and <b>plugging</b> - durability and increased contaminant tolerance are required</li> <li>The heat integration of a membrane oxygen separation into the plant results in complex operation, slow response and start-up times – <b>poor flexibility</b> expected</li> <li><b>Corrosion mechanisms</b> are intensified due to higher concentrations of certain species via recycling, but this is expected to be overcome</li> </ul>

**(12a) Dedicated biomass oxy-combustion, with membrane O<sub>2</sub> separation**

<b>Description</b>	<ul style="list-style-type: none"> <li>Biomass is burnt in a dedicated biomass boiler, fitted with a membrane oxygen plant, and modified to operate in oxy-fuel mode (as described before)</li> </ul>
<b>Pros</b>	<ul style="list-style-type: none"> <li>Application is possible over a range of scales of operation</li> <li>The UK has numerous biomass combustion power plants in planning, and hence oxy-fuel capture could be readily applied as a retrofit to these new biomass power plants – likely TRL of around 5 by 2020</li> <li>Several major industrials developing O<sub>2</sub> membranes</li> <li>Potential for <b>significant energy and costs improvements</b> in O<sub>2</sub> production by using membranes instead of cryogenic ASU</li> </ul>
<b>Cons</b>	<ul style="list-style-type: none"> <li>There are currently no known projects which are specifically aimed at the combination of oxy-fuel firing with dedicated biomass combustion, and there is also limited experience with coal CFB oxy-combustion in comparison to pulverised coal boilers</li> <li>100% biomass oxy-fuel firing may give boiler tube <b>corrosion issues</b>, due to species concentration with recycling, so biomass quality may have to be tightly specified</li> <li>Currently, membrane O<sub>2</sub> separation is only at the lab/pilot scale (TRL 4), but could reach TRL 6 by 2020</li> <li>Membrane development issues include capacity, <b>stability</b>, operating temperature, and <b>plugging</b> - durability and increased contaminant tolerance are required</li> <li>The heat integration of a membrane oxygen separation into the plant results in complex operation, slow response and start-up times – <b>poor flexibility</b> expected</li> </ul>

**(13) Co-firing chemical-looping-combustion using solid oxygen carriers**

<b>Description</b>	<ul style="list-style-type: none"> <li>Syngas is combusted in a fluidised bed by a metal oxide, forming CO<sub>2</sub> and H<sub>2</sub>O; condensation of H<sub>2</sub>O provides capture-ready CO<sub>2</sub> stream. Metal oxide is oxidised in air reactor in a highly exothermic reaction. Ground biomass and coal mixture may be gasified using steam / CO<sub>2</sub> either within (in-situ) or prior to the fuel reactor</li> </ul>
<b>Pros</b>	<ul style="list-style-type: none"> <li><b>Minimal plant efficiency penalty</b>, and potential for significantly increased efficiency if operating at pressure, by passing hot reduced air through a <b>gas turbine</b>. Alternatively, partial re-oxidation with steam in the oxidisation reactor can <b>produce H<sub>2</sub></b></li> <li>In-situ gasification leads to improved reaction dynamics, and avoids the additional capex of a separate gasification reactor</li> <li>Research strengths at Cambridge and Imperial</li> </ul>
<b>Cons</b>	<ul style="list-style-type: none"> <li>There is limited (but increasing) industrial interest in CLC to date. Current TRL of 4 is relatively low, and UK experience is only at currently at lab-scale. However, the TRL is likely to reach 5-6 by 2020 based on the planned pilot projects going ahead</li> <li><b>Coal gasification much slower</b> redox reactions, hence dedicated biomass or high biomass co-firing is the preferred option</li> <li>Unreacted coal char carried over into the oxidisation reactor, hence CO<sub>2</sub> will be lost from the system (lower capture rates than when using biomass)</li> <li>Retrofit to a pulverised coal boiler is impractical, new build only</li> <li>Slow <b>loss of activity</b> through cycling, possible alkali contamination of metal oxides</li> </ul>

**(14) Dedicated biomass chemical-looping-combustion using solid oxygen carriers**

<b>Description</b>	<ul style="list-style-type: none"> <li>Syngas is combusted in a fluidised bed by a metal oxide, forming CO<sub>2</sub> and H<sub>2</sub>O; condensation of H<sub>2</sub>O provides capture-ready CO<sub>2</sub> stream. Metal oxide is oxidised in air reactor in a highly exothermic reaction. Feedstock may be gasified using steam / CO<sub>2</sub> either within (in-situ) or prior to the fuel reactor</li> </ul>
<b>Pros</b>	<ul style="list-style-type: none"> <li><b>Very high CO<sub>2</sub> capture</b> rates are possible, since the amount of unreacted biomass char will be small, so there will be little carry-over into the oxidisation reactor</li> <li><b>Minimal plant efficiency penalty</b>, and potential for significantly increased efficiency if operating at pressure, by passing hot reduced air through a gas turbine. Alternatively, partial re-oxidation with steam in the oxidisation reactor can <b>produce H<sub>2</sub></b></li> <li><b>Highly suitable for small-scale</b> power applications, or the use of H<sub>2</sub> in fuel cells</li> <li>In-situ gasification leads to improved reaction dynamics, and avoids the additional capex of a separate gasification reactor. <b>Biomass reactions faster</b> than coal, hence little unreacted char is carried over into the oxidisation reactor</li> <li>Retrofit to a dedicated biomass CFB boiler should be possible (since the technology is similar to a dual fluidised bed gasifier)</li> </ul>
<b>Cons</b>	<ul style="list-style-type: none"> <li>There is limited (but increasing) industrial interest in CLC to date. Current TRL of 4 is relatively low, and UK experience is only at lab-scale. However, the TRL is likely to reach 5 – 6 by 2020</li> <li>Slow <b>loss of activity</b> through cycling, possible alkali contamination of metal oxides</li> </ul>

**(15) Co-firing IGCC with physical absorption**

<b>Description</b>	<ul style="list-style-type: none"> <li>Coal and biomass are ground into a slurry, and gasified at high pressure in pure O<sub>2</sub>. Resulting syngas is cleaned, before water-gas-shift concentrates CO<sub>2</sub> for removal by physical absorption in solvents (regenerative cycle). Remaining H<sub>2</sub> then combusted in a modified gas turbine, with a steam turbine combined cycle also generating power</li> </ul>
<b>Pros</b>	<ul style="list-style-type: none"> <li>This combination integrates commercially mature and compatible components</li> <li><b>High level of activity</b> internationally – several of the announced coal IGCC-CCS demonstrations online after 2015 will co-fire biomass. <b>Likely TRL 7 in 2020</b></li> <li><b>Efficiency with capture is high</b>, and could be even higher if the latest gas turbine developments are incorporated</li> <li>Few development, feedstock or environmental issues</li> </ul>
<b>Cons</b>	<ul style="list-style-type: none"> <li>Complex operation, slow response and start-up – unlikely to peak load follow unless using H<sub>2</sub> buffer storage</li> <li>Substantial gas turbine modifications needed if retrofitting capture</li> <li>No IGCC plants currently built in the UK, although 3 of the 7 UK applicants to the NER300 CCS competition will use IGCC, and could be online after 2015</li> <li>Only value add in demonstration is integration learning at scale, but this requires £bn's</li> </ul>

**(16) Dedicated biomass IGCC with physical absorption**

<b>Description</b>	<ul style="list-style-type: none"> <li>Biomass chips are gasified at high pressure in pure O<sub>2</sub> in a fluidised bed. Resulting syngas is cleaned, before water-gas-shift concentrates CO<sub>2</sub> for removal by physical absorption in solvents (regenerative cycle). H<sub>2</sub> then combusted in a modified gas turbine, with a steam turbine combined cycle also generating power</li> </ul>
<b>Pros</b>	<ul style="list-style-type: none"> <li>Physical solvent absorption is mature</li> <li>Numerous spill-over learning effects from coal IGCC with capture, hence likely TRL 5 to 6 in 2020</li> <li>Few feedstock or environmental issues: no technical show-stoppers</li> <li><b>High efficiencies with capture</b> for small-scale biomass if the latest gas turbine developments are incorporated</li> </ul>
<b>Cons</b>	<ul style="list-style-type: none"> <li><b>Minimal activity</b> internationally – combination only explored theoretically</li> <li><b>BIGCC not yet commercial</b> – only current projects are in the US, using a Dual gasifier which would have 50% carbon losses if used for capture</li> <li>Substantial gas turbine modifications needed if retrofitting capture</li> <li>Complex operation, slow response and start-up – unlikely to peak load follow unless using H<sub>2</sub> buffer storage</li> <li>No BIGCC plants in the UK, also currently no coal IGCC plants, or large biomass gasifiers</li> </ul>

**(17) Co-firing IGCC with H<sub>2</sub> membrane separation**

<b>Description</b>	<ul style="list-style-type: none"> <li>Coal and biomass are ground into a slurry, and gasified at high pressure in pure O<sub>2</sub>. Resulting syngas is cleaned, before WGS concentrates H<sub>2</sub> and CO<sub>2</sub>. Selective membrane filters H<sub>2</sub> for combustion in a modified gas turbine, with a steam turbine combined cycle also generating power. CO<sub>2</sub> purified before compression</li> <li>Future concepts integrate WGS with H<sub>2</sub> membrane separation</li> </ul>
<b>Pros</b>	<ul style="list-style-type: none"> <li>Compared to standard IGCC-CCS, possible <b>efficiency improvement of 1-3%</b> points</li> <li>Estimated 0 - 15% <b>reduction in capital costs</b> in the future</li> <li>Adding a H<sub>2</sub> membrane has less impact on plant flexibility than solvent absorption</li> </ul>
<b>Cons</b>	<ul style="list-style-type: none"> <li>H<sub>2</sub> membrane <b>early stage</b> (TRL 2-3) currently, but lack of real-world syngas experience</li> <li>No demonstration of combined system yet, and US future plans might not co-fire.</li> <li>Sensitive to <b>contaminants</b> and <b>fouling</b>, and stability issues</li> <li>Selectivity of single membrane currently limited to only 65-80%, need multiple stages (which adds to cost)</li> <li>Complex operation, slow response and start-up – unlikely to peak load follow unless using H<sub>2</sub> buffer storage</li> <li>Substantial gas turbine modifications needed if retrofitting capture</li> <li>No IGCC plants built in the UK</li> </ul>

**(18) Dedicated biomass IGCC with H<sub>2</sub> membrane separation**

<b>Description</b>	<ul style="list-style-type: none"> <li>Biomass chips are gasified at high pressure in pure O<sub>2</sub> in a fluidised bed. WGS concentrates H<sub>2</sub> and CO<sub>2</sub>. Selective membrane filters H<sub>2</sub> for combustion in a modified gas turbine, with a steam turbine combined cycle also generating power.</li> <li>Future concepts integrate WGS with H<sub>2</sub> membrane separation</li> </ul>
<b>Pros</b>	<ul style="list-style-type: none"> <li>Possible <b>efficiency improvement of 1-3%</b> points relative to standard BIGCC-CCS</li> <li>Estimated 0 - 15% <b>reduction in capital costs</b> in the future</li> <li>Adding a H<sub>2</sub> membrane has less impact on plant flexibility than solvent absorption</li> </ul>
<b>Cons</b>	<ul style="list-style-type: none"> <li>Combined system not even considered theoretically yet</li> <li>H<sub>2</sub> membrane <b>early stage</b> (TRL 2-3) currently, but lack of real-world syngas experience</li> <li>Sensitive to <b>contaminants</b> and <b>fouling</b>, and stability issues</li> <li>Selectivity of single membrane currently limited to only 65-80%, need multiple stages (which adds to cost)</li> <li><b>BIGCC not yet commercial</b> – only current projects are in the US, using a Dual gasifier, which would have 50% carbon losses with capture</li> <li>Complex operation, slow response and start-up – unlikely to peak load follow unless using H<sub>2</sub> buffer storage</li> <li>Substantial gas turbine modifications needed if retrofitting capture</li> <li>No BIGCC plants in the UK, also no coal IGCC plants, or large biomass gasifiers</li> </ul>

**(19) Co-firing IGCC with syngas membrane generation**

<p><b>Description</b></p>	<ul style="list-style-type: none"> <li>• Ion Transfer Membrane (ITM) is integrated inside the gasifier. O<sub>2</sub> is depleted in the permeate side by partial oxidation of coal, biomass or natural gas, driving the O<sub>2</sub> partial pressure difference and avoiding any energy consumption – achieves 100% O<sub>2</sub> selectivity from hot air side</li> <li>• Rest of the plant downstream is the same as other IGCC configurations</li> </ul>
<p><b>Pros</b></p>	<ul style="list-style-type: none"> <li>• Compared to standard IGCC-CCS, possible <b>efficiency improvement of 5-6 %-points</b></li> <li>• Potential of rapid start-up and <b>higher flexibility</b> relatively to standard IGCC-CCS</li> <li>• <b>Big players</b> active, e.g. Air Liquide, Praxair and Air Products helped by DoE and EPRI</li> </ul>
<p><b>Cons</b></p>	<ul style="list-style-type: none"> <li>• No co-firing ITM plants exist – <b>current TRL is only 2-3</b>. Only 1 planned pilot with coal in Utah University, US, hence likely TRL of 5 in 2020</li> <li>• <b>Membrane plugging</b> with dust or ash fusion, and <b>durability</b> at high temperature – these are both key showstoppers</li> <li>• Substantial gas turbine modifications needed if retrofitting downstream capture, and need to replace the whole gasifier with the new upstream membrane reactor</li> <li>• No IGCC plants built in the UK, and only UK work on natural gas ITM, not coal</li> </ul>

**(20) Dedicated biomass IGCC with syngas membrane generation**

<p><b>Description</b></p>	<ul style="list-style-type: none"> <li>• Ion Transfer Membrane (ITM) is integrated inside the gasifier. O<sub>2</sub> is depleted in the permeate side by partial oxidation of coal, biomass or natural gas, driving the O<sub>2</sub> partial pressure difference and avoiding any energy consumption – achieves 100% O<sub>2</sub> selectivity from hot air side</li> <li>• Rest of the plant downstream is the same as other BIGCC configurations</li> </ul>
<p><b>Pros</b></p>	<ul style="list-style-type: none"> <li>• Compared to standard BIGCC-CCS, possible <b>efficiency improvement of 5-6 %-points</b></li> <li>• Potential of rapid start-up and <b>higher flexibility</b> relatively to standard BIGCC-CCS</li> <li>• <b>Big players</b> active, e.g. Air Liquide, Praxair and Air Products helped by DoE and EPRI</li> </ul>
<p><b>Cons</b></p>	<ul style="list-style-type: none"> <li>• Combined system not even considered theoretically yet</li> <li>• ITM-syngas only at <b>TRL 2-3</b>, only 1 planned pilot with coal in Utah University, US.</li> <li>• <b>Membrane plugging</b> with dust or ash fusion, and <b>durability</b> at high temperature - these are both key showstoppers</li> <li>• <b>BIGCC not yet commercial</b> – only current projects are in the US, using a Dual gasifier, which would have 50% carbon losses with capture</li> <li>• Complex operation, slow response and start-up – unlikely to peak load follow unless using H<sub>2</sub> buffer storage</li> <li>• Substantial gas turbine modifications needed if retrofitting capture, and need to replace the whole gasifier with the new upstream membrane reactor</li> <li>• No BIGCC plants in the UK, also no coal IGCC plants, or large biomass gasifiers</li> </ul>



**(21) Co-firing sorbent enhanced reforming**

<b>Description</b>	<ul style="list-style-type: none"> <li>Coal and biomass gasified in H<sub>2</sub>O and pure O<sub>2</sub>, to produce CH<sub>4</sub>-rich syngas. After gas cleaning, then reforming, water-gas shift and carbonation of CaO are all integrated in a single step, producing H<sub>2</sub> for gas turbines or fuel cell power generation. This forms solid CaCO<sub>3</sub>, which is then transferred to the calciner, where heat is supplied (by additional fuel CFB combustion with pure O<sub>2</sub>) to release CO<sub>2</sub> for capture</li> </ul>
<b>Pros</b>	<ul style="list-style-type: none"> <li>There are <b>potential capital cost savings</b> by integrating several major steps</li> <li><b>Very high plant efficiencies</b> could be possible, dependent on assumption regarding sorbent stability and power production by fuel cell or gas turbine combined cycle</li> <li>Sorbent derived from cheap and environmentally benign limestone</li> <li>UK expertise, due to spill-over from sorbent development (calcium looping)</li> </ul>
<b>Cons</b>	<ul style="list-style-type: none"> <li><b>Technical complexity</b> is high. SER only demonstrated at lab-scale in fixed and fluidised beds, but not using biosyngas, hence only likely to reach TRL 4-5 in 2020</li> <li>Process efficiency is undermined by <b>decay in sorbent reactivity</b> which may be exaggerated by gas impurities or direct contact with fuel in the calciner</li> <li>A reforming catalyst is needed to shift the chemical equilibrium – still under development, and sensitive to <b>poisoning</b></li> <li>Temperature-swing regeneration needs a heat input without diluting CO<sub>2</sub> stream, whereas pressure-swing regeneration moves solids across a pressure gradient</li> <li><b>Coal gasification rates are slow</b>, biomass char reactivity preferred</li> </ul>

**(22) Dedicate biomass sorbent enhanced reforming**

<b>Description</b>	<ul style="list-style-type: none"> <li>Biomass gasified in H<sub>2</sub>O and pure O<sub>2</sub>, to produce CH<sub>4</sub>-rich syngas. After gas cleaning, then reforming, water-gas shift and carbonation of CaO are all integrated in a single step, producing H<sub>2</sub> for gas turbines or fuel cell power generation. This forms solid CaCO<sub>3</sub>, which is then transferred to the calciner, where heat is supplied (by additional fuel CFB combustion with pure O<sub>2</sub>) to release CO<sub>2</sub> for capture</li> </ul>
<b>Pros</b>	<ul style="list-style-type: none"> <li>There are <b>potential capital cost savings</b> by integrating several major steps</li> <li><b>Very high plant efficiencies</b> could be possible, dependent on assumption regarding sorbent stability and power production by fuel cell or gas turbine combined cycle</li> <li>Sorbent derived from cheap and environmentally benign limestone</li> <li>UK expertise, due to spill-over from sorbent development (calcium looping)</li> <li>Suitable for small-scale power production</li> <li>Biomass char reactivity is high, hence reaction rates are high compared to coal</li> </ul>
<b>Cons</b>	<ul style="list-style-type: none"> <li><b>Technical complexity</b> is high. SER only demonstrated at lab-scale in fixed and fluidised beds, but not using biosyngas, hence only likely to reach TRL 4-5 in 2020</li> <li>Process efficiency is undermined by <b>decay in sorbent reactivity</b> which may be exaggerated by gas impurities or direct contact with fuel in the calciner</li> <li>A reforming catalyst is needed to shift the chemical equilibrium – still under development, and sensitive to <b>poisoning</b></li> <li>Temperature-swing regeneration needs a heat input without diluting CO<sub>2</sub> stream, whereas pressure-swing regeneration moves solids across a pressure gradient</li> </ul>

**(23) ZECA concept with co-firing**

<b>Description</b>	<ul style="list-style-type: none"> <li>Biomass and coal gasified in high-pressure H<sub>2</sub>, to produce CH<sub>4</sub>. After gas cleaning, then reforming, water-gas shift and carbonation of CaO are all integrated in a single step, producing H<sub>2</sub> for the gasifier, and gas turbine or SOFC power generation. This forms solid CaCO<sub>3</sub>, which is then transferred to the calciner, where heat is supplied (by additional fuel CFB combustion with pure O<sub>2</sub>) to release CO<sub>2</sub> for capture</li> </ul>
<b>Pros</b>	<ul style="list-style-type: none"> <li>There are <b>potential capital cost savings</b> by integrating several major steps</li> <li><b>Very high plant efficiencies</b> could be possible, dependent on assumption regarding sorbent stability and power production by fuel cell or gas turbine combined cycle</li> <li>Sorbent derived from cheap and environmentally benign limestone</li> <li>UK expertise, due to spill-over from sorbent development (calcium looping)</li> </ul>
<b>Cons</b>	<ul style="list-style-type: none"> <li><b>Technical complexity</b> is high (especially H<sub>2</sub> gasification at 70 bar) – effectively bolting 4 unproven technologies together... only likely to reach TRL 4 in 2020</li> <li>Process efficiency is undermined by <b>decay in sorbent reactivity</b> which may be exaggerated by gas impurities or direct contact with fuel in the calciner</li> <li>A reforming catalyst is needed to shift the chemical equilibrium – still under development, and sensitive to <b>poisoning</b></li> <li>Temperature-swing regeneration needs a heat input without diluting CO<sub>2</sub> stream, whereas pressure-swing regeneration moves solids across a pressure gradient</li> <li><b>Coal gasification rates are slow</b>, biomass char reactivity preferred</li> </ul>

**(24) ZECA concept with dedicated biomass**

<b>Description</b>	<ul style="list-style-type: none"> <li>Biomass gasified in high-pressure H<sub>2</sub>, to produce CH<sub>4</sub>. After gas cleaning, then reforming, water-gas shift and carbonation of CaO are all integrated in a single step, producing H<sub>2</sub> for the gasifier, and gas turbine or SOFC power generation. This forms solid CaCO<sub>3</sub>, which is then transferred to the calciner, where heat is supplied (by additional fuel CFB combustion with pure O<sub>2</sub>) to release CO<sub>2</sub> for capture</li> </ul>
<b>Pros</b>	<ul style="list-style-type: none"> <li>There are <b>potential capital cost savings</b> by integrating several major steps</li> <li><b>Very high plant efficiencies</b> could be possible, dependent on assumption regarding sorbent stability and power production by fuel cell or gas turbine combined cycle</li> <li>Sorbent derived from cheap and environmentally benign limestone</li> <li>UK expertise, due to spill-over from sorbent development (calcium looping)</li> <li>Suitable for small-scale power production</li> <li>Biomass char reactivity is high, hence reaction rates are high compared to coal</li> </ul>
<b>Cons</b>	<ul style="list-style-type: none"> <li><b>Technical complexity</b> is high (especially H<sub>2</sub> gasification at 70 bar) – effectively bolting 4 unproven technologies together... only likely to reach TRL 4 in 2020</li> <li>Process efficiency is undermined by <b>decay in sorbent reactivity</b> which may be exaggerated by gas impurities or direct contact with fuel in the calciner</li> <li>A reforming catalyst is needed to shift the chemical equilibrium – still under development, and sensitive to <b>poisoning</b></li> <li>Temperature-swing regeneration needs a heat input without diluting CO<sub>2</sub> stream, whereas pressure-swing regeneration moves solids across a pressure gradient</li> </ul>

## 6 Recommendations

Based on the benefits and risks of each technology combination, as presented in Section 5, this section describes the process followed in making our recommendations for D1.2, and discusses the shortlist of technology combinations to be taken forward (including at least one combination suitable for small-scale applications). The key criteria for these shortlisted technology combinations are also compared side-by-side in a summary matrix.

### 6.1 Combinations rejected

Based on the key advantages and disadvantages agreed during the full day workshop (held on 2<sup>nd</sup> June 2011), the TESBIC consortium then went through each combination in turn to agree whether there were strong enough reasons to reject the combination, and provided evidence for these rejections. In summary, 20 of the technology combinations have not been recommended for progression. The main reasons are given in Section 5, and summarised below:

- Low-temperature solid sorbents, ionic liquids, enzymes and membrane CO<sub>2</sub> separation combinations (**3, 4, 5, 6, 5a, 6a, 7, 8**) potentially have reduced capital costs compared to amine scrubbing, but they generally only have marginal efficiency benefits, and there are uncertainties regarding operating costs, as well as several technical issues yet to be resolved, for example:
  - Potential for poisoning of low-temperature solid sorbents by SO<sub>2</sub>, H<sub>2</sub>O and O<sub>2</sub>
  - Unknown contaminant behaviour, high current costs and viscosity for ionic liquids
  - Durability issues for enzymes at temperatures above only 40°C
  - Pressure differential and fouling issues for CO<sub>2</sub> membrane separation
- Membrane O<sub>2</sub> separation, membrane H<sub>2</sub> separation, membrane production of syngas, sorbent enhanced reforming and the ZECA concept combinations (**11a, 12a, 17, 18, 19, 20, 21, 22, 23, 24**) potentially have high plant electrical efficiencies. However, there are numerous technical showstoppers, in addition to uncertain capital costs, for example:
  - Doubts regarding the capacity and stability at high operating temperatures for O<sub>2</sub> membranes
  - Poor selectivity, dust fouling, and high pressure differences required for H<sub>2</sub> membranes
  - Durability and contaminant tolerance of membranes used to directly generate syngas
  - Sorbent decay, and reforming catalyst poisoning of sorbent-enhanced reforming
  - Zero Emission Coal Alliance concept is highly complex, combining 4 unproven technologies

Given the very early stage of some of these technologies, as well as TRL 5 being unlikely to be achieved by 2020, the paucity of reliable data and feasibility of even attempting a detailed engineering Case Study in Work Package 2 were also considerations in coming to our rejection recommendations.

## 6.2 Combinations recommended for progression

Provided that a combination did not have any major technical showstoppers, and a TRL of at least 5 could be achieved by 2020, then the technology combination was added to a list for debate at the end of the workshop. This debate included considerations on the range of capture categories covered, and the number of large (co-firing) vs. small-scale (dedicated biomass) combinations. As a result, two further combinations were not progressed:

- Dedicated biomass with carbonate looping **(10)** was not progressed, as it is not yet known if the calciner can be biomass-fired – i.e. co-firing percentages might be limited to <70%. Our recommendation is therefore to begin by exploring only the co-firing option (9)
- Co-firing chemical looping combustion **(13)** was not progressed, since coal gasification rates are slower than those for biomass, and unreacted char leads to carryover and loss of CO<sub>2</sub>. Also, chemical looping cannot be retrofitted to a pulverised coal plant – a CFB boiler is needed. Hence the dedicated biomass option (14) is preferred for progression instead

With feedback from the ETI Stage Gate Review meeting on 13<sup>th</sup> June 2011, this selection process left us with eight technologies combinations recommended for progression:

- (1)** Co-firing combustion, with post-combustion amine scrubbing
- (2)** Dedicated biomass combustion with post-combustion amine scrubbing
- (9)** Co-firing combustion, with post-combustion carbonate looping
- (11)** Co-firing oxy-combustion, with cryogenic O<sub>2</sub> separation
- (12)** Dedicated biomass oxy-combustion, with cryogenic O<sub>2</sub> separation
- (14)** Dedicated biomass chemical-looping-combustion using solid oxygen carriers
- (15)** Co-firing IGCC, with physical absorption
- (16)** Dedicated biomass IGCC, with physical absorption

An overall view of the combinations recommended for progression or rejected is given in Table 6.1. This shows that our recommendations cover all three main capture categories, and also give an equal split between large-scale co-firing combinations and small-scale dedicated biomass combinations.

**Table 6.1: Power-capture technology combinations proposed for progression/rejection**

		Post-combustion						Oxy-combustion			Pre-combustion					
		Solvent scrubbing, e.g. MEA, chilled ammonia	Low-temp solid sorbents, e.g. supported amines	Ionic liquids	Enzymes	Membrane separation of CO <sub>2</sub> from flue gas	High-temp solid sorbents, e.g. carbonate looping	Oxy-fuel boiler with cryogenic O <sub>2</sub> separation	Oxy-fuel boiler with membrane O <sub>2</sub> separation	Chemical-looping-combustion using solid oxygen carriers	IGCC with physical absorption e.g. Rectisol, Selexol	Membrane separation of H <sub>2</sub> from synthesis gases	Membrane production of syngas	Sorbent enhanced reforming using carbonate looping	ZECA concept	
<b>Coal IGCC gasification</b>	Direct cofiring	Not feasible						Not feasible			15	17	19	21	23	
	Conversion to 100% biomass	Not feasible						Not feasible			15	17	19	21	23	
<b>Pulverised coal combustion</b>	Direct cofiring	1	3	5	5a	7	9	11	11a	13	Not feasible					
	Conversion to 100% biomass	1	3	5	5a	7	9	11	11a	13						
<b>Dedicated biomass combustion</b>	Fixed grate	2	4	6	6a	8	10	12	12a	14						Not feasible
	Bubbling fluidised bed	2	4	6	6a	8	10	12	12a							
	Circulating fluidised bed	2	4	6	6a	8	10	12	12a							
<b>Dedicated biomass gasification</b>	Bubbling fluidised bed	Not feasible						Not feasible			14	16	18	20	22	24
	Circulating fluidised bed	Not feasible						Not feasible				16	18	20	22	24
	Dual fluidised bed	Not feasible						Not feasible				16	18	20	22	24
	Entrained flow	Not feasible						Not feasible				16	18	20	22	24

### 6.3 Quantitative supporting data

Further quantitative data is provided below for each of the technology combinations, to compare numerical factors such as the plant efficiency with capture, the CO<sub>2</sub> capture rate, and the estimated cost of avoided CO<sub>2</sub>. This data provides further evidence behind our choice of the shortlisted eight technology combinations.

Please note that this data is only taken from the literature values and information already gathered and reviewed in Work Packages 1.1 and 1.2. These are the best estimates available to us at this early stage of the TESBIC project – carrying out the detailed Case Studies and modelling in later Work Packages is required before more accurate figures can be given. Note that the error bounds on the estimates provided are especially large for the early stage technologies.

#### ***Common assumptions***

A number of common assumptions underpin this quantitative analysis:

- Biomass co-firing percentages are set at 20%, as the trend seen globally for new coal plants is towards this value, although higher percentages and 100% conversions could also be possible
- Large-scale plants are modelled at 600 MW<sub>e</sub> output, small-scale at 30 MW<sub>e</sub>
- Load factor of 85% assumed, i.e. 7446 hours of full-load operation per year
- Plant lifetime of 40 years, and a 10% discount rate
- Conversion emissions factor = 0.34 tCO<sub>2</sub>e/MWh for coal, 0.34 tCO<sub>2</sub>e/MWh for biomass
- Upstream emissions factor = 0.008 tCO<sub>2</sub>e/MWh for coal, 0.028 tCO<sub>2</sub>e/MWh for biomass
- Coal price of £8.5/MWh at all scales, biomass price of £18/MWh for small-scale applications (local energy crop prices), and £24/MWh for large-scale applications (reliant on more expensive imports)
- Operating costs are assumed to be 4% of capital costs for established technologies, 5% for those at pilot scale, and 6% for earlier stage technologies
- Cost error margins are assumed to be ±20% for established technologies, ±40% for those at pilot scale, and ±60% for earlier stage technologies, with a further ±5% for small-scale biomass systems

#### ***Plant efficiencies with capture***

Figure 6.1 shows that plant LHV efficiencies with capture are generally lowest for post-combustion capture systems, and highest for the pre-combustion capture systems. Plant efficiencies are lower for dedicated biomass systems than for co-firing systems, due to the smaller scales of the dedicated systems, lower biomass calorific values, reaction temperatures and CO<sub>2</sub> concentrations.

#### ***CO<sub>2</sub> capture rates***

As shown in Figure 6.1, CO<sub>2</sub> capture rates are generally expected to be around 90% for most technologies. Chemical Looping Combustion (combinations 13 and 14) is however a notable exception, with capture rates well above 95% expected. Ca looping also has the optional additional advantage of potentially decarbonising the cement industry by around 50 % by utilisation of the spent sorbent, which would add another 5 to 10 %-points to the net CO<sub>2</sub> capture rate.

Figure 6.1: Estimated plant LHV efficiencies with capture, and CO<sub>2</sub> capture rates, for each technology combination (error bars not shown)

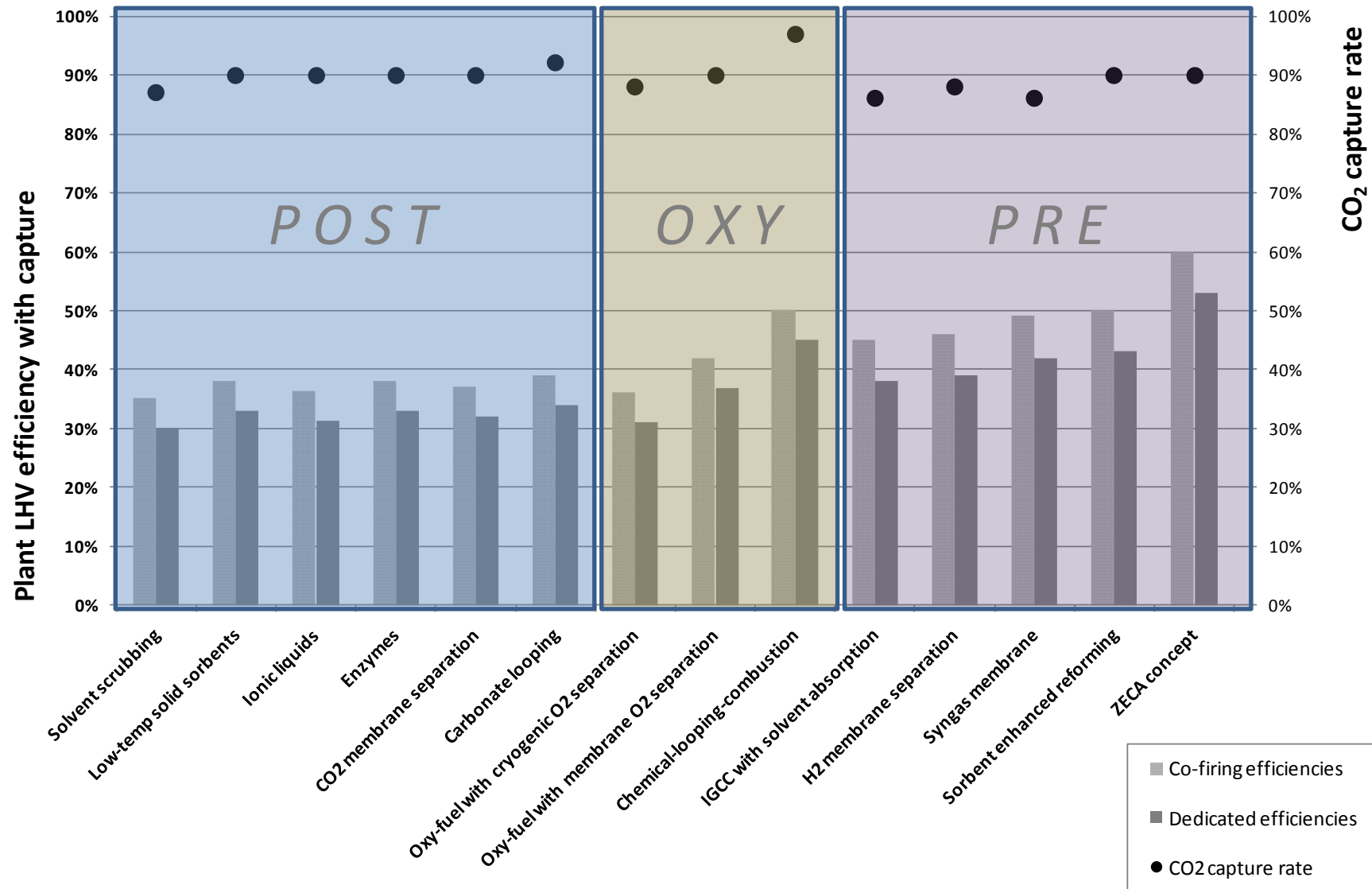
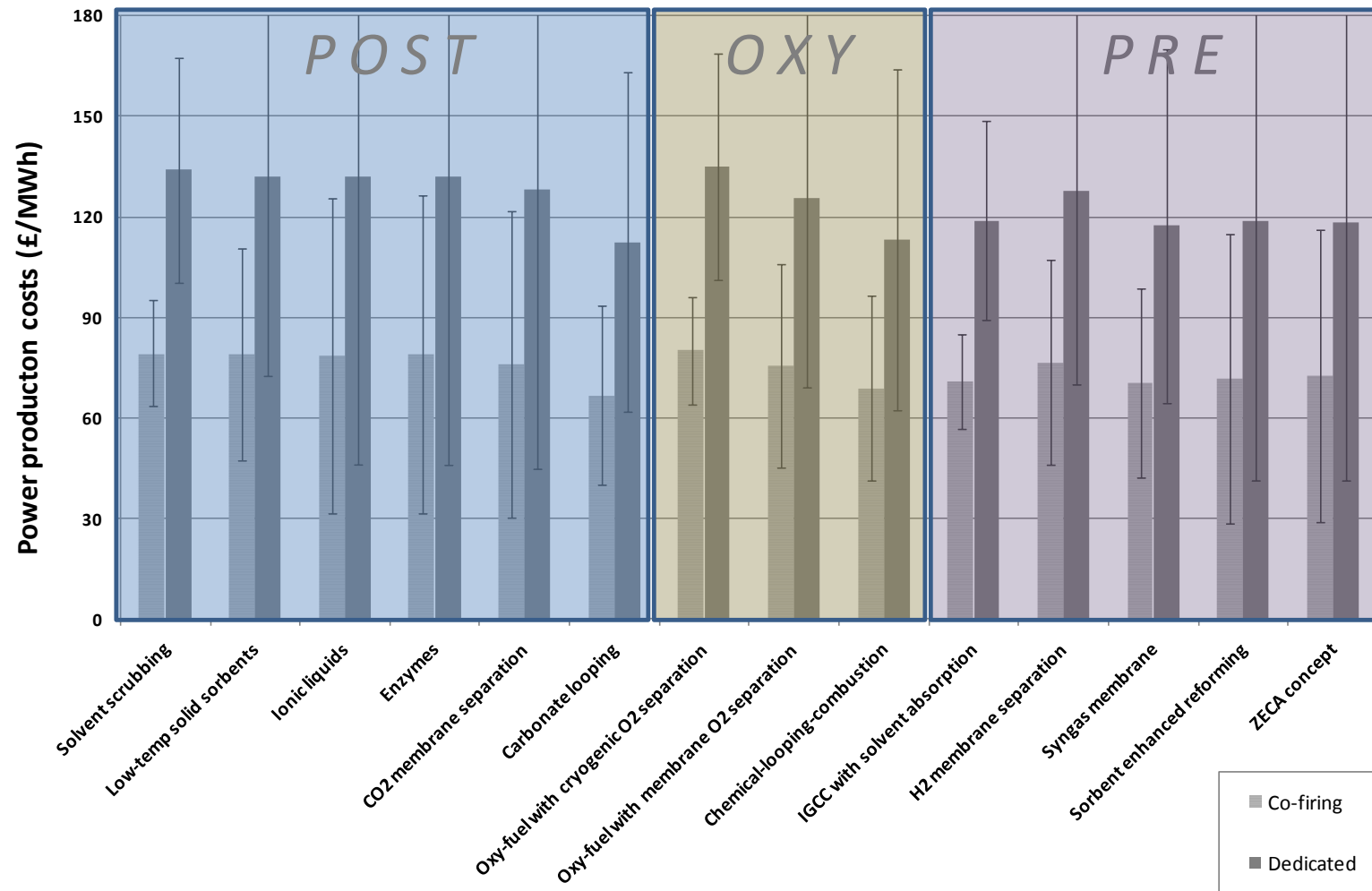

Figure 6.2: Estimated LCOE for each technology combination





### **Power production costs**

The levelised cost of electricity (LCOE) for a power plant with capture is defined as:

$$LCOE = \frac{\text{Annualised capex} + \text{Annual operating costs}}{\text{Annual power output}} + \frac{\text{Fuel price}}{\text{Efficiency}}$$

The LCOE for each technology combination with capture is shown in Figure 6.2. The ranges of LCOE are quite small, between 67-80 £/MWh for co-firing, and 110-135 £/MWh for dedicated biomass. This is because the higher efficiencies of the more novel technology combinations are usually offset by higher capital or operating costs.

Note that costs for early-stage technologies such as ionic liquids, enzymes, membrane systems, sorbent enhanced reforming and ZECA concepts are highly uncertain, and are likely to currently be much higher than the future costs estimated here for commercial scale plants.

### **Cost of avoided CO<sub>2</sub>**

The cost of avoided CO<sub>2</sub> is the additional expense incurred by saving CO<sub>2</sub> emissions compared to a chosen baseline plant. Estimates for the cost of avoided CO<sub>2</sub> for each technology combination were calculated by taking the difference in levelised cost of electricity (£/MWh<sub>e</sub>) between the chosen plant with capture and a baseline plant without capture, and then dividing by the difference in emissions factors (tCO<sub>2</sub>/MWh<sub>e</sub>) between the plants, as shown below:

$$\text{Cost of avoided CO}_2 = \frac{LCOE_{\text{with capture}} - LCOE_{\text{baseline without capture}}}{\text{Emissions factor}_{\text{baseline without capture}} - \text{Emissions factor}_{\text{with capture}}}$$

We have made the assumption that the baseline plant would be the most similar plant available without capture, i.e. still using the same amount of biomass (and coal), and using the same combustion boiler or gasifier technology. Therefore, for large-scale, co-firing applications:

- Post-combustion and oxy-combustion capture combinations are compared to a new pulverised coal combustion plant without capture (45% efficiency)
- For large-scale co-firing applications, pre-combustion capture combinations are compared to a new IGCC plant without capture (52% efficiency)

For small-scale, dedicated biomass applications:

- Post- and oxy-combustion capture combinations are compared to a new dedicated biomass CFB combustion plant without capture (40% efficiency)
- For small-scale dedicated biomass applications, pre-combustion capture combinations are compared to a new dedicated BIGCC plant without capture (45% efficiency)

Using this methodology, the cost of avoided CO<sub>2</sub> for each technology combination is shown in Figure 6.3. The lowest cost of avoided carbon is expected for post-combustion carbonate looping (9, 10), due to the low materials costs, low efficiency penalty, and repowering of system reducing additional capital costs. Other high efficiency technologies also have a relatively low cost of avoided carbon, such as IGCC (15, 16), and chemical looping combustion (13, 14).

An alternative methodology would be to compare every technology combination against only one baseline power plant – for example, a new pulverised coal combustion plant without capture (45% efficiency). These results (as shown in Figure 6.4) are not drastically different, except that the costs of avoided CO<sub>2</sub> for the dedicated biomass options have increased (due to the baseline technology now being at much larger scale), and the costs for the pre-combustion options have decreased slightly (due to the baseline technology now being less efficient than an IGCC without capture).

### ***Cost of CO<sub>2</sub> captured***

The cost of CO<sub>2</sub> captured is the total expense incurred by the plant with capture (not compared against any baseline). Estimates for the cost of CO<sub>2</sub> captured for each technology combination with capture were calculated by multiplying the levelised cost of electricity (£/MWh<sub>e</sub>) by the annual output (MWh<sub>e</sub>/yr), then dividing by the annual amount of CO<sub>2</sub> captured (tCO<sub>2</sub>/yr), as shown below:

$$\text{Cost of CO}_2 \text{ captured} = \frac{\text{LCOE}_{\text{with capture}} \times \text{Annual power output}}{\text{Annual CO}_2 \text{ captured}}$$

Using this methodology, the cost of CO<sub>2</sub> captured for each technology combination is shown in Figure 6.5. What is noticeable is that the high efficiency combinations have a high cost of CO<sub>2</sub> captured (e.g. ZECA concepts 23 and 24). This is because for the same annual power output, higher efficiencies mean less biomass input is required, and hence less CO<sub>2</sub> is produced and captured – i.e. those plants with the highest efficiencies (e.g. ZECA) capture the *least* amount of CO<sub>2</sub> annually. This reduction in MtCO<sub>2</sub>/yr captured outweighs the slight decrease in LCOE due to lower biomass annual costs. For this reason, the post-combustion capture combinations show the lowest costs, due to their low efficiency.

It is for the same set of reasons that the emissions factors of the low efficiency dedicated biomass plants are much lower (more negative) than those of the higher efficiency combinations. For example, dedicated biomass with amine scrubbing has an emissions factor of around -960gCO<sub>2</sub>e/kWh, whereas dedicated biomass ZECA might only have an emission factor of -570 gCO<sub>2</sub>e/kWh.

If the future carbon price (for sequestration) is high enough, then the primary revenue stream from a biomass CCS plant will be from the CO<sub>2</sub> captured, not from the power generated. In this case, then provided biomass prices are low, there is an incentive to use more biomass, capture more carbon, and not generate more power, i.e. low efficiencies are beneficial. If the CO<sub>2</sub> price outweighs the power prices and the biomass costs, then a biomass CCS plant stops being just a power plant, and is now primarily a CO<sub>2</sub> capture plant (the key metric becomes £/tCO<sub>2</sub> captured, not £/MWh generated).

Figure 6.3: Estimated cost of avoided CO<sub>2</sub>, for each technology combination, using a “similar plant without capture” baseline

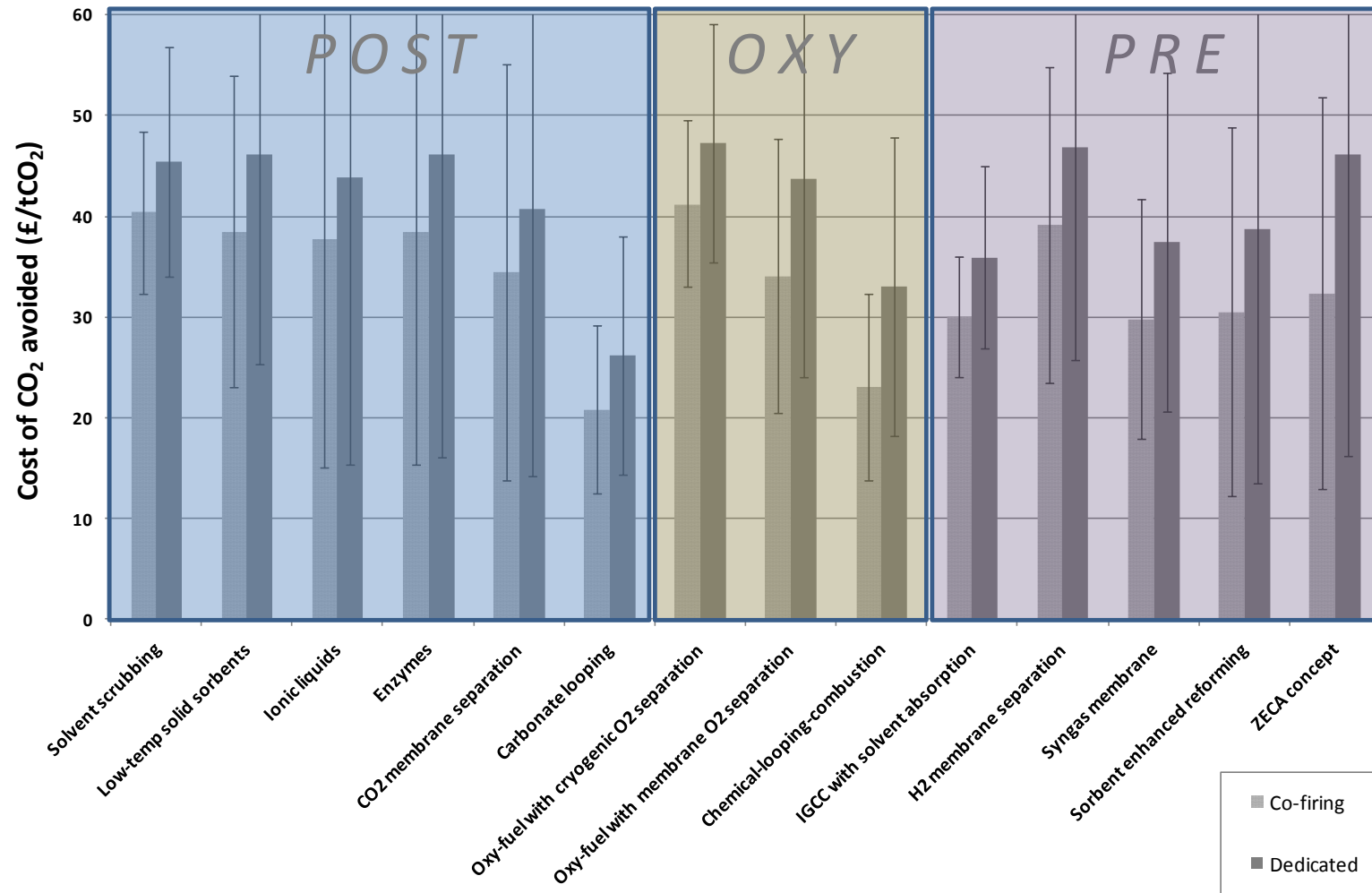

Figure 6.4: Estimated cost of avoided CO<sub>2</sub>, for each technology combination, using a “PCC plant without capture” fixed baseline

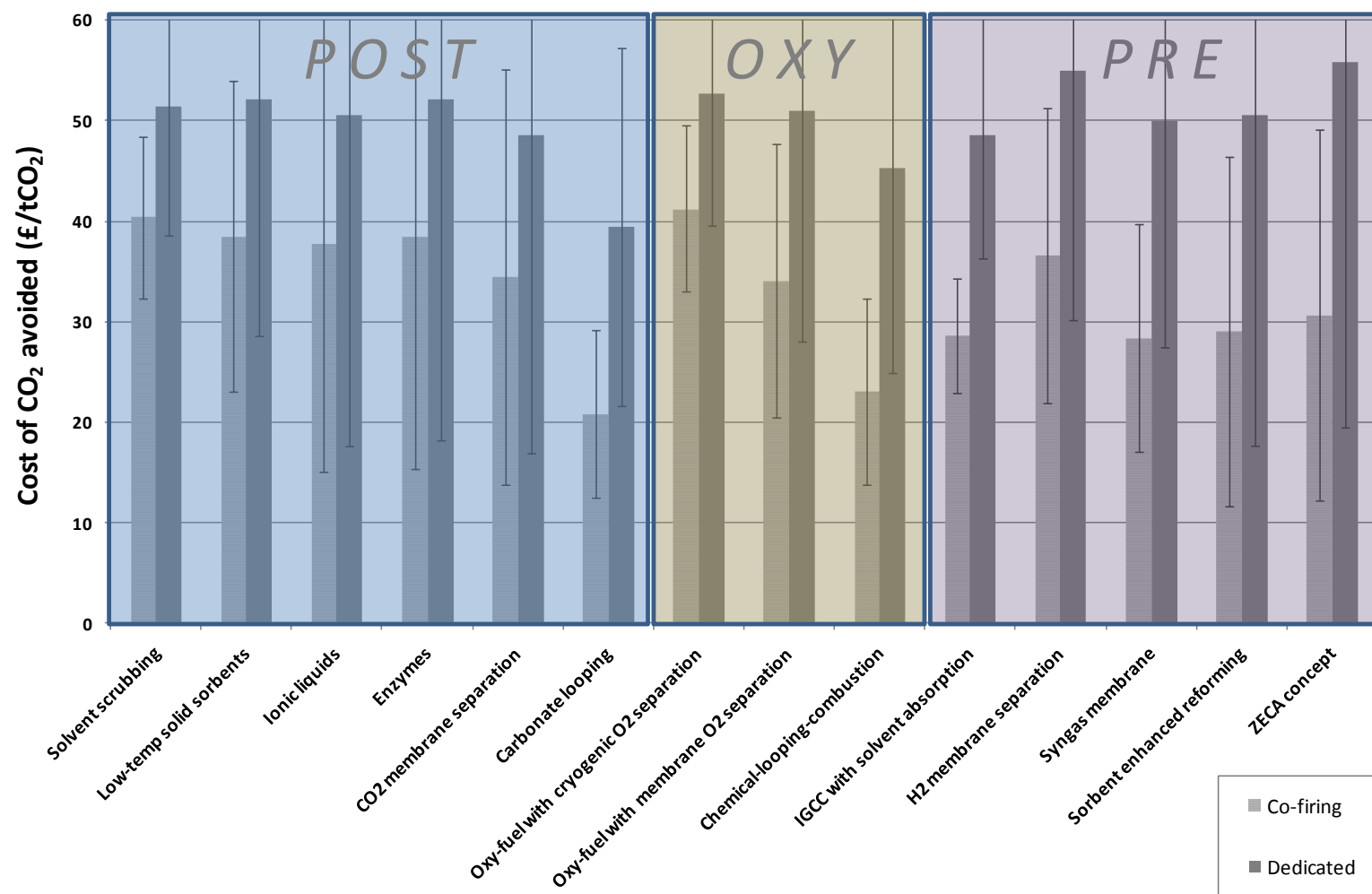
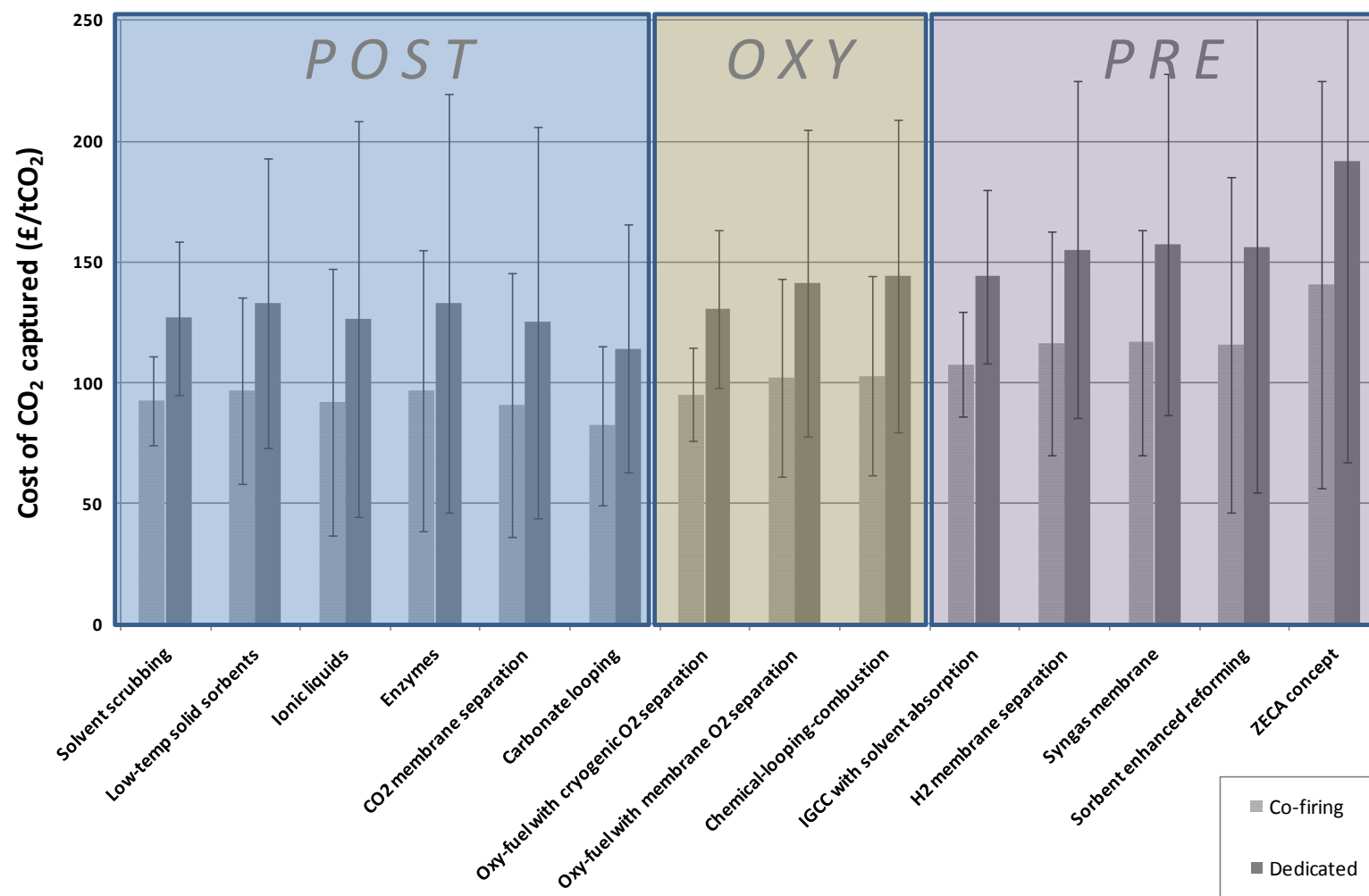

Figure 6.5: Estimated cost of CO<sub>2</sub> captured, for each technology combination



### ***Risk vs. reward***

Finally, as requested by ETI, an illustrative measure of risks vs. rewards is given in Figure 6.6. The higher the TRL, and the fewer the development issues and technical showstoppers, then the lower the risk – i.e. the technology combination will be found towards the left hand end of the x-axis. The lower the cost of avoided CO<sub>2</sub>, then the lower down the y-axis the technology combination will be found.

Other “reward” metrics could also be plotted on the y-axis instead of cost of CO<sub>2</sub> avoided, for example LCOE, cost of CO<sub>2</sub> captured, or efficiency with capture. However, cost of avoided CO<sub>2</sub> was felt to be an appropriate measure of the “rewards”, since it includes a variety of economic factors such as capture rate, plant efficiency and capital costs with capture in its calculation, and is also a useful indication of the carbon prices required to enable competitive viability with unabated fossil fuel or biomass generation.

Figure 6.6 gives a clear justification for why the shortlist of 8 technologies was chosen for progression. These 8 technologies have the lowest risk, i.e. are further left on the x-axis, and hence are most likely to be developed in time for 2050 mass-deployment. Whilst attractive in terms of potential deployment, they still cover a broad range of avoided CO<sub>2</sub> costs:

- The ‘benchmark’ near-term cases of co-firing with amine scrubbing (**1**) and oxy-fuel with cryogenic O<sub>2</sub> separation (**11**) have average costs of avoided CO<sub>2</sub>
- The corresponding dedicated biomass systems (combinations **2** and **12**) are more expensive, and at a slightly earlier stage of development, but there are not expected to be major technical differences to the co-firing cases
- Both co-firing (**15**) and dedicated biomass (**16**) IGCC with physical absorption are cheaper than the options above, mainly due to their higher efficiencies. However, (**16**) has only been considered theoretically so far, and there is not a clear development pathway since the current BIGCC plants without capture are not well suited to adding capture. There are, however, no major technical showstoppers, and knowledge spill-over from (**15**) and biofuels applications could accelerate (**16**)’s development. Of the dedicated biomass gasification combinations, (**16**) is still a clear winner over (**18**), (**20**), (**22**) & (**24**), both in terms of risk and reward.
- The more technically risky options of dedicated biomass Chemical Looping Combustion (**14**) and co-firing with post-combustion carbonate looping (**9**) show low costs of avoided CO<sub>2</sub>. (**9**) also has the potential benefit of cement industry decarbonisation at low cost. (**14**) could have even higher efficiencies (above 50%) via process integration options with gas turbines or H<sub>2</sub> production

Note that in order to keep the figure readable, the cost of avoided CO<sub>2</sub> y-axis error bars have been omitted: these error bars would be fairly small on the left-hand side, but much larger on the right for the more novel technologies.

Figure 6.6: Estimated cost of avoided CO<sub>2</sub> vs. technical issues to overcome, for each technology combination (error bars not shown)

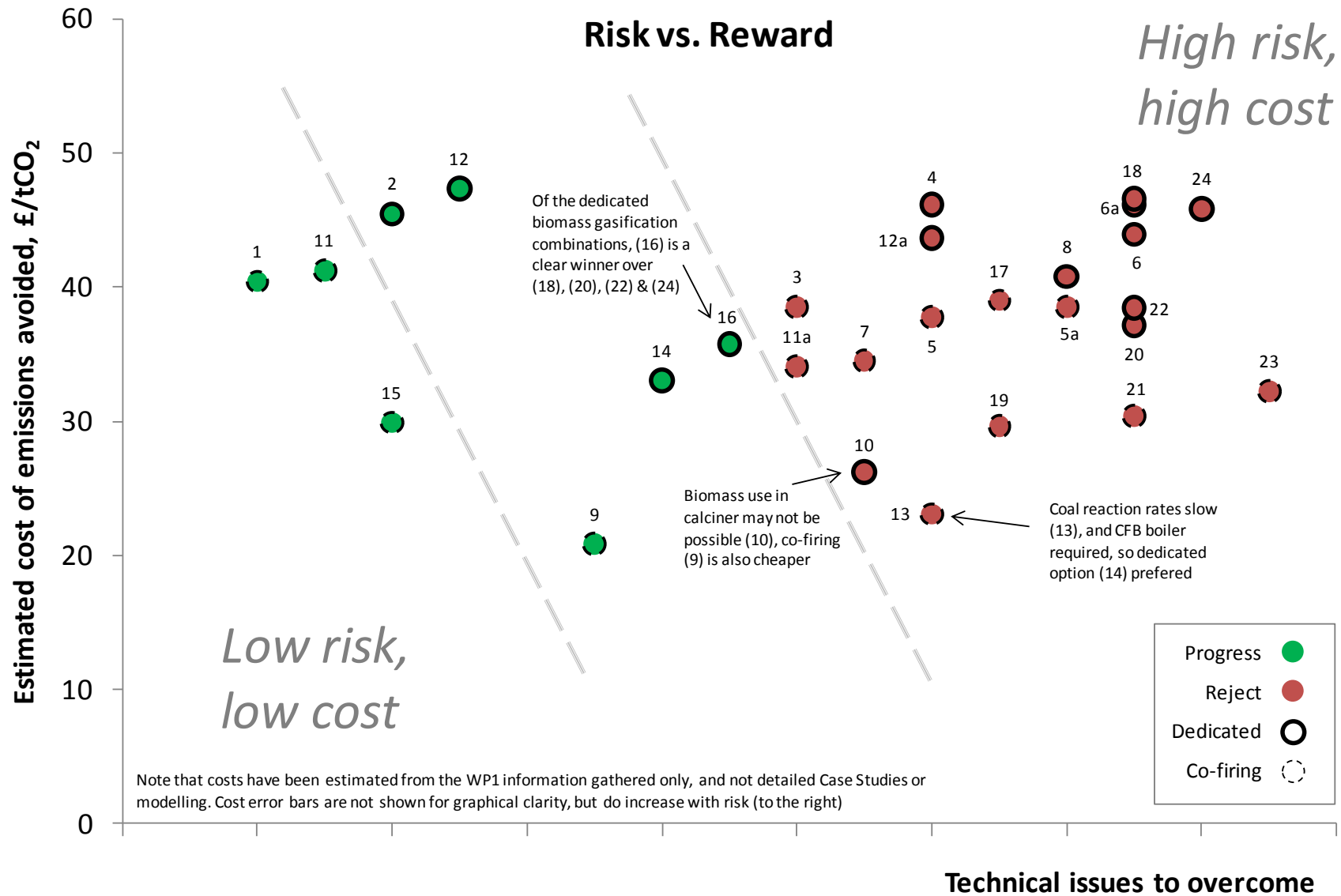

#### 6.4 Suitability for small-scale power applications

As part of the technology recommendations, at least one combination had to be suitable for small-scale power applications (approximately 10 - 30 MW<sub>e</sub>). As mentioned above, this is because ETI wish to understand the flexibility that a plant of this scale could provide in a future energy systems, with possible CO<sub>2</sub>, H<sub>2</sub> or syngas infrastructure configurations, and the ability to source all of the plant's required feedstock locally, without necessarily having to rely on more expensive imports (as is generally the case for larger plants >100 MW<sub>e</sub>).

Therefore, we have provided a discussion regarding which of the technologies we are recommending is most suitable for small scales. Given our eight recommended technologies, only the four dedicated biomass technologies are suitable for small-scale power applications, since the co-firing combinations using coal conversion technologies will generally be much larger scale. These four dedicated biomass combinations are: Amine scrubbing (**2**), Oxy-fuel (**12**), CLC (**14**) and BIGCC (**16**). Examining the relative benefits and risk of these technologies in more detail:

- Amine scrubbing (**2**) and oxy-fuel (**12**) will have low efficiencies at around 30% with capture, and relatively high avoided costs (£40-50/tCO<sub>2</sub>)
- BIGCC (**16**) has high efficiencies at around 38% with capture, but has high capital costs, and hence avoided carbon costs are still £35-40/tCO<sub>2</sub>. However, there may be interesting options for integration with a future syngas infrastructure, or H<sub>2</sub> buffer storage
- CLC (**14**) also has high efficiencies at around 39% with capture, but lower costs (£25-30/tCO<sub>2</sub>). There are also several innovative aspects, such as the ability to use pressurised hot gases in a gas turbine to generate extra power, or alternatively, co-produce H<sub>2</sub> for fuel cells or H<sub>2</sub> transport infrastructure – both would significant raise the plant efficiency

Therefore, CLC would appear to be the technology combination most suitable for small-scale dedicated biomass CCS, followed by BIGCC, with Oxy-fuel or Amine scrubbing options still suitable, but less attractive.

#### 6.5 Summary matrix

The summary matrix given below in Table 6.2 compares the key assessment criteria for each of the shortlisted combinations recommended for progression.



Table 6.2: Summary matrix comparing key criteria

Criteria	(1) Co-firing amine scrubbing	(2) Dedicated biomass with amine scrubbing	(9) Co-firing carbonate looping	(11) Co-firing oxy-fuel	(12) Dedicated biomass oxy-fuel	(14) Dedicated biomass chemical looping	(15) Co-firing IGCC	(16) Dedicated biomass BIGCC
<b>Current TRL</b>	6 to 7	4	4 to 5	6	5	4	5 to 6	4
<b>Likely TRL in 2020</b>	7 to 8	6 to 7	5 to 6	7	6	5 to 6	7	5 to 6
<b>Key technical issues</b>	Scale-up, amine degradation, potential losses to environment	Scale-up, amine degradation, potential losses to environment	Calciner firing, degradation, large purge of CaO	Corrosion, O <sub>2</sub> energy costs, slow response	Corrosion, O <sub>2</sub> energy costs, slow response	Loss in activity, reaction rates, dual bed operation	Complex operation, slow response, tar cleaning, retrofit unattractive	Complex operation, slow response, tar cleaning, retrofit unattractive
<b>Suitability for small scale</b>	Low	High	Low	Low	High	High	Low	High
<b>Plant efficiency with capture</b>	OK	Low	Good	OK Some gains with O <sub>2</sub> membrane	Low Some gains with O <sub>2</sub> membrane	Good High if at pressure, or H <sub>2</sub> for fuel cells	High, Very High with new gas turbines	Good, High with new gas turbines
<b>Capital costs with capture</b>	OK	Expensive	Low cost, although repowering requires capex	OK ASU costs could fall with O <sub>2</sub> membranes	Expensive ASU costs could fall with O <sub>2</sub> membranes	Low cost	OK, could fall with new gas turbines	Expensive, could fall with new gas turbines
<b>UK deployment potential</b>	Immediate capture retrofit opportunities, long-term doubtful	Numerous capture retrofit opportunities by ~2015, high long-term potential	Immediate capture retrofit opportunities, cement integration	Near-term retrofit opportunities, long-term doubtful	Numerous capture retrofit opportunities by ~2015, high long-term potential	Likely first demos in Europe, UK in ~2020. High long-term potential	No current UK plants, several demos by 2020, could co-fire. Long-term doubt	No current UK plants, demo unlikely by 2020. High long-term potential